

PRODUCT CATALOG



Husky
A BREED APART





Husky

GENERAL FUELING PRODUCTS

Table of Contents

NOZZLES

Conventional 1-0

Husky 1A

- Metal Hand Guard 1-1
- Polymer Hand Guard..... 1-2

Safe-T-Squeeze 1-3

Husky X

- Standard 1-4
- BSPP 1-5
- Cold Weather 1-6
- Double Poppet 1-7
- Rebuilt 1-8
- Sightglass 1-9

Husky XS

- Standard 1-10
- BSPP 1-11
- Cold Weather 1-12
- Double Poppet 1-13
- MFM 1-14
- Rebuilt 1-15
- Sightglass 1-16

Farm and Commercial 2-0

Husky 1GS

- Aluminum Hand Guard..... 2-1
- Polymer Hand Guard..... 2-2
- Rebuilt 2-3

Husky XFS 2-4

Diesel Exhaust Fluid..... 3-0

- DEF Stainless Steel 3-1
- DEF Polymer 3-2

Truck and High Volume..... 4-0

- 1690 4-1
- 1690/1691 Cold Weather 4-2

Husky 1HS

- Aluminum Hand Guard..... 4-3
- Polymer Hand Guard..... 4-4

Husky VIII

- Standard 4-5
- BSPP 4-6
- Cold Weather 4-7

Husky VIIIS

- Standard 4-8
- BSPP 4-9
- Cold Weather 4-10

Vapor Recovery 5-0

Husky V

- Standard 5-1
- EVR LX 5-2

Husky V3 5-3

Husky V34

- Standard 5-4
- Coax Nozzle 5-5
- Double Poppet 5-6
- ORVR Vacuum Assist 5-7

Husky V34i

- Standard 5-8
- Double Poppet 5-9
- Double Poppet / Cold Weather..... 5-10

Husky V34iA

- Double Poppet 5-11

Husky 34iS

- Standard 5-12
- Double Poppet 5-13

Husky V34iSA

- Double Poppet 5-14

Husky VLX 5-15

Ethanol Fueling 6-0

- X E85 6-1
- X E85 Cold Weather..... 6-2
- XS E85 6-3
- XS E85 Cold Weather..... 6-4

CNG Nozzles 7-0

- CNG 7-1

Whiskey Nozzles 8-0

- WN 8-1
- XWN 8-2



Husky

GENERAL FUELING PRODUCTS

Table of Contents

ACCESSORIES

Swivels	9-0
Standard	9-1
Inline	9-2
Farm & Commercial	
Standard	9-3
Truck & High Volume	9-4
Vapor Recovery	9-5
Truck & High Volume	
Diesel	9-6
High Volume	9-7
Diesel Exhaust Fluid	
Model 7269	9-8
Model 7275	9-8
Model 7282	9-8
Model 7467	9-8
Ethanol Fueling	
E85 Swivel	9-9
Safe-T-Breaks	10-0
Conventional	
Standard	10-1
MagBreak®	10-2
Farm & Commercial	
Standard	10-3
Truck & High Volume	10-4
Diesel Exhaust Fluid	
Husky DEF	10-5
Truck and High Volume	
Truck & High Volume	10-6
Vapor Recovery	
Balance Vapor	10-7
Vacuum Assist	10-8
Ethanol Fueling	
E85 STB	10-9
Swivel / Safe-T-Break Combos . . .	11-0
Conventional	11-1
Truck & High Volume	11-2
Guards	12-0
Nozzle and STB Guards	12-1
Nozzle POPD™ Guards	12-2

Spouts	13-0
X and XS Spout Assembly	13-1
Safe-T-Squeeze Spout Assembly	13-2
1GS Spout Assembly	13-3
DEF Spout Assembly	13-4
VIII and VIIIIS Spout Assembly	13-5
V, V3 and V34 Spout Assembly	13-6
E85 Spout Assembly	13-7

Pressure/Vacuum Vents	14-0
Model 8060	14-1
Model 4620	14-2
Model 4885	14-2
Model 5885	14-2

Test & Maintenance	15-0
Nozzle Service Kit	15-1

Flo-Equalizer™	16-0
Conventional Systems	
Husky 4490	16-1
Recovery Systems	
Husky 5827	16-1
Husky 5837	16-1

DEF Adaptors	17-0
7214	17-1
7285	17-1
7356	17-1
8413	17-1

HOSES

Curb Hoses	18-0
Curb Hoses	
EagleFlex® Hardwall	18-1
EagleFlex® Softwall	18-2
EagleFlex® Wirebraid	18-3
Farm Fueling Hoses	
Premier	18-4
Whip Hoses	18-5

EZ-Connect	19-0
EZ-Connect	19-1



Husky

GENERAL FUELING PRODUCTS

Conventional Nozzles

1A Nozzles



Automatic shut-off nozzle for full-service and self-service stations.

- 1A nozzle shuts off when the gas tank is full.
- Aluminum reinforced spout bushing keeps the spout tip round and acts as a captive fastener to prevent tip-end sensor damage.
- Nozzle is equipped with a unique Flo-Stop™ device that shuts off the nozzle if it falls from the fill tank or raises above the horizontal.
- *StreamShaper™* reduces turbulence for straighter fuel flow and less splash back spillage.
- Comes standard with smooth full grip guard.



New Unleaded Nozzles w/ NPTF

MODEL NO.	DESCRIPTION	SHIPPING WEIGHT LBS (KG)
696104	with Three Notch Hold Open Clip	3.3 (1.4)
696108	without Hold Open Clip	3.3 (1.4)
696159	with Three Notch Hold Open Clip, Full Grip Guard and Reducer Bushing	3.3 (1.4)
696164	with Three Notch Hold Open Clip and Waffle Splash Guard	3.3 (1.4)
696172	with Three Notch Hold Open Clip, Waffle Splash Guard and Reducer Bushing	3.3 (1.4)

New Unleaded Nozzles w/ BSPP Threads

MODEL NO.	DESCRIPTION	SHIPPING WEIGHT LBS (KG)
696116	with Three Notch Hold Open Clip	3.4 (1.5)
696120	without Hold Open Clip	3.4 (1.5)

New Light Duty Diesel Nozzles w/ NPTF Threads

MODEL NO.	DESCRIPTION	SHIPPING WEIGHT LBS (KG)
696103	with Three Notch Hold Open Clip	3.4 (1.5)
696107	without Hold Open Clip	3.4 (1.5)
696161	with Three Notch Hold Open Clip and Reducer Bushing	3.4 (1.5)
696163	with Three Notch Hold Open Clip and Waffle Splash Guard	3.4 (1.5)
696173	with Three Notch Hold Open Clip, Waffle Splash Guard and Reducer Bushing	3.4 (1.5)

New Light Duty Diesel Nozzles w/ BSPP Threads

MODEL NO.	DESCRIPTION	SHIPPING WEIGHT LBS (KG)
696115	with Three Notch Hold Open Clip	3.4 (1.5)
696119	without Hold Open Clip	3.4 (1.5)

Construction

Body	One piece die cast aluminum
Seals	Fluorocarbon
Packing	Double o-ring seal protected by fiber reinforced Teflon
Lever	One piece contoured steel
Inlet	1" / 25.4 mm NPTF & BSPP

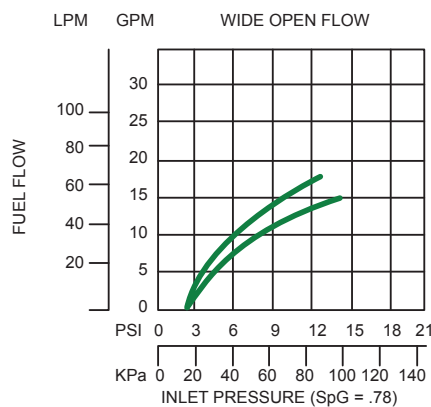



Automatic shut-off nozzle for full-service and self-service stations.

Dimensions and System Options

Safe-T-Breaks®

MODEL NO.	DESCRIPTION
2276	1" F x 1" F NPTF Reconnectable Safe-T-Break®
5812	1" F x 1" F NPTF Non-Reconnectable Safe-T-Break®
6301	1" F x 1" F NPTF Non-Reconnectable PCC Safe-T-Break®
5231	1" F x 1" F NPTF Low Pull Reconnectable Safe-T-Break®
3076	1" F x 1" F BSPP Reconnectable Safe-T-Break®
3076A	1" F x 1" F BSPP Reconnectable Safe-T-Break® - Atex
6914	1" F x 1" F BSPP Non-Reconnectable Safe-T-Break®

Swivels

Model No.	Description
0087	1" M x 1" F NPTF Multi-Plane Swivel
0087W	1" M x 1" F NPTF Multi-Plane Swivel with Warm Weather Seals
4860	1" M x 1" F NPTF Multi-Plane High Flow Swivel
0095	1" M x 1" F NPTF 70° Pump Swivel
3395	1" M x 1" F NPTF Multi-Plane Restricted Swivel
0352	1" M x ¾" F NPTF Multi-Plane Swivel
0356	1" M x ¾" F NPTF Multi-Plane Swivel Anodized Black
3306	1" M x 1" F BSPP Multi-Plane Swivel
3306W	1" M x 1" F BSPP Multi-Plane Swivel with Warm Weather Seals
6949	1" M x 1" F BSPP Multi-Plane High Flow Swivel

Swivel/Safe-T-Break® Combos

MODEL NO.	DESCRIPTION
5969	1" M NPTF Multi-Plane Swivel connected to 1" F NPTF Reconnectable Safe-T-Break®
8015	1" M BSPP Multi-Plane Swivel connected to 1" F BSPP Reconnectable Safe-T-Break®

Spouts

MODEL NO.	DESCRIPTION
1473	Unleaded Spout without Flo-Stop™
1471	Light Duty Diesel Spout without Flo-Stop™

Pressure/Vacuum Vents

MODEL NO.	DESCRIPTION
4620	2" Slip-On Pressure Vacuum Vent
4885	2" Thread-On Pressure Vacuum Vent - NPTF
5885	2" Thread-On Pressure Vacuum Vent with internal screen - NPTF

Accessories, Testing and Maintenance

MODEL NO.	DESCRIPTION
7089	Nozzle Service Kit
3593	Hold Open Clip Kit
0397	Unleaded Spout Gauge
0385	1" M x ¾" F Reducer Bushing

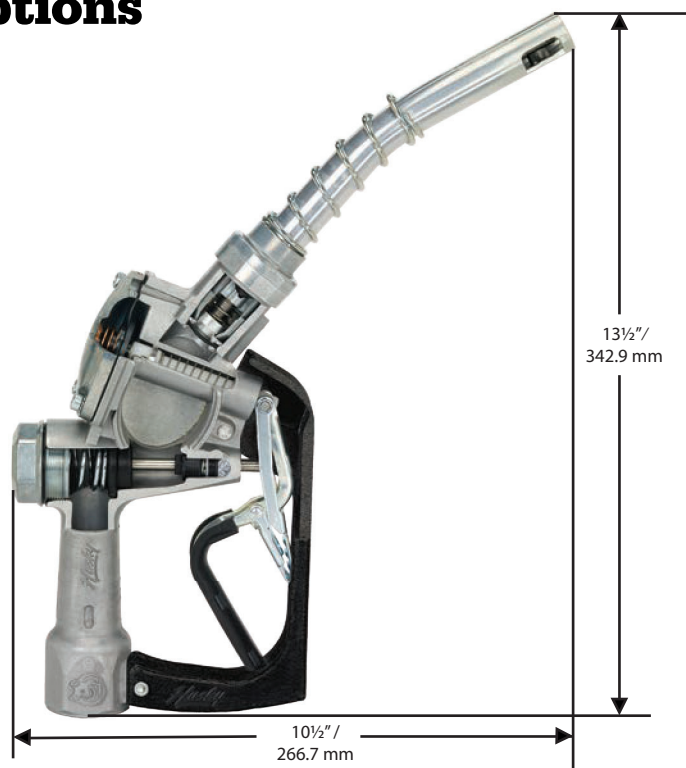

Guards

MODEL NO.	DESCRIPTION
0554	Full Grip Guard
6655	POPD™ S Full Grip Guard
8183	POPD™ H Full Grip Guard
1804	Full Grip Reguard
7210	POPD™ S Full Grip Reguard
8190	POPD™ H Full Grip Reguard
0226	Mate Nozzle Guard
8169	POPD™ S Mate Nozzle Guard
8170	POPD™ H Mate Nozzle Guard
8179	POPD™ EZS Nozzle Guard
8180	POPD™ EZH Nozzle Guard
1808	Waffle Splash Guard
0099	Protection Package
1811	Reguard Protection Package
6628	POPD™ S Clear Cover
7999	POPD™ H Clear Cover
5494	Lever Guard
3376	Mate Handle Guard
7376	POPD™ Mate Handle Guard



1A Nozzles



Automatic shut-off nozzle for full-service and self-service stations.

- 1A nozzle shuts off when the gas tank is full.
- Equipped with a unique Flo-Stop™ device that shuts off the nozzle if it falls from the fill tank or raises above the horizontal.
- Aluminum reinforced spout bushing keeps spout tip round and acts as a captive fastener to prevent tip-end sensor damage.
- *StreamShaper™* reduces turbulence for straighter fuel flow and less splash back spillage.
- Comes standard with smooth full grip guard.

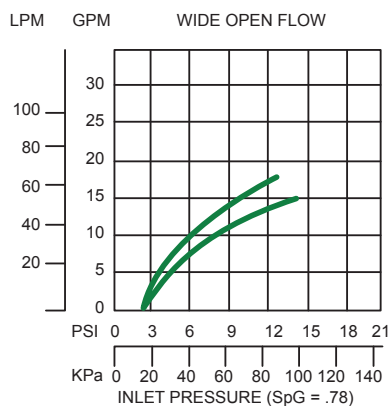
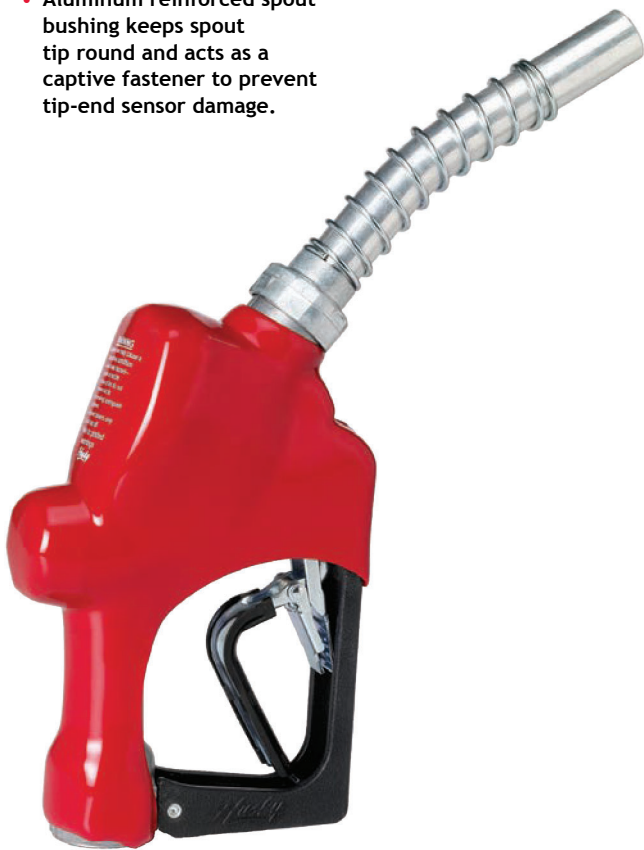

New Unleaded Nozzles with NPTF Threads

MODEL NO.	DESCRIPTION	SHIPPING WEIGHT LBS (KG)
209804	with Three Notch Hold Open Clip	3.3 (1.4)
209808	without Hold Open Clip	3.3 (1.4)
209859	with Three Notch Hold Open Clip, Full Grip Guard and Reducer Bushing	3.3 (1.4)
209864	with Three Notch Hold Open Clip and Waffle Splash Guard	3.3 (1.4)
209872	with Three Notch Hold Open Clip, Waffle Splash Guard and Reducer Bushing	3.3 (1.4)

New Unleaded Nozzles with BSPP Threads

MODEL NO.	DESCRIPTION	SHIPPING WEIGHT LBS (KG)
209816	with Three Notch Hold Open Clip	3.4 (1.5)
209820	without Hold Open Clip	3.4 (1.5)

New Light Duty Diesel Nozzles w/ NPTF Threads

MODEL NO.	DESCRIPTION	SHIPPING WEIGHT LBS (KG)
209803	with Three Notch Hold Open Clip	3.4 (1.5)
209807	without Hold Open Clip	3.4 (1.5)
209861	with Three Notch Hold Open Clip and Reducer Bushing	3.4 (1.5)
209863	with Three Notch Hold Open Clip and Waffle Splash Guard	3.4 (1.5)
209873	with Three Notch Hold Open Clip, Waffle Splash Guard and Reducer Bushing	3.4 (1.5)

New Light Duty Diesel Nozzles w/ BSPP Threads

MODEL NO.	DESCRIPTION	SHIPPING WEIGHT LBS (KG)
209815	with Three Notch Hold Open Clip	3.4 (1.5)

Rebuilt Unleaded Nozzles

MODEL NO.	DESCRIPTION	SHIPPING WEIGHT LBS (KG)
074704	with Three Notch Hold Open Clip and Full Grip Guard	3.5 (1.6)
074708	without Hold Open Clip with Full Grip Guard	3.5 (1.6)
074759	with Three Notch Hold Open Clip, Full Grip Guard, and 0385 Reducer Bushing	3.5 (1.6)
074764	with Three Notch Hold Open Clip, Full Grip Guard, and 1808 Waffle Splash Guard	3.3 (1.4)
074772	with Three Notch Hold Open Clip, Full Grip Guard, 1808 Waffle Splash Guard, and 0385 Reducer Bushing	3.3 (1.4)

Rebuilt Light Duty Diesel Nozzles

MODEL NO.	DESCRIPTION	SHIPPING WEIGHT LBS (KG)
074703	with Three Notch Hold Open Clip and Full Grip Guard	3.6 (1.7)
074707	without Hold Open Clip with Full Grip Guard	3.6 (1.7)
074761	with Three Notch Hold Open Clip, Full Grip Guard, and 0385 Reducer Bushing	3.6 (1.7)
074763	with Three Notch Hold Open Clip, Full Grip Guard, and 1808 Waffle Splash Guard	3.0 (1.3)
074773	with Three Notch Hold Open Clip, Full Grip Guard, 1808 Waffle Splash Guard and 0385 Reducer Bushing	3.0 (1.3)

Construction

Body	Die cast aluminum body with black hand guard
Seals	Fluorocarbon
Packing	Double o-ring seal protected by fiber reinforced Teflon
Lever	One piece contoured steel with hard plastic cover
Inlet	1" / 25.4 mm NPTF & BSPP



**Husky**

GENERAL FUELING PRODUCTS

1A Nozzles

Automatic shut-off nozzle for full-service and self-service stations.

Dimensions and System Options

Safe-T-Breaks®

MODEL NO.	DESCRIPTION
2276	1" F x 1" F NPTF Reconnectable Safe-T-Break®
5812	1" F x 1" F NPTF Non-Reconnectable Safe-T-Break®
6301	1" F x 1" F NPTF Non-Reconnectable PCC Safe-T-Break®
5231	1" F x 1" F NPTF Low Pull Reconnectable
3076	1" F x 1" F BSPP Reconnectable Safe-T-Break®
3076A	1" F x 1" F BSPP Reconnectable Safe-T-Break® - Atex
6914	1" F x 1" F BSPP Non-Reconnectable Safe-T-Break®

Swivels

MODEL NO.	DESCRIPTION
0087	1" M x 1" F NPTF Multi-Plane Swivel
0087W	1" M x 1" F NPTF Multi-Plane Swivel w/ Warm Weather Seals
4860	1" M x 1" F NPTF Multi-Plane High Flow Swivel
0095	1" M x 1" F NPTF 70° Pump Swivel
3395	1" M x 1" F NPTF Multi-Plane Restricted Swivel
0352	1" M x 3/4" F NPTF Multi-Plane Swivel
0356	1" M x 3/4" F NPTF Multi-Plane Swivel Anodized Black
3306	1" M x 1" F BSPP Multi-Plane Swivel
3306W	1" M x 1" F BSPP Multi-Plane Swivel w/ Warm Weather Seals
6949	1" M x 1" F BSPP Multi-Plane High Flow Swivel

Swivel/Safe-T-Break® Combos

MODEL NO.	DESCRIPTION
5969	1" M NPTF Multi-Plane Swivel and 1" F NPTF Reconnectable Safe-T-Break®
8015	1" M BSPP Multi-Plane Swivel and 1" F BSPP Reconnectable Safe-T-Break®

Spouts

MODEL NO.	DESCRIPTION
1473	Unleaded Spout w/o Flo-Stop™
1471	Light Duty Diesel Spout w/o Flo-Stop™

Pressure/Vacuum Vents

MODEL NO.	DESCRIPTION
4620	2" Slip-On Pressure Vacuum Vent
4885	2" Thread-On Pressure Vacuum Vent - NPTF
5885	2" Thread-On Pressure Vacuum Vent with internal screen - NPTF

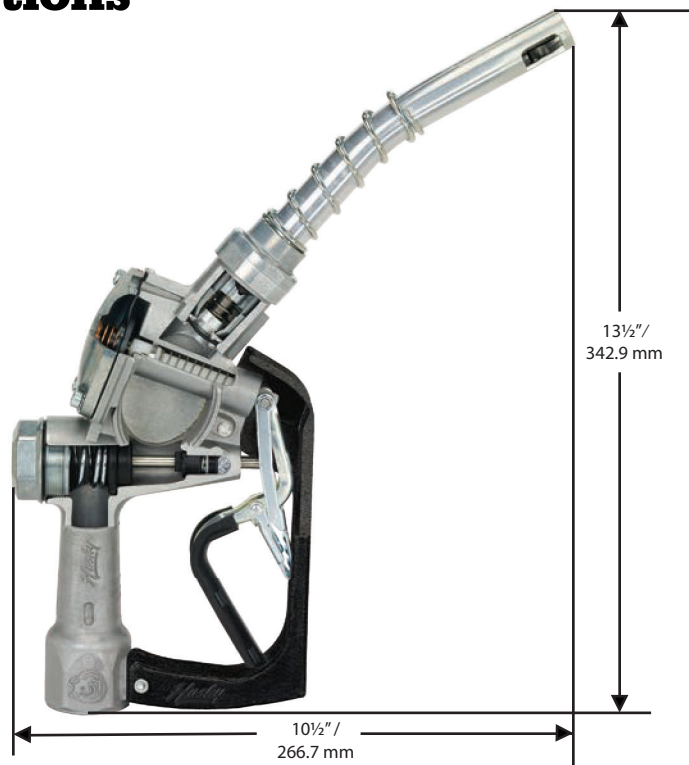

Guards

MODEL NO.	DESCRIPTION
0554	Full Grip Guard
6655	POPD™ Full Grip Guard
8183	POPD™ H Full Grip Guard
1804	Full Grip Reguard
7210	POPD™ Full Grip Nozzle Reguard
8190	POPD™ H Full Grip Reguard
0226	Mate Nozzle Guard
8169	POPD™ S Mate Nozzle Guard
8170	POPD™ H Mate Nozzle Guard
8179	POPD™ EZS Nozzle Guard
8180	POPD™ EZH Nozzle Guard
1808	Waffle Splash Guard
0099	Protection Package
1811	Reguard Protection Package
6628	POPD™ Clear Cover
7999	POPD™ H Clear Cover
5494	Lever Guard
7295	Mate Handle Guard



MADE IN THE U.S.A.



Safe-T-Squeeze Nozzles



Husky

GENERAL FUELING PRODUCTS

Automatic shut off nozzle for full-service and self-service stations.

- Unique internal interlock device that shuts off the fuel flow before the spout is out of the tank.
- Aluminum casting with high impact polymer hand guard provides a lightweight, easier to handle conventional nozzle.
- 2-piece lever is easier to use.
 - wider and smoother
 - requires ½ the force to open nozzle
 - protective cover is riveted so will not slide
- Aluminum reinforced spout bushing keeps spout tip round and acts as a captive fastener to prevent tip-end sensor damage.
- Drip Less spout reduces/eliminates drips from spout.
- *StreamShaper™* reduces turbulence for straighter fuel flow and less splash back spillage.
- Lightest insertion “force” of any bellow operated nozzle.
- Easy and inexpensive to maintain due to the one-piece bellow.
- Bellow face seal has “vents” to prevent splash back spillage.
- Comes standard with smooth full grip guard.



New Unleaded Nozzles

MODEL NO.	DESCRIPTION	SHIPPING WEIGHT LBS (KG)
602504	with Two Notch Hold Open Clip	3.6 (1.6)
602582	with Two Notch Hold Open Clip and Drip Less Spout	3.6 (1.6)

Construction

Body	One piece die cast aluminum
Seals	Fluorocarbon
Packing	Double o-ring seal protected by fiber reinforced Teflon
Lever	Two piece steel with high impact polymer cover
Inlet	¾" / 19.1 mm NPTF

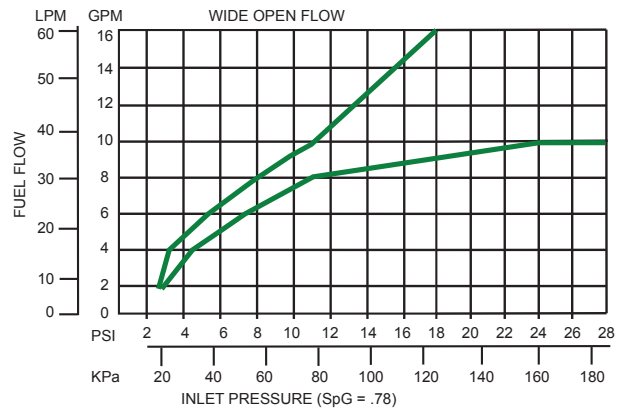

**Husky**

GENERAL FUELING PRODUCTS

Safe-T-Squeeze Nozzles

Automatic shut off nozzle for full-service and self-service stations.

Dimensions and System Options

Safe-T-Breaks®

MODEL NO.	DESCRIPTION
2273	¾" F x ¾" F NPTF Non-Reconnectable Safe-T-Break®
3360	¾" F x ¾" F NPTF Reconnectable Safe-T-Break®
5230	¾" F x ¾" F NPTF Low Pull Reconnectable
6130	¾" F x ¾" F NPTF Non-Reconnectable PCC Safe-T-Break®
227374	¾" F x ¾" F NPTF Non-Reconnectable Safe-T-Break® w/ ¾" M x ¾" M Whip Hose
227375	¾" F x ¾" F NPTF Non-Reconnectable Safe-T-Break® w/ ¾" M x ¾" M Whip Hose w/ Swivel Nut
336074	¾" F x ¾" F NPTF Reconnectable Safe-T-Break® w/ ¾" M x ¾" M Whip Hose
336075	¾" F x ¾" F NPTF Reconnectable Safe-T-Break® w/ ¾" M x ¾" M Whip Hose w/ Swivel Nut

Swivels

MODEL NO.	DESCRIPTION
0350	¾" M x ¾" F NPTF Multi-Plane Swivel
0350W	¾" M x ¾" F NPTF Multi-Plane Swivel with Warm Weather Seals
0355	" M x ¾" F NPTF Multi-Plane Swivel Anodized Black
2272	" M x ¾" F NPTF 90° Pump Swivel
2950	" M x ¾" F NPTF Multi-Plane Restricted Swivel

Swivel/Safe-T-Break® Combos

MODEL NO.	DESCRIPTION
6310	¾" M NPTF Multi-Plane Swivel connected to ¾" F NPTF Reconnectable Safe-T-Break®

Spouts

MODEL NO.	DESCRIPTION
6648	Complete Unleaded Spout Assembly Kit
7380	Complete Unleaded Drip Less Spout Assembly Kit
6651	Unleaded Spout Assembly
7385	Unleaded Drip Less Spout Assembly

Pressure/Vacuum Vents

MODEL NO.	DESCRIPTION
4620	2" Slip-On Pressure Vacuum Vent
4885	2" Thread-On Pressure Vacuum Vent - NPTF
5885	2" Thread-On Pressure Vacuum Vent with internal screen - NPTF

Guards

MODEL NO.	DESCRIPTION
6483	Full Grip Guard (includes Bellow and Slider Clamps)

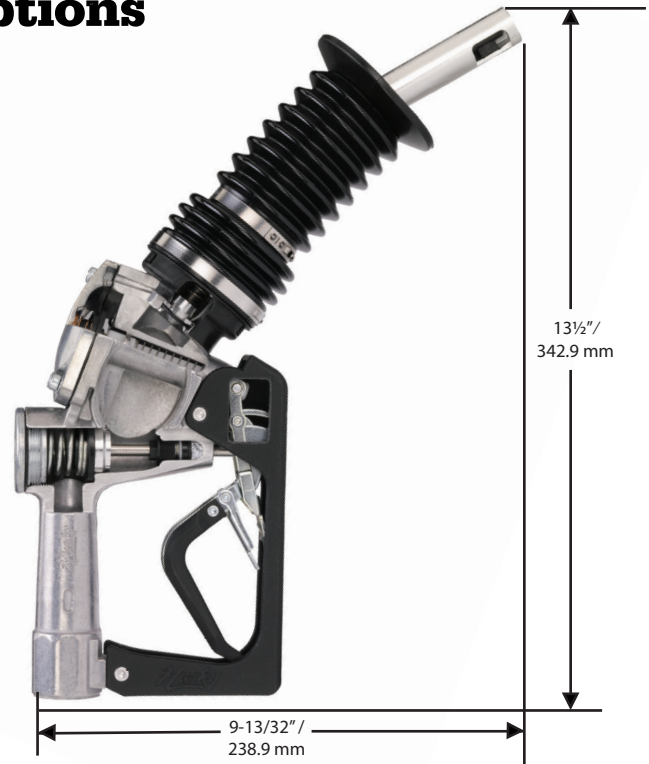

Accessories, Testing and Maintenance

MODEL NO.	DESCRIPTION
7089	Nozzle Service Kit
3593	Hold Open Clip Kit
0397	Unleaded Spout Gauge
4490	Conventional Flo-Equalizer™ - 10 gpm / 37.9 Lpm
7490	Internal Flo-Equalizer™ - 10 gpm / 37.9 Lpm
6649	Complete Bellows Assembly Kit
7381	Slider Assembly
7377	Collar Assembly
5920	Slider Clamp
5934	Bellow Clamp
6497	Oetiker Clamp Tool



MADE IN THE U.S.A.



Automatic shut-off nozzle for full-service and self-service stations.

- X nozzle shuts off when the gas tank is full.
- Aluminum reinforced spout bushing keeps spout tip round and acts as a captive fastener to prevent tip-end sensor damage.
- Equipped with a unique Flo-Stop™ device that shuts off the nozzle if it falls from the fill tank or raises above the horizontal.
- *StreamShaper™* reduces turbulence for straighter fuel flow and less splash back spillage.
- Comes standard with smooth full grip guard.



New Unleaded Nozzles

MODEL NO.	DESCRIPTION	SHIPPING WEIGHT LBS (KG)
159404	with Three Notch Hold Open Clip	3.0 (1.3)
E159404	with Three Notch Hold Open Clip and Mate Guard	3.1 (1.3)
159408	without Hold Open Clip	3.0 (1.3)
E159408	without Hold Open Clip, with Mate Guard	3.0 (1.3)
159424	with Three Notch Hold Open Clip and Sightglass	2.9 (1.3)
159454	with Three Notch Hold Open Clip and Flo-Equalizer™	3.0 (1.3)
159458	without Hold Open Clip, with Flo-Equalizer™	3.0 (1.3)
159464	with Three Notch Hold Open Clip and Waffle Splash Guard	2.7 (1.2)
159468	without Hold Open Clip, with Waffle Splash Guard	2.7 (1.2)

New Light Duty Diesel Nozzles

MODEL NO.	DESCRIPTION	SHIPPING WEIGHT LBS (KG)
159403	with Three Notch Hold Open Clip	3.1 (1.4)
E159403	with Three Notch Hold Open Clip and Mate Guard	3.1 (1.4)
159407	without Hold Open Clip	3.0 (1.3)
E159407	without Hold Open Clip, with Mate Guard	3.0 (1.3)
159453	with Three Notch Hold Open Clip and Flo-Equalizer™	3.1 (1.4)
159457	without Hold Open Clip, with Flo-Equalizer™	3.1 (1.3)
159463	with Three Notch Hold Open Clip and Waffle Splash Guard	2.8 (1.2)
159467	without Hold Open Clip, with Waffle Splash Guard	2.8 (1.2)

Construction

Body	One piece die cast aluminum
Seals	Fluorocarbon
Packing	Double o-ring seal protected by fiber reinforced Teflon
Lever	One piece contoured steel with hard plastic cover
Inlet	3/4" / 19 mm NPTF

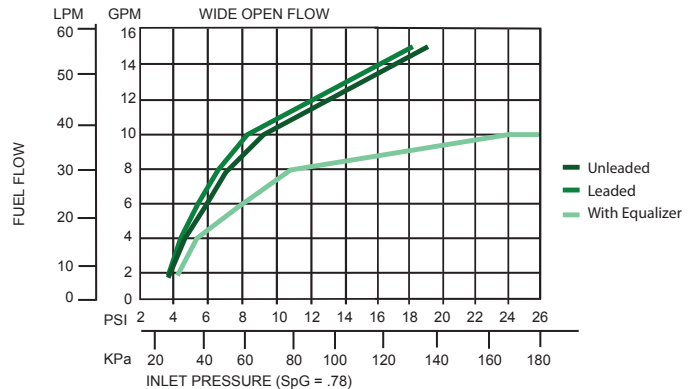

**Husky**

GENERAL FUELING PRODUCTS

X Nozzles**Automatic shut-off nozzle for full-service and self-service stations.**

Dimensions and System Options

Safe-T-Breaks®

MODEL NO.	DESCRIPTION
3360	¾" F x ¾" F NPTF Reconnectable Safe-T-Break®
2273	¾" F x ¾" F NPTF Non-Reconnectable Safe-T-Break®
6130	¾" F x ¾" F NPTF Non-Reconnectable PCC Safe-T-Break®
5230	¾" F x ¾" F NPTF Low Pull Reconnectable Safe-T-Break®

Swivels

MODEL NO.	DESCRIPTION
0350	¾" M x ¾" F NPTF Multi-Plane Swivel
0350W	¾" M x ¾" F NPTF Multi-Plane Swivel with Warm Weather Seals
0355	" M x ¾" F NPTF Multi-Plane Swivel Anodized Black
2272	" M x ¾" F NPTF 90° Pump Swivel
3895	" M x ¾" F NPTF Inline Swivel
2950	" M x ¾" F NPTF Multi-Plane Restricted Swivel

Swivel/Safe-T-Break® Combos

MODEL NO.	DESCRIPTION
6310	¾" M NPTF Multi-Plane Swivel connected to ¾" F NPTF Reconnectable Safe-T-Break®

Spouts

MODEL NO.	DESCRIPTION
1473	Unleaded Spout w/o Flo-Stop™
1471	Light Duty Diesel Spout w/o Flo-Stop™

Pressure/Vacuum Vents

MODEL NO.	DESCRIPTION
4620	2" Slip-On Pressure Vacuum Vent
4885	2" Thread-On Pressure Vacuum Vent - NPTF
5885	2" Thread-On Pressure Vacuum Vent with internal screen - NPTF

Accessories, Testing and Maintenance

MODEL NO.	DESCRIPTION
7089	Nozzle Service Kit
3593	Hold Open Clip Kit
0397	Unleaded Spout Gauge
4490	Conventional Flo-Equalizer™ - 10 gpm / 37.9 Lpm
7490	Internal Flo-Equalizer™ - 10 gpm / 37.9 Lpm

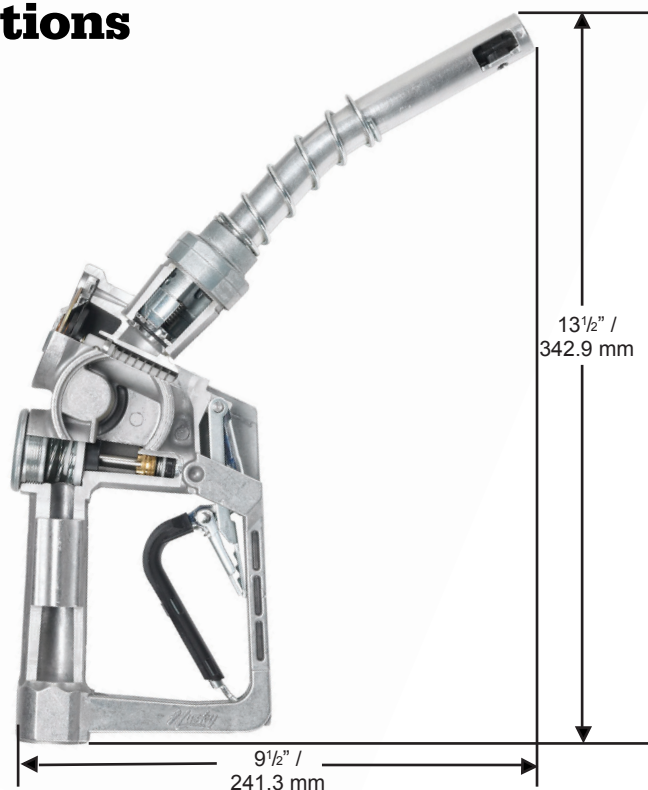

Guards

MODEL NO.	DESCRIPTION
4145	Full Grip Guard
6665	POPD™ S Full Grip Guard
8185	POPD™ H Full Grip Guard
1806	Full Grip Reguard
7205	POPD™ S Full Grip Reguard
8192	POPD™ H Full Grip Reguard
3795	Mate Guard
8165	POPD™ S Mate Guard
8166	POPD™ H Mate Guard
1808	Waffle Splash Guard
1506	Protection Package
1809	Reguard Protection Package
3440	Mate Easy-on Package
8175	POPD™ EZS Nozzle Guard
8176	POPD™ EZH Nozzle Guard
6628	POPD™ S Clear Cover
8181	POPD™ H Clear Cover
5494	Lever Guard
3376	Black Handle Guard



MADE IN THE U.S.A.



X BSPP Nozzles



Automatic shut-off nozzle for full-service and self-service stations.

- X nozzle shuts off when the gas tank is full.
- Aluminum reinforced spout bushing keeps the spout tip round and acts as a captive fastener to prevent tip-end sensor damage.
- Nozzle is equipped with a unique Flo-Stop™ device that shuts off the nozzle if it falls from the fill tank or raises above the horizontal.
- *StreamShaper™* reduces turbulence for straighter fuel flow and less splash back spillage.
- Comes standard with smooth full grip guard.



New Unleaded Nozzles

MODEL NO.	DESCRIPTION	SHIPPING WEIGHT LBS (KG)
159416	with Three Notch Hold Open Clip	3.0 (1.3)
159416A*	with Three Notch Hold Open Clip and Full Grip Guard - Atex	3.0 (1.3)
E159416	with Three Notch Hold Open Clip and Mate Guard	3.0 (1.3)
E159416A*	with Three Notch Hold Open Clip and Mate Guard - Atex	3.0 (1.3)
159487A*	with Three Notch Hold Open Clip, Full Grip Guard and Flo-Equalizer™	3.0 (1.3)
E538498	with Three Notch Hold Open Clip, Double Poppet, Waffle Splash Guard and POPD™ Mate Guard	3.0 (1.3)
159420	without Hold Open Clip	3.0 (1.3)
E159420	without Hold Open Clip, with Mate Guard	3.0 (1.3)

New Light Duty Diesel Nozzles

MODEL NO.	DESCRIPTION	SHIPPING WEIGHT LBS (KG)
159415	with Three Notch Hold Open Clip	3.1 (1.4)
159415A*	with Three Notch Hold Open Clip and Full Grip Guard - Atex	3.1 (1.4)
E159415	with Three Notch Hold Open Clip and Mate Guard	3.1 (1.4)
159486A*	with Three Notch Hold Open Clip, Full Grip Guard and Flo-Equalizer™	3.1 (1.4)
E538499	with Three Notch Hold Open Clip, Double Poppet, Waffle Splash Guard and POPD™ Mate Guard	3.1 (1.4)
159419	without Hold Open Clip	3.1 (1.4)
E159419	without Hold Open Clip, with Mate Guard	3.1 (1.4)

CONSTRUCTION

Body	One piece die cast aluminum
Seals	Fluorocarbon
Packing	Double o-ring seal protected by fiber reinforced Teflon
Lever	One piece contoured steel
Inlet	¾" / 19 mm NPTF Threads

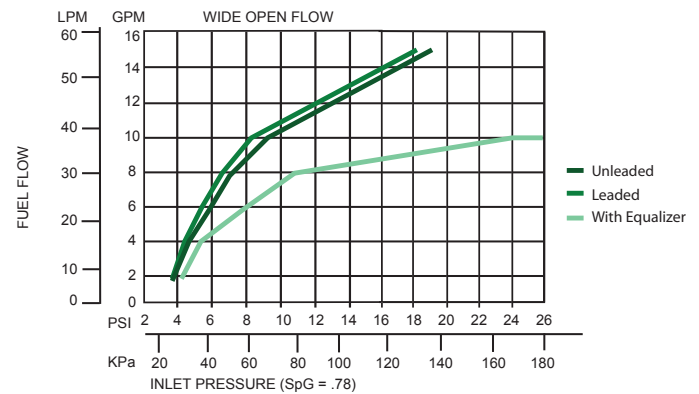

**Husky**

GENERAL FUELING PRODUCTS

X BSPP Nozzles

Automatic shut-off nozzle for full-service and self-service stations.

Dimensions and System Options

Safe-T-Breaks®

MODEL NO.	DESCRIPTION
3385	¾" F x ¾" F BSPP Reconnectable Safe-T-Break®
2774	¾" F x ¾" F BSPP Non-Reconnectable Safe-T-Break®

Swivels

MODEL NO.	DESCRIPTION
3590	¾" M x ¾" F BSPP Multi-Plane Swivel
3590W	¾" M x ¾" F BSPP Multi-Plane Swivel with Warm Weather Seals
2771	¾" M x ¾" F BSPP 90° Pump Swivel

Swivel/Safe-T-Break® Combos

MODEL NO.	DESCRIPTION
7085	¾" M BSPP Multi-Plane Swivel connected to ¾" F BSPP Reconnectable Safe-T-Break®

Spouts

MODEL NO.	DESCRIPTION
1473	Unleaded Spout without Flo-Stop™
1471	Light Duty Diesel Spout without Flo-Stop™

Pressure/Vacuum Vents

MODEL NO.	DESCRIPTION
4620	2" Slip-On Pressure Vacuum Vent
4885	2" Thread-On Pressure Vacuum Vent - NPTF
5885	2" Thread-On Pressure Vacuum Vent with internal screen - NPTF

Accessories, Testing and Maintenance

MODEL NO.	DESCRIPTION
7089	Nozzle Service Kit
3593	Hold Open Clip Kit
0397	Unleaded Spout Gauge
4490	Conventional Flo-Equalizer™ - 10 gpm / 37.9 Lpm
7490	Internal Flo-Equalizer™ - 10 gpm / 37.9 Lpm

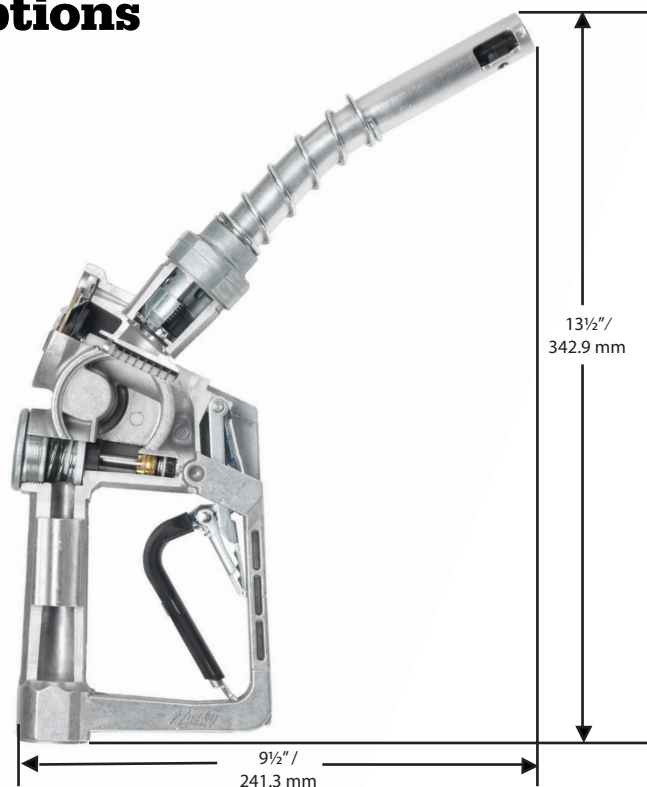

Guards

MODEL NO.	DESCRIPTION
4145	Full Grip Guard
6665	POPD™ S Full Grip Guard
8185	POPD™ H Full Grip Guard
1806	Full Grip Reguard
7205	POPD™ S Full Grip Reguard
8192	POPD™ H Full Grip Reguard
3795	Mate Guard
8165	POPD™ S Mate Guard
8166	POPD™ H Mate Guard
1808	Waffle Splash Guard
1506	Protection Package
1809	Reguard Protection Package
3440	Mate Easy-on Package
8175	POPD™ EZS Nozzle Guard
8176	POPD™ EZH Nozzle Guard
6628	POPD™ S Clear Cover
7999	POPD™ H Clear Cover
5494	Lever Guard
3376	Black Handle Cover



MADE IN THE U.S.A.



Automatic shut-off nozzle for self-service and full service stations.

- Aluminum reinforced spout bushing keeps the spout tip round and acts as a captive fastener to prevent tip-end sensor damage.
- Contains a poppet disc seal, rated at -40° F/C to prevent fuel leakage from the main seal in extreme cold weather.
- Nozzle is equipped with a unique Flo-Stop™ device that shuts off the nozzle if it falls from the fill tank or raises above the horizontal.
- *StreamShaper™* reduces turbulence for straighter fuel flow and less splash back spillage.
- Comes standard with smooth full grip guard.



New Unleaded Nozzles

MODEL NO.	DESCRIPTION	SHIPPING WEIGHT LBS (KG)
498404	with Three Notch Hold Open Clip	3.0 (1.3)
498408	without Hold Open Clip	3.0 (1.3)
498462	with Three Notch Hold Open Clip and Waffle Splash Guard	2.7 (1.2)

Rebuilt Unleaded Nozzles

MODEL NO.	DESCRIPTION	SHIPPING WEIGHT LBS (KG)
503704	with Three Notch Hold Open Clip	3.1 (1.4)

New Light Duty Diesel Nozzles

MODEL NO.	DESCRIPTION	SHIPPING WEIGHT LBS (KG)
498403	with Three Notch Hold Open Clip	3.1 (1.4)
498407	without Hold Open Clip	3.1 (1.4)
498461	with Three Notch Hold Open Clip and Waffle Splash Guard	2.8 (1.2)

Rebuilt Light Duty Diesel Nozzles

MODEL NO.	DESCRIPTION	SHIPPING WEIGHT LBS (KG)
503703	with Three Notch Hold Open Clip	3.1 (1.4)

Construction

Body	One piece die cast aluminum
Seals	Fluorocarbon
Packing	Double o-ring seal protected by fiber reinforced Teflon
Lever	One piece contoured steel
Inlet	3/4" / 19 mm NPTF Threads

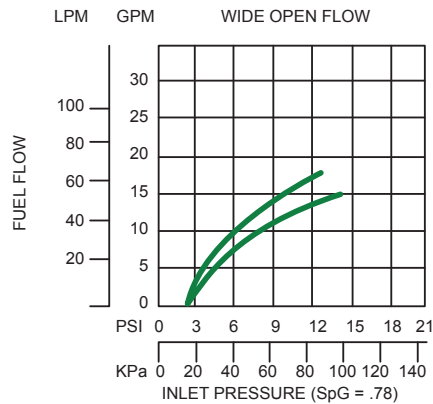

**Husky**

GENERAL FUELING PRODUCTS

**CW Nozzles****Automatic shut-off nozzle for full-service and self-service stations.**

Dimensions and System Options

Safe-T-Breaks®

MODEL NO.	DESCRIPTION
3360	¾" F x ¾" F NPTF Reconnectable Safe-T-Break®
2273	¾" F x ¾" F NPTF Non-Reconnectable Safe-T-Break®
6130	¾" F x ¾" F NPTF Non-Reconnectable PCC Safe-T-Break®
5230	¾" F x ¾" F NPTF Low Pull Reconnectable Safe-T-Break®

Swivels

MODEL NO.	DESCRIPTION
0350	¾" M x ¾" F NPTF Multi-plane Swivel
0355	¾" M x ¾" F NPTF Multi-plane Black Swivel
2272	¾" M x ¾" F NPTF 90° Pump Swivel
3895	¾" M x ¾" F NPTF Inline Swivel
2950	¾" M x ¾" F NPTF Multi-plane Restricted Swivel

Swivel/Safe-T-Break® Combos

MODEL NO.	DESCRIPTION
6310	¾" M NPTF Multi-plane Swivel connected to ¾" F NPTF Reconnectable Safe-T-Break®

Spouts

MODEL NO.	DESCRIPTION
1473	Unleaded Spout without Flo-Stop™
1471	Light Duty Diesel Spout without Flo-Stop™

Pressure/Vacuum Vents

MODEL NO.	DESCRIPTION
4620	2" Slip-On Pressure Vacuum Vent
4885	2" Thread-On Pressure Vacuum Vent - NPTF
5885	2" Thread-On Pressure Vacuum Vent with internal screen - NPTF

Accessories, Testing and Maintenance

MODEL NO.	DESCRIPTION
7089	Nozzle Service Kit
3593	Hold Open Clip Kit
0397	Unleaded Spout Gauge
4490	Conventional Flo-Equalizer™ - 10 gpm / 37.9 Lpm
7490	Internal Flo-Equalizer™ - 10 gpm / 37.9 Lpm

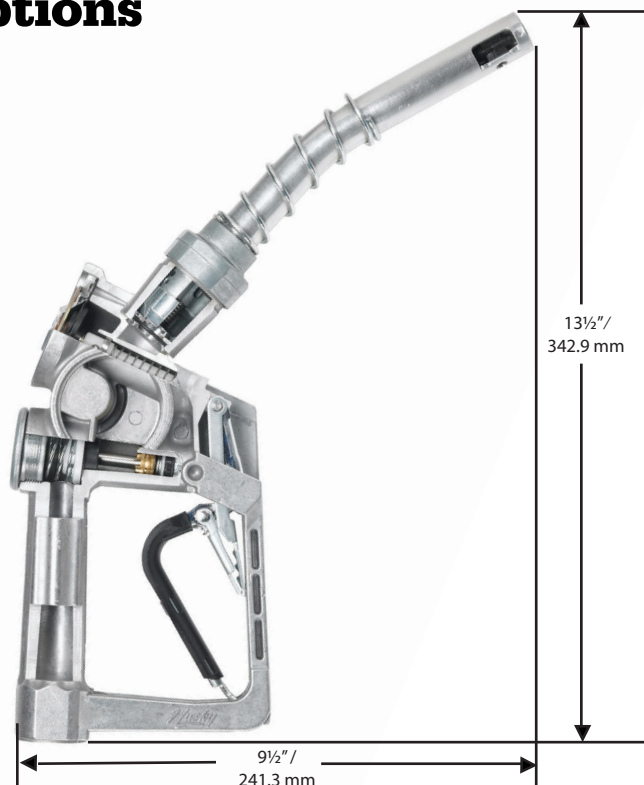

Guards

MODEL NO.	DESCRIPTION
4145	Full Grip Guard
6665	POPD™ S Full Grip Guard
8185	POPD™ H Full Grip Guard
1806	Full Grip Reguard
7205	POPD™ S Full Grip Reguard
8192	POPD™ H Full Grip Reguard
3795	Mate Guard
8165	POPD™ S Mate Guard
8166	POPD™ H Mate Guard
1808	Waffle Splash Guard
1506	Protection Package
1809	Reguard Protection Package
3440	Mate Easy-on Package
8175	POPD™ EZS Nozzle Guard
8176	POPD™ EZH Nozzle Guard
6628	POPD™ S Clear Cover
7999	POPD™ H Clear Cover
5494	Lever Guard
3376	Black Handle Cover



MADE IN THE U.S.A.



X DP Nozzles



Automatic shut-off nozzle for full-service and self-service stations.

- XS® Nozzle shuts off when
 - the pump shuts off.
 - the gas tank is full.
 - the lever is opened before the pump is turned on.
 - the leak detector has not completed the test cycle.
- Double Poppet allows “to the penny” dispensing.
- Double Poppet is a two (2) step closure reducing the amount of pressure spiking, or “hydraulic hammer”, and the adverse effects this has on the hose and dispenser meter.
- Aluminum reinforced spout bushing keeps spout tip round and acts as a captive fastener to prevent tip-end sensor damage.
- Equipped with a unique Flo-Stop™ device that shuts off the nozzle if it falls from the fill tank or raises above the horizontal.
- *StreamShaper™* reduces turbulence for straighter fuel flow and less splash back spillage.
- Comes standard with smooth full grip guard.



New Unleaded Nozzles w/ NPTF Threads

MODEL NO.	DESCRIPTION	SHIPPING WEIGHT LBS (KG)
539604	w/ Three Notch Hold Open Clip	3.1 (1.4)
539676	w/ Three Notch Hold Open Clip and Waffle Splash Guard	3.1 (1.4)

New Light Duty Diesel Nozzles w/ NPTF Threads

MODEL NO.	DESCRIPTION	SHIPPING WEIGHT LBS (KG)
539603	w/ Three Notch Hold Open Clip	3.1 (1.4)

New Unleaded Nozzles w/ BSPP Threads

MODEL NO.	DESCRIPTION	SHIPPING WEIGHT LBS (KG)
539616A*	w/ Three Notch Hold Open Clip - Atex	3.1 (1.4)
539632A	w/ Three Notch Hold Open Clip and Sightglass - Atex	3.1 (1.4)
E539616	w/ Three Notch Hold Open Clip and Mate Guard	3.1 (1.4)
E539687	w/ Three Notch Hold Open Clip Flo-Equalizer™ and Mate Guard	3.1 (1.4)
E539620	w/o Hold Open Clip w/ Mate Guard	3.1 (1.4)

New Light Duty Diesel Nozzles w/ BSPP Threads

MODEL NO.	DESCRIPTION	SHIPPING WEIGHT LBS (KG)
E359615	w/ Three Notch Hold Open Clip and Mate Guard	3.1 (1.4)
E539686	w/ Three Notch Hold Open Clip Flo-Equalizer™ and Mate Guard	3.1 (1.4)

Construction

Body	One piece die cast aluminum
Seals	Fluorocarbon
Packing	Double o-ring seal protected by fiber reinforced Teflon
Lever	One piece contoured steel with hard plastic cover
Inlet	¾" / 19 mm NPTF

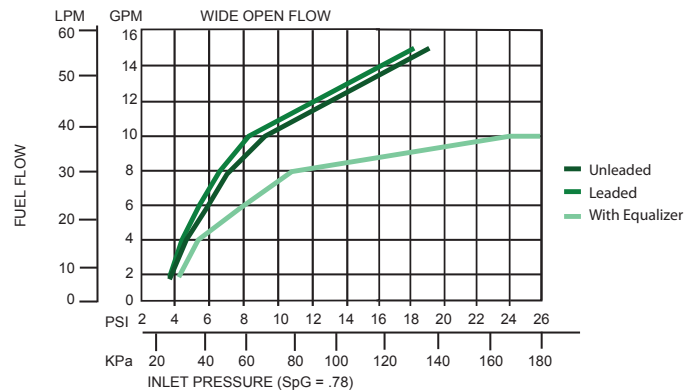

**Husky**

GENERAL FUELING PRODUCTS

X DP Nozzles

Automatic shut-off nozzle for full-service and self-service stations.

Dimensions and System Options

Safe-T-Breaks®

MODEL NO.	DESCRIPTION
3360	¾" F x ¾" F NPTF Reconnectable Safe-T-Break®
2273	¾" F x ¾" F NPTF Non-Reconnectable Safe-T-Break®
6130	¾" F x ¾" F NPTF Non-Reconnectable PCC Safe-T-Break®
5230	¾" F x ¾" F NPTF Low Pull Reconnectable Safe-T-Break®
3385	¾" F x ¾" F BSPP Reconnectable Safe-T-Break®
2774	¾" F x ¾" F BSPP Non-Reconnectable Safe-T-Break®

Swivels

MODEL NO.	DESCRIPTION
0350	¾" M x ¾" F NPTF Multi-Plane Swivel
0355	¾" M x ¾" F NPTF Multi-Plane Swivel Anodized Black
0350W	¾" M x ¾" F NPTF Multi-Plane Swivel w/ Warm Weather Seals
2272	¾" M x ¾" F NPTF 90° Pump Swivel
3895	¾" M x ¾" F NPTF Inline Swivel
2950	¾" M x ¾" F NPTF Multi-Plane Restricted Swivel
3590	¾" M x ¾" F BSPP Multi-Plane Swivel
3590W	¾" M x ¾" F BSPP Multi-Plane Swivel w/ Warm Weather Seals
2771	¾" M x ¾" F BSPP 90° Pump Swivel

Swivel/Safe-T-Break® Combos

MODEL NO.	DESCRIPTION
6310	¾" M NPTF Multi-Plane Swivel connected to ¾" F NPTF Reconnectable Safe-T-Break®
7085	¾" M BSPP Multi-Plane Swivel connected to ¾" F BSPP Reconnectable Safe-T-Break®

Pressure/Vacuum Vents

MODEL NO.	DESCRIPTION
4620	2" Slip-On Pressure Vacuum Vent
4885	2" Thread-On Pressure Vacuum Vent - NPTF
5885	2" Thread-On Pressure Vacuum Vent with internal screen - NPTF

Accessories, Testing and Maintenance

MODEL NO.	DESCRIPTION
7089	Nozzle Service Kit
3593	Hold Open Clip Kit
0397	Unleaded Spout Gauge
4490	Conventional Flo-Equalizer™ - 10 gpm / 37.9 Lpm
7490	Internal Flo-Equalizer™ - 10 gpm / 37.9 Lpm

Spouts

MODEL NO.	DESCRIPTION
1473	Unleaded Spout w/o Flo-Stop™
1471	Light Duty Diesel Spout w/o Flo-Stop™

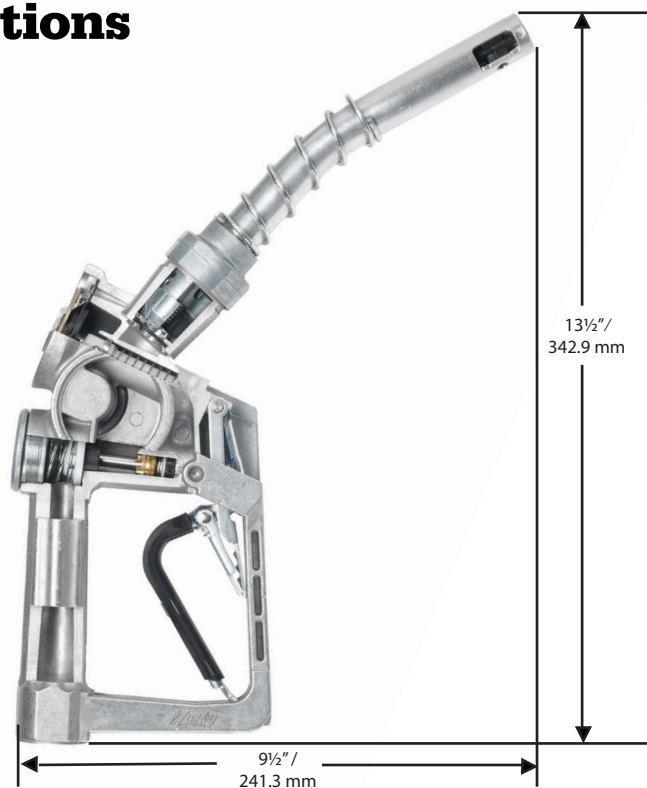

Guards

MODEL NO.	DESCRIPTION
4145	Full Grip Guard
6665	POPD™ S Full Grip Guard
8185	POPD™ H Full Grip Guard
1806	Full Grip Reguard
7205	POPD™ S Full Grip Reguard
8192	POPD™ H Full Grip Reguard
3795	Mate Guard
8165	POPD™ S Mate Guard
8166	POPD™ H Mate Guard
1808	Waffle Splash Guard
1506	Protection Package
1809	Reguard Protection Package
3440	Mate Easy-On Package
8175	POPD™ EZS Nozzle Guard
8176	POPD™ EZH Nozzle Guard
6628	POPD™ S Clear Cover
7999	POPD™ H Clear Cover
5494	Lever Guard
3376	Black Handle Cover



MADE IN THE U.S.A.



X Rebuilt Nozzles



Automatic shut-off nozzle for full-service and self-service stations.

- X nozzle shuts off when the gas tank is full.
- Aluminum reinforced spout bushing keeps the spout tip round and acts as a captive fastener to prevent tip-end sensor damage.
- Nozzle is equipped with a unique Flo-Stop™ device that shuts off the nozzle if it falls from the fill tank or raises above the horizontal.
- *StreamShaper™* reduces turbulence for straighter fuel flow and less splash back spillage.
- Comes standard with smooth full grip guard.



Rebuilt Unleaded Nozzles w/ NPTF

MODEL NO.	DESCRIPTION	SHIPPING WEIGHT LBS (KG)
265704	with Three Notch Hold Open Clip and Full Grip Nozzle Guard	3.1 (1.4)
E265704	with Three Notch Hold Open Clip and Mate Nozzle Guard	3.1 (1.4)
265708	without Hold Open Clip with Full Grip Nozzle Guard	3.1 (1.4)
E265708	without Hold Open Clip with Mate Nozzle Guard	3.1 (1.4)
265724	with Three Notch Hold Open Clip, Full Grip Nozzle Guard and Sightglass	3.1 (1.4)
265744	with Three Notch Hold Open Clip, Full Grip Nozzle Guard, Waffle Splash Guard and Flo-Equalizer™	3.1 (1.4)
265754	with Three Notch Hold Open Clip, Full Grip Nozzle Guard and Flo-Equalizer™	3.1 (1.4)
265758	without Hold Open Clip with Full Grip Nozzle Guard and Flo-Equalizer™	3.1 (1.4)
265764	with Three Notch Hold Open Clip, Full Grip Nozzle Guard and Waffle Splash Guard	3.1 (1.4)

Rebuilt Light Duty Diesel Nozzles w/ NPTF

MODEL NO.	DESCRIPTION	SHIPPING WEIGHT LBS (KG)
265703	with Three Notch Hold Open Clip and Full Grip Nozzle Guard	3.1 (1.4)
E265703	with Three Notch Hold Open Clip and Mate Nozzle Guard	3.1 (1.4)
265707	without Hold Open Clip with Full Grip Nozzle Guard	3.1 (1.4)
E265707	without Hold Open Clip with Mate Nozzle Guard	3.1 (1.4)
265745	with Three Notch Hold Open Clip, Full Grip Nozzle Guard, Waffle Splash Guard and Flo-Equalizer™	3.1 (1.4)
265753	with Three Notch Hold Open Clip, Full Grip Nozzle Guard and Flo-Equalizer™	3.1 (1.4)
265757	without Hold Open Clip with Full Grip Nozzle Guard and Flo-Equalizer™	3.1 (1.4)
265763	with Three Notch Hold Open Clip, Full Grip Nozzle Guard and Waffle Splash Guard	3.1 (1.4)

Construction

Body	One piece die cast aluminum
Seals	Fluorocarbon
Packing	Double o-ring seal protected by fiber reinforced Teflon
Lever	One piece contoured steel
Inlet	3/4" / 19 mm NPTF Threads

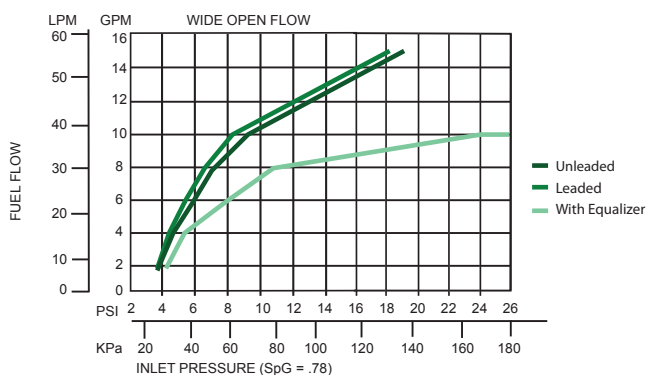

**Husky**

GENERAL FUELING PRODUCTS

X Rebuilt Nozzles**Automatic shut-off nozzle for full-service and self-service stations.****Dimensions and System Options****Safe-T-Breaks®**

MODEL NO.	DESCRIPTION
3360	¾" F x ¾" F NPTF Reconnectable Safe-T-Break®
2273	¾" F x ¾" F NPTF Non-Reconnectable Safe-T-Break®
6130	¾" F x ¾" F NPTF Non-Reconnectable PCC Safe-T-Break®
5230	¾" F x ¾" F NPTF Low Pull Reconnectable Safe-T-Break®

Swivels

MODEL NO.	DESCRIPTION
0350	¾" M x ¾" F NPTF Multi-Plane Swivel
0350W	¾" M x ¾" F NPTF Multi-Plane Swivel w/ Warm Weather Seals
0355	¾" M x ¾" F NPTF Multi-Plane Swivel Anodized Black
2272	¾" M x ¾" F NPTF 90° Pump Swivel
3895	¾" M x ¾" F NPTF Inline Swivel
2950	¾" M x ¾" F NPTF Multi-Plane Restricted Swivel

Swivel/Safe-T-Break® Combos

MODEL NO.	DESCRIPTION
6310	¾" M NPTF Multi-Plane Swivel connected to ¾" F NPTF Reconnectable Safe-T-Break®

Spouts

MODEL NO.	DESCRIPTION
1473	Unleaded Spout without Flo-Stop™
1471	Light Duty Diesel Spout without Flo-Stop™

Pressure/Vacuum Vents

MODEL NO.	DESCRIPTION
4620	2" Slip-On Pressure Vacuum Vent
4885	2" Thread-On Pressure Vacuum Vent - NPTF
5885	2" Thread-On Pressure Vacuum Vent with internal screen - NPTF

Accessories, Testing, and Maintenance

MODEL NO.	DESCRIPTION
7089	Nozzle Service Kit
3593	Hold Open Clip Kit
0397	Unleaded Spout Gauge
4490	Conventional Flo-Equalizer™ - 10 gpm / 37.9 Lpm
7490	Internal Flo-Equalizer™ - 10 gpm / 37.9 Lpm

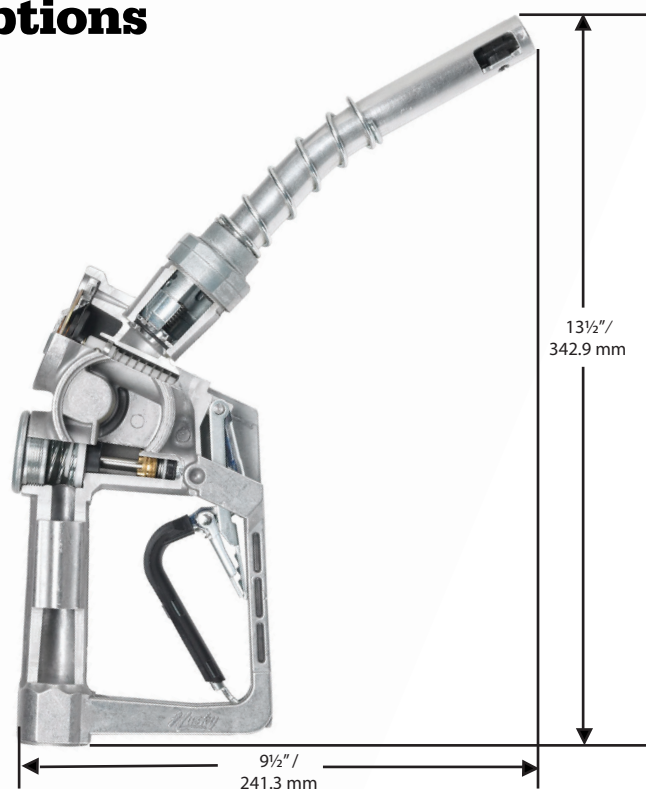
**Guards**

MODEL NO.	DESCRIPTION
4145	Full Grip Guard
6665	POPD™ S Full Grip Guard
8185	POPD™ H Full Grip Guard
1806	Full Grip Reguard
7205	POPD™ S Full Grip Reguard
8192	POPD™ H Full Grip Reguard
3795	Mate Guard
8165	POPD™ S Mate Guard
8166	POPD™ H Mate Guard
1808	Waffle Splash Guard
1506	Protection Package
1809	Reguard Protection Package
3440	Mate Easy-on Package
8175	POPD™ EZS Nozzle Guard
8176	POPD™ EZH Nozzle Guard
6628	POPD™ S Clear Cover
7999	POPD™ H Clear Cover
5494	Lever Guard
3376	Black Handle Cover



MADE IN THE U.S.A.



X Sightglass Nozzles



Husky

GENERAL FUELING PRODUCTS

Automatic shut off nozzle for full-service and self-service stations.

- X® nozzle shuts off when the gas tank is full.
- Sightglass on nozzle allows customer to see fuel flow through nozzle.
- Stainless steel reinforced spout bushing keeps spout tip round and acts as a captive fastener to prevent tip-end sensor damage.
- StreamShaper™ reduces turbulence for straighter fuel flow and less splash back spillage.
- Equipped with a unique Flo- Stop™ device that shuts off the nozzle if it falls from the fill tank or raises above the horizontal.
- Comes standard with smooth full grip guard.



New Unleaded Nozzles

MODEL NO.	DESCRIPTION	SHIPPING WEIGHT LBS (KG)
159424	w/ Three Notch Hold Open Clip	3.0 (1.3)
E159424	w/ Three Notch Hold Open Clip and Mate Guard	3.1 (1.4)
538424	without Hold Open Clip and Double Poppet	3.1 (1.4)
159428	without Hold Open Clip	3.0 (1.3)
E159428	without Hold Open Clip, with Mate Guard	3.0 (1.3)

New Light Duty Diesel Nozzles

MODEL NO.	DESCRIPTION	SHIPPING WEIGHT LBS (KG)
159423	w/ Three Notch Hold Open Clip	3.1 (1.4)
E159423	w/ Three Notch Hold Open Clip w/ Mate Guard	3.1 (1.4)
538423	with Three Notch Hold Open Clip and Double Poppet	3.1 (1.4)
159427	without Hold Open Clip	3.0 (1.3)
E159427	without Hold Open Clip w/ Mate Guard	3.0 (1.3)

Construction

Body	One piece die cast aluminum
Seals	Fluorocarbon
Packing	Double o-ring seal protected by fiber reinforced Teflon
Lever	One piece contoured steel with hard plastic cover
Inlet	¾" / 19.1 mm NPTF

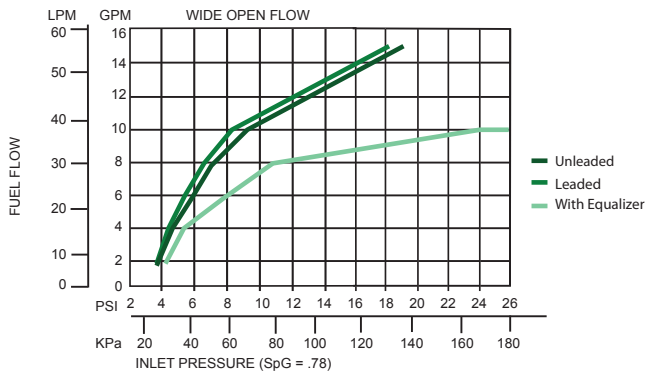

**Husky**

GENERAL FUELING PRODUCTS



Sightglass Nozzles

Automatic shut off nozzle for full-service and self-service stations.

Dimensions and System Options

Safe-T-Breaks®

MODEL NO.	DESCRIPTION
3360	¾" F x ¾" F NPTF Reconnectable Safe-T-Break®
2273	¾" F x ¾" F NPTF Non-Reconnectable Safe-T-Break®
6130	¾" F x ¾" F NPTF Non-Reconnectable PCC Safe-T-Break®
5230	¾" F x ¾" F NPTF Low Pull Reconnectable Safe-T-Break®

Swivels

MODEL NO.	DESCRIPTION
0350	¾" M x ¾" F NPTF Multi-Plane Swivel
0350W	¾" M x ¾" F NPTF Multi-Plane Swivel with Warm Weather Seals
0355	¾" M x ¾" F NPTF Multi-Plane Swivel Anodized Black
2272	¾" M x ¾" F NPTF 90° Pump Swivel
3895	¾" M x ¾" F NPTF Inline Swivel
2950	¾" M x ¾" F NPTF Multi-Plane Restricted Swivel

Swivel/Safe-T-Break® Combos

MODEL NO.	DESCRIPTION
6310	¾" M NPTF Multi-Plane Swivel connected to ¾" F NPTF Reconnectable Safe-T-Break®

Spouts

MODEL NO.	DESCRIPTION
1473	Unleaded Spout without Flo-Stop™
1471	Light Duty Diesel Spout without Flo-Stop™

Pressure/Vacuum Vents

MODEL NO.	DESCRIPTION
4620	2" Slip-On Pressure Vacuum Vent
4885	2" Thread-On Pressure Vacuum Vent - NPTF
5885	2" Thread-On Pressure Vacuum Vent with internal screen - NPTF

Accessories, Testing and Maintenance

MODEL NO.	DESCRIPTION
7089	Nozzle Service Kit
3593	Hold Open Clip Kit
0397	Unleaded Spout Gauge
4490	Conventional Flo-Equalizer™ - 10 gpm / 37.9 Lpm
7490	Internal Flo-Equalizer™ - 10 gpm / 37.9 Lpm

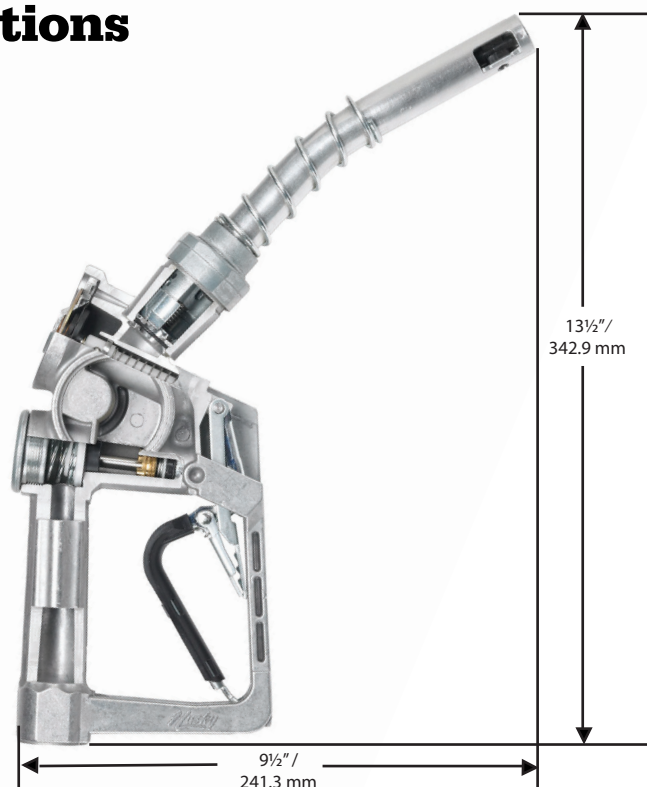

Guards

MODEL NO.	DESCRIPTION
4145	Full Grip Guard
6665	POPD™ S Full Grip Guard
8185	POPD™ H Full Grip Guard
1806	Full Grip Reguard
7205	POPD™ S Full Grip Reguard
8192	POPD™ H Full Grip Reguard
3795	Mate Guard
8165	POPD™ S Mate Guard
8166	POPD™ H Mate Guard
8175	POPD™ EZS Nozzle Guard
8176	POPD™ EZH Nozzle Guard
1808	Waffle Splash Guard
1506	Protection Package
1809	Reguard Protection Package
3440	Mate Easy-on Package
6628	POPD™ S Clear Cover
8181	POPD™ H Clear Cover
5494	Lever Guard
3376	Black Handle Guard



MADE IN THE U.S.A.



Pressure Activated, automatic shut-off nozzle for full-service and self-service stations.

- XS® Nozzle shuts off when
 - the pump shuts off.
 - the gas tank is full.
 - the lever is opened before the pump is turned on.
 - the leak detector has not completed the test cycle.
- *StreamShaper™* reduces turbulence for straighter fuel flow and less splash back spillage.
- Comes standard with smooth full grip guard.
- Stainless steel spout bushing keeps spout tip round and acts as a captive fastener to prevent tip-end sensor damage.
- Equipped with a unique Flo-Stop™ device that shuts off the nozzle if it falls from the fill tank or raises above the horizontal.

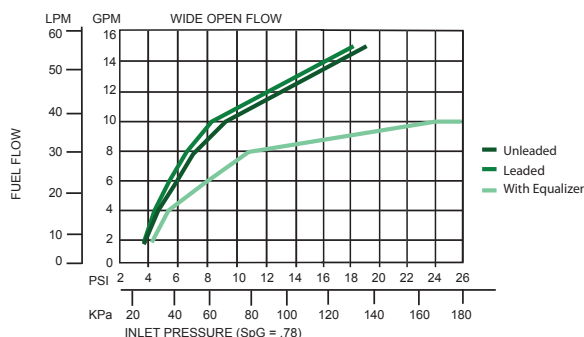
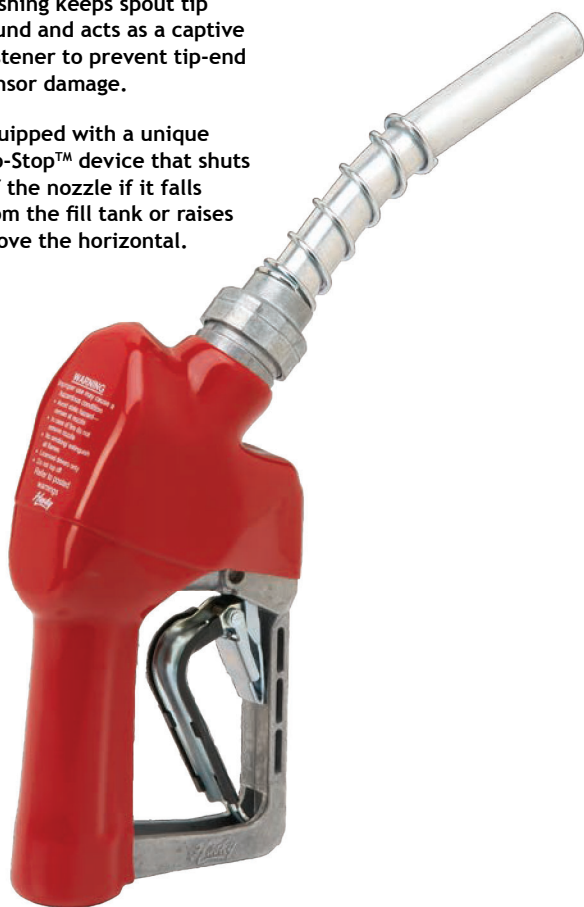

New Unleaded Nozzles

MODEL NO.	DESCRIPTION	SHIPPING WEIGHT LBS (KG)
159504	with Three Notch Hold Open Clip	3.1 (1.4)
E159504	with Three Notch Hold Open Clip & Mate Guard	3.1 (1.4)
159508	without Hold Open Clip	3.1 (1.4)
E159508	without Hold Open Clip, w/ Mate Guard	3.1 (1.4)
159524	with Three Notch Hold Open Clip and Sightglass	2.9 (1.3)
159543	with Single Notch Hold Open Clip and 1808 Waffle Splash Guard	3.1 (1.4)
159544	with Three Notch Hold Open Clip, 1808 Waffle Splash Guard and Flo-Equalizer	3.2 (1.4)
159554	with Three Notch Hold Open Clip & Flo-Equalizer™	3.1 (1.4)
159558	without Hold Open Clip w/ Flo-Equalizer™	3.1 (1.4)
159559	with Three Notch Hold Open Clip and 1808 Waffle Splash Guard	3.0 (1.3)
159566	without Hold Open Clip w/ 1808 Waffle Splash Guard	3.0 (1.3)
159576	with Three Notch Hold Open Clip and 1807 Waffle Splash Guard	3.0 (1.3)
159579	without Hold Open Clip w/ 1807 Waffle Splash Guard	3.0 (1.3)
159589	with Single Notch Hold Open Clip, POPD™ Full Grip Guard & 1808 Waffle Splash Guard	3.0 (1.3)
159595	with Three Notch Hold Open Clip, POPD™ Full Grip Guard & 1808 Waffle Splash Guard	3.1 (1.4)

New Light Duty Diesel Nozzles

MODEL NO.	DESCRIPTION	SHIPPING WEIGHT LBS (KG)
159503	with Three Notch Hold Open Clip	3.1 (1.4)
E159503	with Three Notch Hold Open Clip & Mate Guard	3.1 (1.4)
159507	without Hold Open Clip	3.1 (1.4)
E159507	without Hold Open Clip w/ Mate Guard	3.1 (1.4)
159545	with Three Notch Hold Open Clip, 1808 Waffle Splash Guard and Flo-Equalizer™	3.2 (1.4)
159553	with Three Notch Hold Open Clip & Flo-Equalizer™	3.1 (1.4)
159557	without Hold Open Clip w/ Flo-Equalizer™	3.1 (1.4)
159561	with Three Notch Hold Open Clip and 1808 Waffle Splash Guard	3.0 (1.3)
159567	without Hold Open Clip w/ 1808 Waffle Splash Guard	3.1 (1.4)
159577	with Single Notch Clip, POPD™ Full Grip Guard and 1808 Waffle Splash Guard	3.3 (1.4)
159578	with Three Notch Hold Open Clip, and 1808 Waffle Splash Guard	3.3 (1.4)
159580	without Hold Open Clip w/ 1807 Waffle Splash Guard	3.1 (1.4)
159585	with Single Notch Hold Open Clip, 1808 Waffle Splash Guard and Flo-Equalizer™	3.1 (1.4)
159596	with Three Notch Hold Open Clip, POPD™ Full Grip Guard and 1808 Waffle Splash Guard	3.3 (1.4)
159597	with Single Notch Hold Open Clip and 1808 Waffle Splash Guard	3.1 (1.4)

Construction

Body	One piece die cast aluminum
Seals	Fluorocarbon
Packing	Double o-ring seal protected by fiber reinforced Teflon
Lever	One piece contoured steel with hard plastic cover
Inlet	1" / 25.4 mm NPTF & BSPP



**Husky**

GENERAL FUELING PRODUCTS

XS Nozzles

Pressure activated, automatic shut-off nozzle for full-service and self-service stations.

Dimensions and System Options

Safe-T-Breaks®

MODEL NO.	DESCRIPTION
3360	¾" F x ¾" F NPTF Reconnectable Safe-T-Break®
2273	¾" F x ¾" F NPTF Non-Reconnectable Safe-T-Break®
6130	¾" F x ¾" F NPTF Non-Reconnectable PCC Safe-T-Break®
5230	¾" F x ¾" F NPTF Low Pull Reconnectable Safe-T-Break®

Swivels

MODEL NO.	DESCRIPTION
0350	¾" M x ¾" F NPTF Multi-Plane Swivel
0350W	¾" M x ¾" F NPTF Multi-Plane Swivel with Warm Weather Seals
0355	¾" M x ¾" F NPTF Multi-Plane Swivel Anodized Black
2272	¾" M x ¾" F NPTF 90° Pump Swivel
3895	¾" M x ¾" F NPTF Inline Swivel
2950	¾" M x ¾" F NPTF Multi-Plane Restricted Swivel

Swivel/Safe-T-Break® Combos

MODEL NO.	DESCRIPTION
6310	¾" M NPTF Multi-Plane Swivel connected to ¾" F NPTF Reconnectable Safe-T-Break®

Spouts

MODEL NO.	DESCRIPTION
1473	Unleaded Spout w/o Flo-Stop™
1471	Light Duty Diesel Spout w/o Flo-Stop™

Pressure/Vacuum Vents

MODEL NO.	DESCRIPTION
4620	2" Slip-On Pressure Vacuum Vent
4885	2" Thread-On Pressure Vacuum Vent - NPTF
5885	2" Thread-On Pressure Vacuum Vent with internal screen - NPTF

Accessories, Testing and Maintenance

MODEL NO.	DESCRIPTION
7089	Nozzle Service Kit
3593	Hold Open Clip Kit
0397	Unleaded Spout Gauge
4490	Conventional Flo-Equalizer™ - 10 gpm / 37.9 Lpm
7490	Internal Flo-Equalizer™ - 10 gpm / 37.9 Lpm

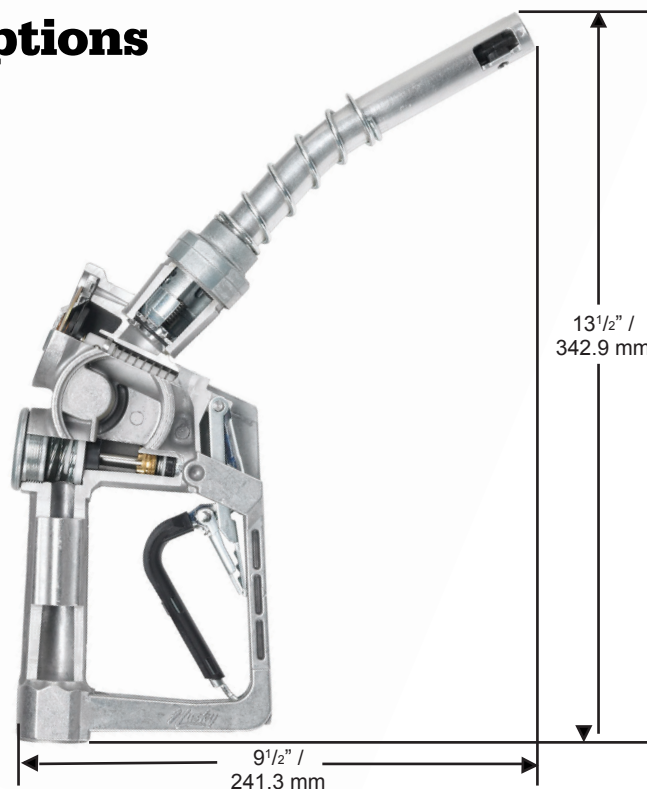

Guards

MODEL NO.	DESCRIPTION
4145	Full Grip Guard
6665	POPD™ S Full Grip Guard
8185	POPD™ H Full Grip Guard
1806	Full Grip Reguard
7205	POPD™ S Full Grip Reguard
8192	POPD™ H Full Grip Reguard
3795	Mate Guard
8165	POPD™ S Mate Guard
8166	POPD™ H Mate Guard
8175	POPD™ EZS Nozzle Guard
8176	POPD™ EZH Nozzle Guard
1808	Waffle Splash Guard
1506	Protection Package
1809	Reguard Protection Package
3440	Mate Easy-on Package
6628	POPD™ S Clear Cover
8181	POPD™ H Clear Cover
5494	Lever Guard
3376	Black Handle Guard



MADE IN THE U.S.A.



XS BSPP Nozzles



Husky

GENERAL FUELING PRODUCTS

1-11

CONVENTIONAL FUELING

Pressure activated, automatic shut off nozzle for full-service, self-service and unattended stations.

- XS® Nozzle shuts off when:
 - the pump shuts off.
 - the gas tank is full.
 - the lever is opened before the pump is turned on.
 - the leak detector has not completed the test cycle
- Aluminum reinforced spout bushing keeps the spout tip round and acts as a captive fastener to prevent tip-end sensor damage.
- Nozzle is equipped with a unique Flo-Stop™ device that shuts off the nozzle if it falls from the fill tank or raises above the horizontal.
- StreamShaper™ reduces turbulence for straighter fuel flow and less splash back spillage.
- Comes standard with smooth full grip guard.



New Unleaded Nozzles

MODEL NO.	DESCRIPTION	SHIPPING WEIGHT LBS (KG)
159516	with Three Notch Hold Open Clip and Full Grip Guard	3.0 (1.3)
159516A*	with Three Notch Hold Open Clip and Full Grip Guard - Atex	3.0 (1.3)
E159516	with Three Notch Hold Open Clip and Mate Guard	3.1 (1.4)
159520	without Hold Open Clip, with Full Grip Guard	3.0 (1.3)
E159520	without Hold Open Clip, with Mate Guard	3.1 (1.4)

Rebuilt Unleaded Nozzles

MODEL NO.	DESCRIPTION	SHIPPING WEIGHT LBS (KG)
159515	with Three Notch Hold Open Clip and Full Grip Guard	3.0 (1.3)
E159515	with Three Notch Hold Open Clip and Mate Guard	3.1 (1.4)
159519	without Hold Open Clip, with Full Grip Guard	3.0 (1.3)
E159519	without Hold Open Clip, with Mate Guard	3.1 (1.4)

Construction

Body	One piece die cast aluminum
Seals	Fluorocarbon
Packing	Double o-ring seal protected by fiber reinforced Teflon
Lever	One piece contoured steel with hard plastic cover
Inlet	¼" / 19.1 mm BSPP

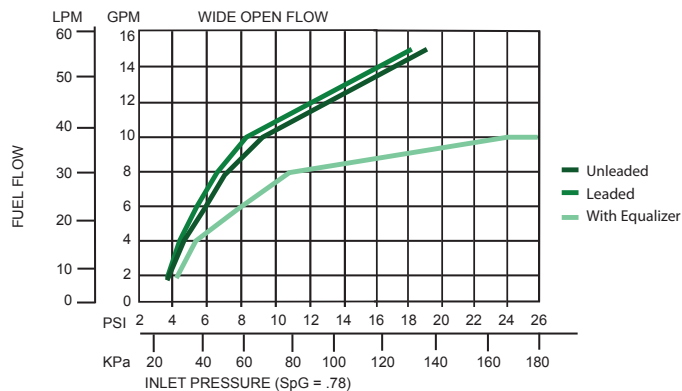

**Husky**

GENERAL FUELING PRODUCTS

XS BSPP Nozzles

Pressure activated, automatic shut off nozzle for full-service, self-service and unattended stations.

Dimensions and System Options

Safe-T-Breaks®

MODEL NO.	DESCRIPTION
3385	¾" F x ¾" F BSPP Reconnectable Safe-T-Break®
2774	¾" F x ¾" F BSPP Non-Reconnectable Safe-T-Break®

Swivels

MODEL NO.	DESCRIPTION
3590	¾" M x ¾" F BSPP Multi-Plane Swivel
3590W	¾" M x ¾" F BSPP Multi-Plane Swivel w/ Warm Weather Seals
2771	¾" M x ¾" F BSPP 90° Pump Swivel

Swivel/Safe-T-Break® Combos

MODEL NO.	DESCRIPTION
7085	¾" M BSPP Multi-Plane Swivel connected to ¾" F BSPP Reconnectable Safe-T-Break®

Spouts

MODEL NO.	DESCRIPTION
1473	Unleaded Spout without Flo-Stop™
1471	Light Duty Diesel Spout without Flo-Stop™

Pressure/Vacuum Vents

MODEL NO.	DESCRIPTION
4620	2" Slip-On Pressure Vacuum Vent
4885	2" Thread-On Pressure Vacuum Vent - NPTF
5885	2" Thread-On Pressure Vacuum Vent with internal screen - NPTF

Accessories, Testing, and Maintenance

MODEL NO.	DESCRIPTION
7089	Nozzle Service Kit
3593	Hold Open Clip Kit
0397	Unleaded Spout Gauge
7490	Internal Flo-Equalizer™ - 10 gpm / 37.9 Lpm

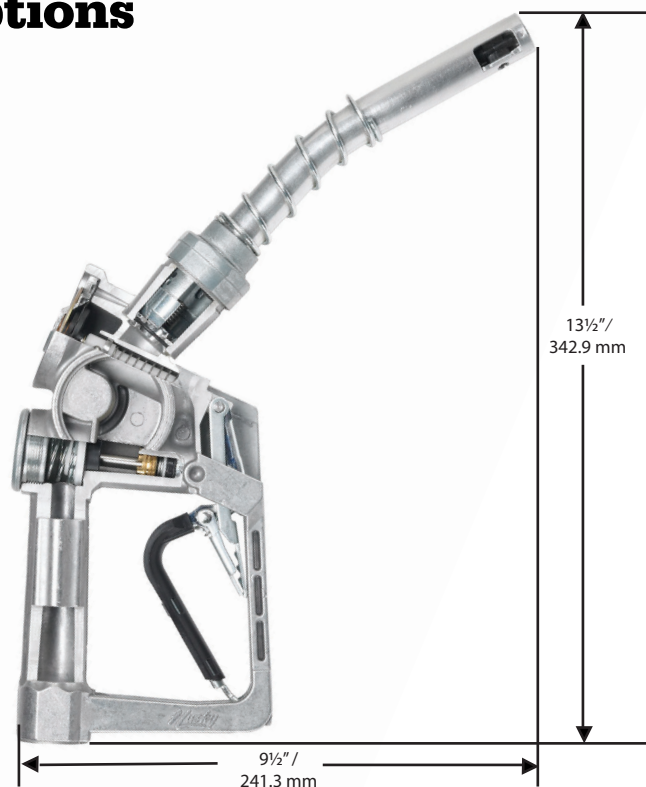

Guards

MODEL NO.	DESCRIPTION
4145	Full Grip Guard
6665	POPD™ S Full Grip Guard
8185	POPD™ H Full Grip Guard
1806	Full Grip Reguard
7205	POPD™ S Full Grip Reguard
8192	POPD™ H Full Grip Reguard
3795	Mate Guard
8165	POPD™ S Mate Guard
8166	POPD™ H Mate Guard
1808	Waffle Splash Guard
1506	Protection Package
1809	Reguard Protection Package
3440	Mate Easy-on Package
8175	POPD™ EZS Nozzle Guard
8176	POPD™ EZH Nozzle Guard
6628	POPD™ S Clear Cover
7999	POPD™ H Clear Cover
5494	Lever Guard
3376	Black Handle Cover



MADE IN THE U.S.A.



XS CW Nozzles



Pressure activated, automatic shut-off nozzle for self-service, full service and unattended stations.

- XS® Nozzle shuts off when:
 - the pump shuts off.
 - the gas tank is full.
 - the lever is opened before the pump is turned on.
 - the leak detector has not completed the test cycle.
- Aluminum reinforced spout bushing keeps the spout tip round and acts as a captive fastener to prevent tip-end sensor damage.
- Contains a poppet disc seal, rated at -40° F/C to prevent fuel leakage from the main seal in extreme cold weather.
- Nozzle is equipped with a unique Flo-Stop™ device that shuts off the nozzle if it falls from the fill tank or raises above the horizontal.
- StreamShaper™ reduces turbulence for straighter fuel flow and less splash back spillage.
- Comes standard with smooth full grip guard.



New Unleaded Nozzles

MODEL NO.	DESCRIPTION	SHIPPING WEIGHT LBS (KG)
498104	with Three Notch Hold Open Clip	3.1 (1.4)
498108	without Hold Open Clip	3.1 (1.4)
498162	with Three Notch Hold Open Clip and 1808 Waffle Splash Guard	3.0 (1.3)

Rebuilt Unleaded Nozzles

MODEL NO.	DESCRIPTION	SHIPPING WEIGHT LBS (KG)
503904	with Three Notch Hold Open Clip	3.1 (1.4)

New Light Duty Diesel Nozzles

MODEL NO.	DESCRIPTION	SHIPPING WEIGHT LBS (KG)
498103	with Three Notch Hold Open Clip	3.1 (1.4)
498107	without Hold Open Clip	3.1 (1.4)
498161	with Three Notch Hold Open Clip and 1808 Waffle Splash Guard	3.0 (1.3)
498167	without Hold Open Clip, with 1808 Waffle Splash Guard	3.1 (1.4)

Rebuilt Light Duty Diesel Nozzles

MODEL NO.	DESCRIPTION	SHIPPING WEIGHT LBS (KG)
503903	with Three Notch Hold Open Clip	.1 (1.4)

Construction

Body	One piece die cast aluminum
Seals	Fluorocarbon
Packing	Double o-ring seal protected by fiber reinforced Teflon
Lever	One piece contoured steel
Inlet	¼" / 19 mm NPTF Threads

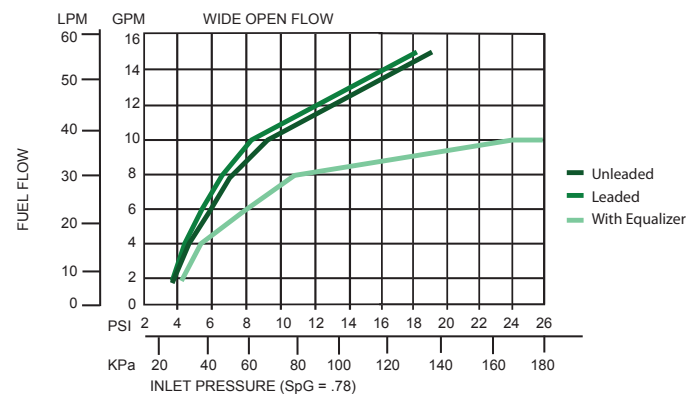

**Husky**

GENERAL FUELING PRODUCTS

XS CW Nozzles

Automatic shut-off nozzle for full-service and self-service stations.

Dimensions and System Options

Safe-T-Breaks®

MODEL NO.	DESCRIPTION
3360	¾" F x ¾" F NPTF Reconnectable Safe-T-Break®
2273	¾" F x ¾" F NPTF Non-Reconnectable Safe-T-Break®
6130	¾" F x ¾" F NPTF Non-Reconnectable PCC Safe-T-Break®
5230	¾" F x ¾" F NPTF Low Pull Reconnectable Safe-T-Break®

Swivels

MODEL NO.	DESCRIPTION
0350	¾" M x ¾" F NPTF Multi-plane Swivel
0355	¾" M x ¾" F NPTF Multi-plane Black Swivel
2272	¾" M x ¾" F NPTF 90° Pump Swivel
3895	¾" M x ¾" F NPTF Inline Swivel
2950	¾" M x ¾" F NPTF Multi-plane Restricted Swivel

Swivel/Safe-T-Break® Combos

MODEL NO.	DESCRIPTION
6310	¾" M NPTF Multi-plane Swivel connected to ¾" F NPTF Reconnectable Safe-T-Break®

Spouts

MODEL NO.	DESCRIPTION
1473	Unleaded Spout without Flo-Stop™
1471	Light Duty Diesel Spout without Flo-Stop™

Pressure/Vacuum Vents

MODEL NO.	DESCRIPTION
4620	2" Slip-On Pressure Vacuum Vent
4885	2" Thread-On Pressure Vacuum Vent - NPTF
5885	2" Thread-On Pressure Vacuum Vent with internal screen - NPTF

Accessories, Testing, and Maintenance

MODEL NO.	DESCRIPTION
7089	Nozzle Service Kit
3593	Hold Open Clip Kit
0397	Unleaded Spout Gauge
4490	Conventional Flo-Equalizer™ - 10 gpm / 37.9 Lpm
7490	Internal Flo-Equalizer™ - 10 gpm / 37.9 Lpm

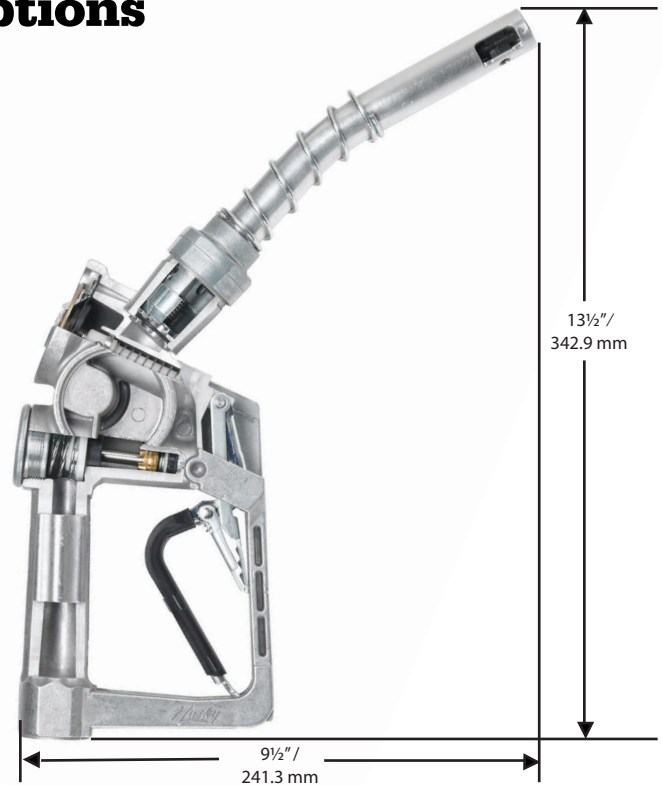

Guards

MODEL NO.	DESCRIPTION
4145	Full Grip Guard
6665	POPD™ S Full Grip Guard
8185	POPD™ H Full Grip Guard
1806	Full Grip Reguard
7205	POPD™ S Full Grip Reguard
8192	POPD™ H Full Grip Reguard
3795	Mate Guard
8165	POPD™ S Mate Guard
8166	POPD™ H Mate Guard
1808	Waffle Splash Guard
1506	Protection Package
1809	Reguard Protection Package
3440	Mate Easy-on Package
8175	POPD™ EZS Nozzle Guard
8176	POPD™ EZH Nozzle Guard
6628	POPD™ S Clear Cover
7999	POPD™ H Clear Cover
5494	Lever Guard
3376	Black Handle Cover



MADE IN THE U.S.A.



XS DP Nozzles



Pressure Activated, automatic shut-off nozzle for full-service and self-service stations.

- XS® Nozzle shuts off when
 - the pump shuts off.
 - the gas tank is full.
 - the lever is opened before the pump is turned on.
 - the leak detector has not completed the test cycle.
- Double Poppet allows “to the penny” dispensing.
- Double Poppet is a two(2) step closure reducing the amount of pressure spiking, or “hydraulic hammer”, and the adverse effects this has on the hose and dispenser meter.
- Aluminum reinforced spout bushing keeps spout tip round and acts as a captive fastener to prevent tip-end sensor damage.
- Equipped with a unique Flo-Stop™ device that shuts off the nozzle if it falls from the fill tank or raises above the horizontal.
- *StreamShaper™* reduces turbulence for straighter fuel flow and less splash back spillage.
- Comes standard with smooth full grip guard.

New Unleaded Nozzles w/ NPTF Threads

MODEL NO.	DESCRIPTION	SHIPPING WEIGHT LBS (KG)
539604	w/ Three Notch Hold Open Clip	3.1 (1.4)
539676	w/ Three Notch Hold Open Clip and Waffle Splash Guard	3.1 (1.4)

New Light Duty Diesel Nozzles w/ NPTF Threads

MODEL NO.	DESCRIPTION	SHIPPING WEIGHT LBS (KG)
539603	w/ Three Notch Hold Open Clip	3.1 (1.4)

New Unleaded Nozzles w/ BSPP Threads

MODEL NO.	DESCRIPTION	SHIPPING WEIGHT LBS (KG)
539616A*	w/ Three Notch Hold Open Clip - Atex	3.1 (1.4)
539632A	w/ Three Notch Hold Open Clip and Sightglass - Atex	3.1 (1.4)
E539616	w/ Three Notch Hold Open Clip and Mate Guard	3.1 (1.4)
E539687	w/ Three Notch Hold Open Clip Flo-Equalizer™ and Mate Guard	3.1 (1.4)
E539620	w/o Hold Open Clip w/ Mate Guard	3.1 (1.4)

New Light Duty Diesel Nozzles w/ BSPP Threads

MODEL NO.	DESCRIPTION	SHIPPING WEIGHT LBS (KG)
E359615	w/ Three Notch Hold Open Clip and Mate Guard	3.1 (1.4)
E539686	w/ Three Notch Hold Open Clip Flo-Equalizer™ and Mate Guard	3.1 (1.4)



CONSTRUCTION

Body	One piece die cast aluminum
Seals	Fluorocarbon
Packing	Double o-ring seal protected by fiber reinforced Teflon
Lever	One piece contoured steel with hard plastic cover
Inlet	3/4" / 19 mm NPTF

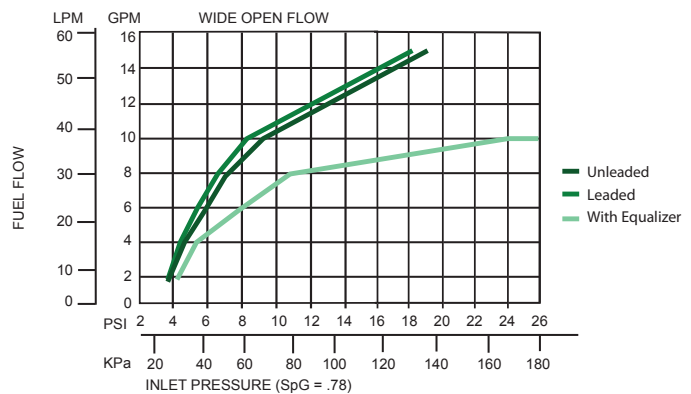

**Husky**

GENERAL FUELING PRODUCTS

XS**DP Nozzles****Pressure activated, automatic shut-off nozzle for full-service and self-service stations.**

Dimensions and System Options

Safe-T-Breaks®

MODEL NO.	DESCRIPTION
3360	¾" F x ¾" F NPTF Reconnectable Safe-T-Break®
2273	¾" F x ¾" F NPTF Non-Reconnectable Safe-T-Break®
6130	¾" F x ¾" F NPTF Non-Reconnectable PCC Safe-T-Break®
5230	¾" F x ¾" F NPTF Low Pull Reconnectable Safe-T-Break®
3385	¾" F x ¾" F BSPP Reconnectable Safe-T-Break®
2774	¾" F x ¾" F BSPP Non-Reconnectable Safe-T-Break®

Swivels

MODEL NO.	DESCRIPTION
0350	¾" M x ¾" F NPTF Multi-Plane Swivel
0355	¾" M x ¾" F NPTF Multi-Plane Swivel Anodized Black
0350W	¾" M x ¾" F NPTF Multi-Plane Swivel w/ Warm Weather Seals
2272	¾" M x ¾" F NPTF 90° Pump Swivel
3895	¾" M x ¾" F NPTF Inline Swivel
2950	¾" M x ¾" F NPTF Multi-Plane Restricted Swivel
3590	¾" M x ¾" F BSPP Multi-Plane Swivel
3590W	¾" M x ¾" F BSPP Multi-Plane Swivel w/ Warm Weather Seals
2771	¾" M x ¾" F BSPP 90° Pump Swivel

Swivel/Safe-T-Break® Combos

MODEL NO.	DESCRIPTION
6310	¾" M NPTF Multi-Plane Swivel connected to ¾" F NPTF Reconnectable Safe-T-Break®
7085	¾" M BSPP Multi-Plane Swivel connected to ¾" F BSPP Reconnectable Safe-T-Break®

Pressure/Vacuum Vents

MODEL NO.	DESCRIPTION
4620	2" Slip-On Pressure Vacuum Vent
4885	2" Thread-On Pressure Vacuum Vent - NPTF
5885	2" Thread-On Pressure Vacuum Vent with internal screen - NPTF

Accessories, Testing and Maintenance

MODEL NO.	DESCRIPTION
7089	Nozzle Service Kit
3593	Hold Open Clip Kit
0397	Unleaded Spout Gauge
4490	Conventional Flo-Equalizer™ - 10 gpm / 37.9 Lpm

Spouts

MODEL NO.	DESCRIPTION
1473	Unleaded Spout w/o Flo-Stop™
1471	Light Duty Diesel Spout w/o Flo-Stop™

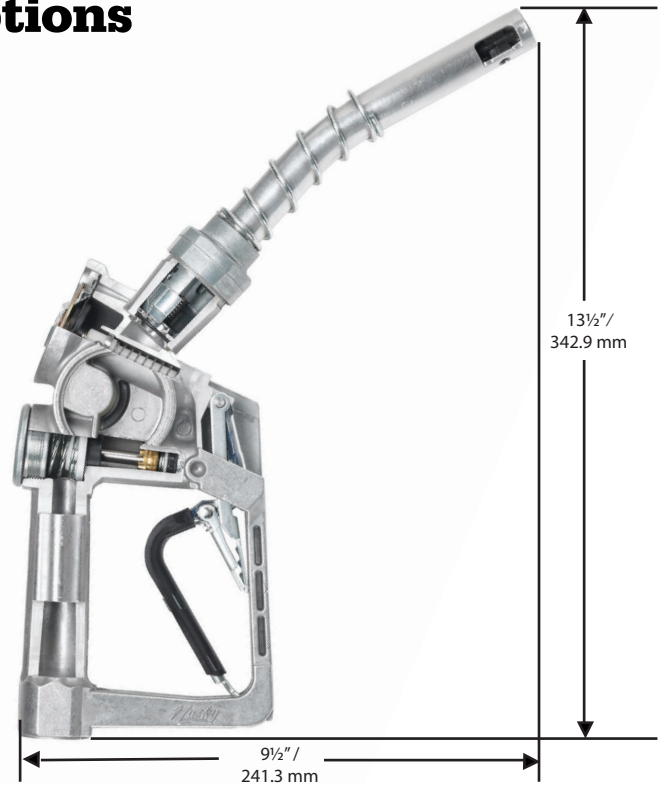

Guards

MODEL NO.	DESCRIPTION
4145	Full Grip Guard
6665	POPD™ S Full Grip Guard
8185	POPD™ H Full Grip Guard
1806	Full Grip Reguard
7205	POPD™ S Full Grip Reguard
8192	POPD™ H Full Grip Reguard
3795	Mate Guard
8165	POPD™ S Mate Guard
8166	POPD™ H Mate Guard
1808	Waffle Splash Guard
1506	Protection Package
1809	Reguard Protection Package
3440	Mate Easy-On Package
8175	POPD™ EZS Nozzle Guard
8176	POPD™ EZH Nozzle Guard
6628	POPD™ S Clear Cover
7999	POPD™ H Clear Cover
5494	Lever Guard
3376	Black Handle Cover



MADE IN THE U.S.A.



XS MFM Nozzles



Husky

GENERAL FUELING PRODUCTS

Pressure Activated, automatic shut-off nozzle for full-service and self-service stations.

- XS® Nozzle shuts off when
 - the pump shuts off.
 - the gas tank is full.
 - the lever is opened before the pump is turned on.
 - the leak detector has not completed the test cycle.
- StreamShaper™ reduces turbulence for straighter fuel flow and less splash back spillage.
- Comes standard with smooth full grip guard.
- Aluminum reinforced spout bushing keeps spout tip round and acts as a captive fastener to prevent tip-end sensor damage.
- Equipped with a unique Flo-Stop™ device that shuts off the nozzle if it falls from the fill tank or raises above the horizontal.



MODEL NO. DESCRIPTION SHIPPING WEIGHT LBS (KG)

New Unleaded Nozzles

159562	with Three Notch Hold Open Clip and Waffle Splash Guard	3.3 (1.4)
159568	without Hold Open Clip, with Red VSG, Sightglass and Lenticular Lens	3.0 (1.3)

New Light Duty Diesel Nozzles

159560	with Three Notch Hold Open Clip and Waffle Splash Guard	3.3 (1.4)
539660	with Three Notch Hold Open Clip, Double Poppet and Waffle Splash Guard	3.3 (1.4)

CONSTRUCTION

Body	One piece die cast aluminum
Seals	Fluorocarbon
Packing	Double o-ring seal protected by fiber reinforced Teflon
Lever	One piece contoured steel with hard plastic cover
Inlet	1" / 25.4 mm NPTF

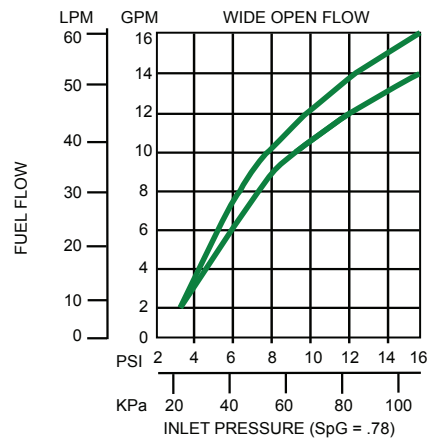

**Husky**

GENERAL FUELING PRODUCTS

XS MFM Nozzles

Pressure activated, automatic shut-off nozzle for full-service and self-service stations.

Dimensions and System Options

Safe-T-Breaks®

MODEL NO.	DESCRIPTION
2276	1" F x 1" F NPTF Reconnectable Safe-T-Break®
5812	1" F x 1" F NPTF Non-Reconnectable Safe-T-Break®
6301	1" F x 1" F NPTF Non-Reconnectable PCC Safe-T-Break®
5231	1" F x 1" F NPTF Low Pull Reconnectable Safe-T-Break®

Swivels

MODEL NO.	DESCRIPTION
0087	1" M x 1" F NPTF Multi-Plane Swivel
4860	1" M x 1" F NPTF Multi-Plane High Flow Swivel
0095	1" M x 1" F NPTF 70° Pump Swivel
3395	1" M x 1" F NPTF Multi-Plane Restricted Swivel
0352	1" M x 3/4" F NPTF Multi-Plane Swivel
0356	1" M x 3/4" F NPTF Multi-Plane Swivel Anodized Black

Swivel/Safe-T-Break® Combos

MODEL NO.	DESCRIPTION
5969	1" M NPTF Multi-Plane Swivel connected to 1" F NPTF Reconnectable Safe-T-Break®

Spouts

MODEL NO.	DESCRIPTION
1473	Unleaded Spout w/o Flo-Stop™
1471	Light Duty Diesel Spout w/o Flo-Stop™

Pressure/Vacuum Vents

MODEL NO.	DESCRIPTION
4620	2" Slip-On Pressure Vacuum Vent
4885	2" Thread-On Pressure Vacuum Vent - NPTF
5885	2" Thread-On Pressure Vacuum Vent with internal screen - NPTF

Accessories, Testing, and Maintenance

MODEL NO.	DESCRIPTION
7089	Nozzle Service Kit
3593	Hold Open Clip Kit
0397	Unleaded Spout Gauge
0385	1" M x 3/4" F Reducer Bushing

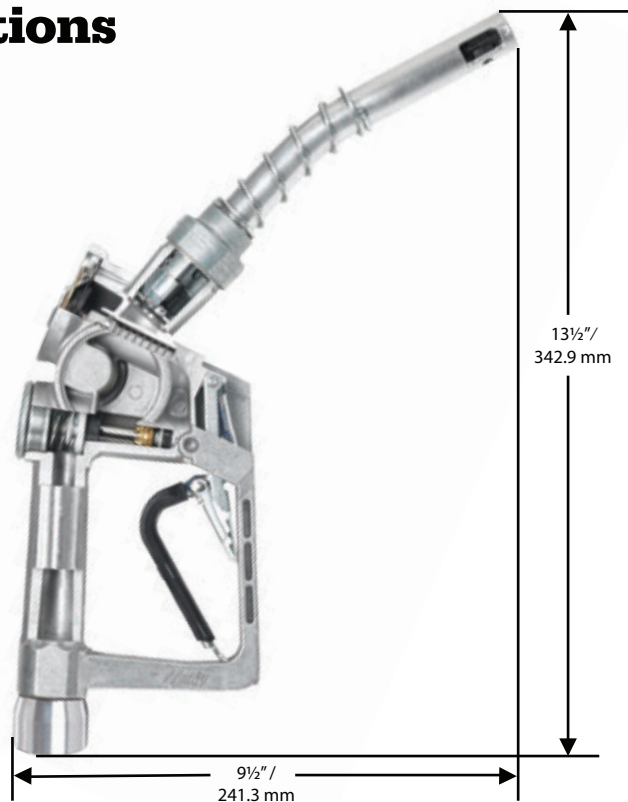

Guards

MODEL NO.	DESCRIPTION
4145	Full Grip Guard
6665	POPD™ S Full Grip Guard
8185	POPD™ H Full Grip Guard
1806	Full Grip Reguard
7205	POPD™ S Full Grip Reguard
8192	POPD™ H Full Grip Reguard
3795	Mate Guard
8165	POPD™ S Mate Guard
8166	POPD™ H Mate Guard
8175	POPD™ EZS Nozzle Guard
8176	POPD™ EZH Nozzle Guard
1808	Waffle Splash Guard
1506	Protection Package
1809	Reguard Protection Package
6628	POPD™ S Clear Cover
7999	POPD™ H Clear Cover
5494	Lever Guard



MADE IN THE U.S.A.



XS Rebuilt Nozzles



Pressure activated, automatic shut-off nozzle for full-service, self-service and unattended stations.

- XS® Nozzle shuts off when:
 - the pump shuts off.
 - the gas tank is full.
 - the lever is opened before the pump is turned on.
 - the leak detector has not completed the test cycle.
- Aluminum reinforced spout bushing keeps the spout tip round and acts as a captive fastener to prevent tip-end sensor damage.
- Nozzle is equipped with a unique Flo-Stop™ device that shuts off the nozzle if it falls from the fill tank or raises above the horizontal.
- *StreamShaper™* reduces turbulence for straighter fuel flow and less splash back spillage.
- Comes standard with smooth full grip guard.



Rebuilt Unleaded Nozzles

MODEL NO.	DESCRIPTION	SHIPPING WEIGHT LBS (KG)
265804	with Three Notch Hold Open Clip	3.1 (1.4)
265808	w/o Hold Open Clip	3.1 (1.4)
265824	with Three Notch Hold Open Clip and Sightglass	3.1 (1.4)
265844	with Three Notch Hold Open Clip, 1808 Waffle Splash Guard and Flo-Equalizer™	3.1 (1.4)
265854	with Three Notch Hold Open Clip and Flo-Equalizer™	3.1 (1.4)
265858	without Hold Open Clip, with Flo-Equalizer™	3.1 (1.4)
265864	with Three Notch Hold Open Clip and 1808 Waffle Splash Guard	3.0 (1.3)

Rebuilt Light Duty Diesel Nozzles

MODEL NO.	DESCRIPTION	SHIPPING WEIGHT LBS (KG)
265803	with Three Notch Hold Open Clip	3.1 (1.4)
265807	without Hold Open Clip with Three Notch Hold Open Clip, 1808 Waffle Splash Guard and Flo-Equalizer™	3.1 (1.4)
265845	with Three Notch Hold Open Clip and Flo-Equalizer™	3.1 (1.4)
265853	without Hold Open Clip, with Flo-Equalizer™	3.1 (1.4)
265857	with Three Notch Hold Open Clip and 1808 Waffle Splash Guard	3.3 (1.4)
265863	with Three Notch Hold Open Clip, Full Grip Guard and 1808 Waffle Splash Guard	3.1 (1.4)

Construction

Body	One piece die cast aluminum
Seals	Fluorocarbon
Packing	Double o-ring seal protected by fiber reinforced Teflon
Lever	One piece contoured steel
Inlet	¾" / 19 mm NPTF Threads

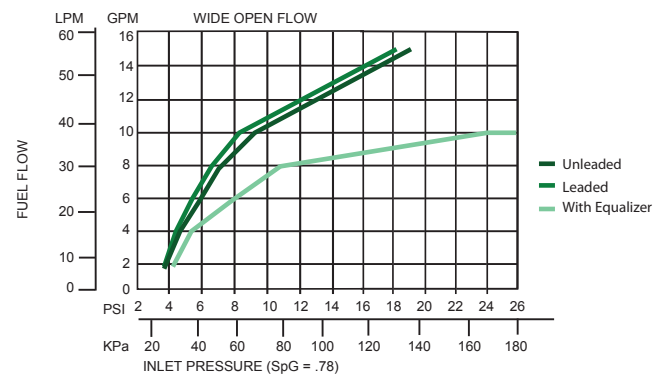

**Husky**

GENERAL FUELING PRODUCTS

XS Rebuilt Nozzles

Pressure activated, automatic shut-off nozzle for full-service, self-service and unattended stations.

Dimensions and System Options

Safe-T-Breaks®

MODEL NO.	DESCRIPTION
3360	¾" F x ¾" F NPTF Reconnectable Safe-T-Break®
2273	¾" F x ¾" F NPTF Non-Reconnectable Safe-T-Break®
6130	¾" F x ¾" F NPTF Non-Reconnectable PCC Safe-T-Break®
5230	¾" F x ¾" F NPTF Low Pull Reconnectable Safe-T-Break®

Swivels

MODEL NO.	DESCRIPTION
0350	¾" M x ¾" F NPTF Multi-plane Swivel
0350W	¾" M x ¾" F NPTF Multi-Plane Swivel w/ Warm Weather Seals
0355	¾" M x ¾" F NPTF Multi-plane Black Swivel
2272	¾" M x ¾" F NPTF 90° Pump Swivel
3895	¾" M x ¾" F NPTF Inline Swivel
2950	¾" M x ¾" F NPTF Multi-plane Restricted Swivel

Swivel/Safe-T-Break® Combos

MODEL NO.	DESCRIPTION
6310	¾" M NPTF Multi-plane Swivel connected to ¾" F NPTF Reconnectable Safe-T-Break®

Spouts

MODEL NO.	DESCRIPTION
1473	Unleaded Spout without Flo-Stop™
1471	Light Duty Diesel Spout without Flo-Stop™

Pressure/Vacuum Vents

MODEL NO.	DESCRIPTION
4620	2" Slip-On Pressure Vacuum Vent
4885	2" Thread-On Pressure Vacuum Vent - NPTF
5885	2" Thread-On Pressure Vacuum Vent with internal screen - NPTF

Accessories, Testing and Maintenance

MODEL NO.	DESCRIPTION
7089	Nozzle Service Kit
3593	Hold Open Clip Kit
0397	Unleaded Spout Gauge
4490	Conventional Flo-Equalizer™ - 10 gpm / 37.9 Lpm
7490	Internal Flo-Equalizer™ - 10 gpm / 37.9 Lpm

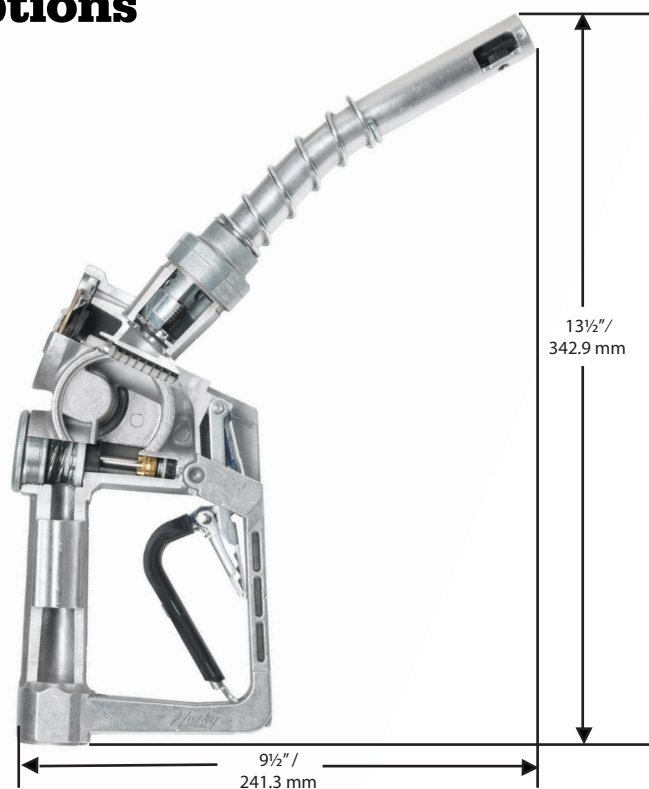

Guards

MODEL NO.	DESCRIPTION
4145	Full Grip Guard
6665	POPD™ S Full Grip Guard
8185	POPD™ H Full Grip Guard
1806	Full Grip Reguard
7205	POPD™ S Full Grip Reguard
8192	POPD™ H Full Grip Reguard
3795	Mate Guard
8165	POPD™ S Mate Guard
8166	POPD™ H Mate Guard
1808	Waffle Splash Guard
1506	Protection Package
1809	Reguard Protection Package
3440	Mate Easy-on Package
8175	POPD™ EZS Nozzle Guard
8176	POPD™ EZH Nozzle Guard
6628	POPD™ S Clear Cover
7999	POPD™ H Clear Cover
5494	Lever Guard
3376	Black Handle Cover



MADE IN THE U.S.A.



XS Sightglass Nozzles



Husky

GENERAL FUELING PRODUCTS

Automatic shut off nozzle for full-service and self-service stations.

- XS® nozzle shuts off when
 - the pump shuts off.
 - the gas tank is full.
 - the lever is opened before the pump is turned on.
 - the leak detector has not completed the test cycle.
- Stainless steel reinforced spout bushing keeps spout tip round and acts as a captive fastener to prevent tip-end sensor damage.
- Equipped with a unique Flo- Stop™ device that shuts off the nozzle if it falls from the fill tank or raises above the horizontal.
- Sightglass on nozzle allows customer to see fuel flow through nozzle.
- StreamShaper™ reduces turbulence for straighter fuel flow and less splash back spillage.
- Comes standard with smooth full grip guard.



New Unleaded Nozzles

MODEL NO.	DESCRIPTION	SHIPPING WEIGHT LBS (KG)
159524	w/ Three Notch Hold Open Clip	3.1 (1.4)
E159524	w/ Three Notch Hold Open Clip and Mate Guard	3.1 (1.4)
159528	without Hold Open Clip	3.1 (1.4)
E159528	without Hold Open Clip, with Mate Guard	3.1 (1.4)

New Light Duty Diesel Nozzles

MODEL NO.	DESCRIPTION	SHIPPING WEIGHT LBS (KG)
159523	w/ Three Notch Hold Open Clip	3.1 (1.4)
E159523	w/ Three Notch Hold Open Clip w/ Mate Guard	3.1 (1.4)
159527	without Hold Open Clip	3.1 (1.4)
E159527	without Hold Open Clip w/ Mate Guard	3.1 (1.4)

Construction

Body	One piece die cast aluminum
Seals	Fluorocarbon
Packing	Double o-ring seal protected by fiber reinforced Teflon
Lever	One piece contoured steel with hard plastic cover
Inlet	3/4" / 19.1 mm NPTF

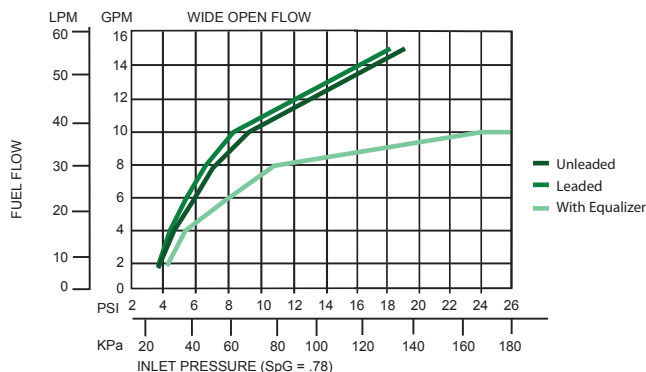

**Husky**

GENERAL FUELING PRODUCTS



Sightglass Nozzles

Automatic shut off nozzle for full-service and self-service stations.

Dimensions and System Options

Safe-T-Breaks®

MODEL NO.	DESCRIPTION
3360	¾" F x ¾" F NPTF Reconnectable Safe-T-Break®
2273	¾" F x ¾" F NPTF Non-Reconnectable Safe-T-Break®
6130	¾" F x ¾" F NPTF Non-Reconnectable PCC Safe-T-Break®
5230	¾" F x ¾" F NPTF Low Pull Reconnectable Safe-T-Break®

Swivels

MODEL NO.	DESCRIPTION
0350	¾" M x ¾" F NPTF Multi-Plane Swivel
0350W	¾" M x ¾" F NPTF Multi-Plane Swivel with Warm Weather Seals
0355	¾" M x ¾" F NPTF Multi-Plane Swivel Anodized Black
2272	¾" M x ¾" F NPTF 90° Pump Swivel
3895	¾" M x ¾" F NPTF Inline Swivel
2950	¾" M x ¾" F NPTF Multi-Plane Restricted Swivel

Swivel/Safe-T-Break® Combos

MODEL NO.	DESCRIPTION
6310	¾" M NPTF Multi-Plane Swivel connected to ¾" F NPTF Reconnectable Safe-T-Break®

Spouts

MODEL NO.	DESCRIPTION
1473	Unleaded Spout without Flo-Stop™
1471	Light Duty Diesel Spout without Flo-Stop™

Pressure/Vacuum Vents

MODEL NO.	DESCRIPTION
4620	2" Slip-On Pressure Vacuum Vent
4885	2" Thread-On Pressure Vacuum Vent - NPTF
5885	2" Thread-On Pressure Vacuum Vent with internal screen - NPTF

Accessories, Testing and Maintenance

MODEL NO.	DESCRIPTION
7089	Nozzle Service Kit
3593	Hold Open Clip Kit
0397	Unleaded Spout Gauge
4490	Conventional Flo-Equalizer™ - 10 gpm / 37.9 Lpm
7490	Internal Flo-Equalizer™ - 10 gpm / 37.9 Lpm

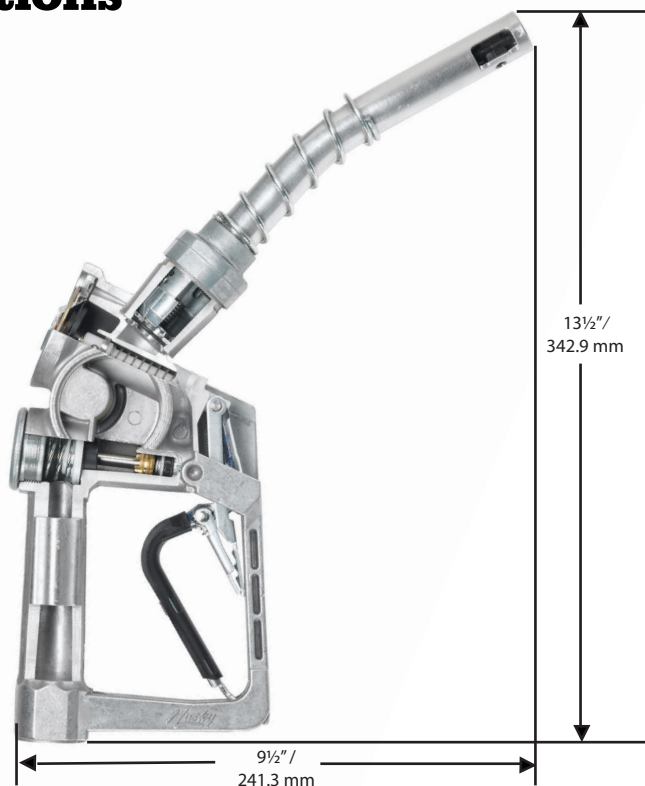

Guards

MODEL NO.	DESCRIPTION
4145	Full Grip Guard
6665	POPD™ S Full Grip Guard
8185	POPD™ H Full Grip Guard
1806	Full Grip Reguard
7205	POPD™ S Full Grip Reguard
8192	POPD™ H Full Grip Reguard
3795	Mate Guard
8165	POPD™ S Mate Guard
8166	POPD™ H Mate Guard
8175	POPD™ EZS Nozzle Guard
8176	POPD™ EZH Nozzle Guard
1808	Waffle Splash Guard
1506	Protection Package
1809	Reguard Protection Package
3440	Mate Easy-on Package
6628	POPD™ S Clear Cover
8181	POPD™ H Clear Cover
5494	Lever Guard
3376	Black Handle Guard



MADE IN THE U.S.A.





Husky

GENERAL FUELING PRODUCTS

Farm & Commercial Nozzles

1GS Nozzles



Automatic shut-off nozzle for farm, 12V skid tanks, large pumps with or without air eliminators and commercial applications.

- 1GS nozzle shuts off when the gas tank is full.
- Equipped with unique Flo-Stop™ device that shuts off the nozzle if it falls from the fill tank or raises above the horizontal.
- Not for use with gravity tanks.
- Heavy duty, long lasting metal hand guard.
- Not legal for retail dispensing applications.

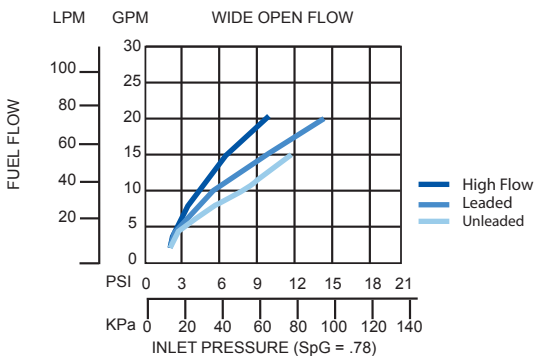

Unleaded Nozzles w/ NPTF Threads

MODEL NO.	DESCRIPTION	SHIPPING WEIGHT LBS (KG)
696204	New with Three Notch Hold Open Clip, Full Grip Guard and Hook	3.6 (1.6)
696208	New without Hold Open Clip with Full Grip Guard and Hook	3.6 (1.6)
696259	New with Three Notch Hold Open Clip, Full Grip Guard, Hook and Reducer Bushing	3.6 (1.6)
696504	Rebuilt with Three Notch Hold Open Clip, Full Grip Guard and Hook	3.6 (1.6)
696559	Rebuilt with Three Notch Hold Open Clip, Full Grip Guard, Hook and Reducer Bushing	3.6 (1.6)

Unleaded Nozzles w/ BSPP Threads

MODEL NO.	DESCRIPTION	SHIPPING WEIGHT LBS (KG)
696216	New with Three Notch Hold Open Clip, Full Grip Guard and Hook	3.6 (1.6)

Light Duty Diesel Nozzles w/ NPTF Threads

MODEL NO.	DESCRIPTION	SHIPPING WEIGHT LBS (KG)
696203	New with Three Notch Hold Open Clip, Full Grip Guard and Hook	3.6 (1.6)
696207	New without Hold Open Clip with Full Grip Guard and Hook	3.6 (1.6)
696261	New with Three Notch Hold Open Clip, Full Grip Guard, Hook and Reducer Bushing	3.6 (1.6)
696503	Rebuilt with Three Notch Hold Open Clip, Full Grip Guard and Hook	3.6 (1.6)
696561	Rebuilt with Three Notch Hold Open Clip, Full Grip Guard, Hook and Reducer Bushing	3.6 (1.6)

Light Duty Diesel Nozzles w/ BSPP Threads

MODEL NO.	DESCRIPTION	SHIPPING WEIGHT LBS (KG)
696215	New with Three Notch Hold Open Clip, Full Grip Guard and Hook	3.6 (1.6)

Heavy Duty Diesel Nozzles w/ NPTF Threads

MODEL NO.	DESCRIPTION	SHIPPING WEIGHT LBS (KG)
696210	New with Three Notch Hold Open Clip, Full Grip Guard and Hook	3.6 (1.6)
696510	Rebuilt with Three Notch Hold Open Clip, Full Grip Guard and Hook	3.6 (1.6)

Heavy Duty Diesel Nozzles w/ BSPP Threads

MODEL NO.	DESCRIPTION	SHIPPING WEIGHT LBS (KG)
696238	New with Three Notch Hold Open Clip, Full Grip Guard and Hook	3.6 (1.6)

Construction

Body	Aluminum
Seals	Fluorocarbon
Packing	Double o-ring seal protected by fiber reinforced Teflon
Lever	One piece contoured steel with hard plastic cover
Inlet	1" / 25.4 mm NPTF & BSPP



Automatic shut-off nozzle for farm, 12V skid tanks, large pumps with or without air eliminators and commercial applications.

Dimensions and System Options

Safe-T-Breaks®

MODEL NO.	DESCRIPTION
2276	1" F x 1" F NPTF Reconnectable Safe-T-Break®
5812	1" F x 1" F NPTF Non-Reconnectable Safe-T-Break®
6301	1" F x 1" F NPTF Non-Reconnectable PCC Safe-T-Break®
5231	1" F x 1" F NPTF Low Pull Reconnectable Safe-T-Break®
3076	1" F x 1" F BSPP Reconnectable Safe-T-Break®
3076A	1" F x 1" F BSPP Reconnectable Safe-T-Break® - Atex
6914	1" F x 1" F BSPP Non-Reconnectable Safe-T-Break®

Swivels

MODEL NO.	DESCRIPTION
0087	1" M x 1" F NPTF Multi-Plane Swivel
0087W	1" M x 1" F NPTF Multi-Plane Swivel w/ Warm Weather Seals
0095	1" M x 1" F NPTF 70° Pump Swivel
3395	1" M x 1" F NPTF Multi-Plane Restricted Swivel
0352	1" M x 3/4" F NPTF Multi-Plane Swivel
0356	1" M x 3/4" F NPTF Multi-Plane Swivel Anodized Black
3306	1" M x 1" F BSPP Multi-Plane Swivel
3306W	1" M x 1" F BSPP Multi-Plane Swivel w/ Warm Weather Seals

Swivel•Safe-T-Break® Combos

MODEL NO.	DESCRIPTION
5969	1" M NPTF Multi-Plane Swivel connected to 1" F NPTF Reconnectable Safe-T-Break®
8015	1" M BSPP Multi-Plane Swivel connected to 1" F BSPP Reconnectable Safe-T-Break®

Spouts

MODEL NO.	DESCRIPTION
1473	Unleaded Spout w/o Flo-Stop™
1471	Light Duty Diesel Spout w/o Flo-Stop™
5215	Heavy Duty Diesel Spout with Flo-Stop™

Pressure/Vacuum Vents

MODEL NO.	DESCRIPTION
4620	2" Slip-On Pressure Vacuum Vent
4885	2" Thread-On Pressure Vacuum Vent - NPTF
5885	2" Thread-On Pressure Vacuum Vent with internal screen - NPTF

Accessories, Testing and Maintenance

MODEL NO.	DESCRIPTION
7089	Nozzle Service Kit
3593	Hold Open Clip Kit
0385	1" M x 3/4" F Reducer Bushing - NPTF Threads
1717	1" M x 3/4" F Reducer Bushing - BSPP Threads
0397	Unleaded Spout Gauge
0548	Hanging Hook for Unleaded and Light Duty Diesel Nozzles

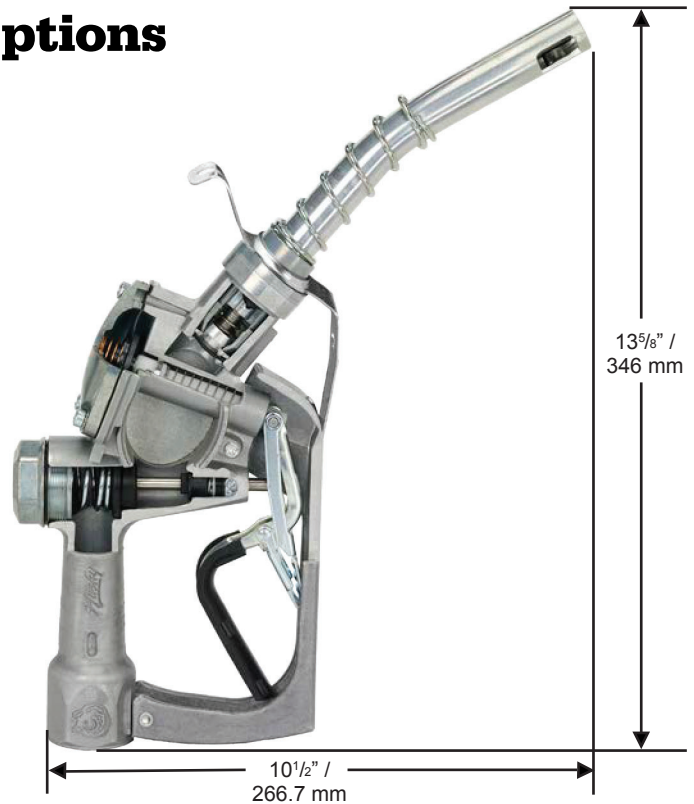

Guards

MODEL NO.	DESCRIPTION
0554	Full Grip Guard
6655	POPD™ S Full Grip Guard
8183	POPD™ H Full Grip Guard
1804	Full Grip Reguard
7210	POPD™ S Full Grip Reguard
8190	POPD™ H Full Grip Reguard
0226	Mate Guard
8169	POPD™ S Mate Guard
8170	POPD™ H Mate Guard
8179	POPD™ EZS Nozzle Guard
8180	POPD™ EZH Nozzle Guard
6628	POPD™ S Clear Cover
7999	POPD™ H Clear Cover
5494	Lever Guard
7376	Mate Handle Guard

1GS Nozzles



Automatic shut-off nozzle for farm, 12V skid tanks, large pumps with or without air eliminators and commercial applications.

- 1GS nozzle shuts off when the gas tank is full.
- Equipped with unique Flo-Stop™ device that shuts off the nozzle if it falls from the fill tank or raises above the horizontal.
- Not for use with gravity tanks.
- Not legal for retail dispensing applications.



New Unleaded Nozzles w/ NPTF Threads

MODEL NO.	DESCRIPTION	SHIPPING WEIGHT LBS (KG)
045704	with Three Notch Hold Open Clip, Full Grip Guard and Hook	3.6 (1.6)
045708	without Hold Open Clip with Full Grip Guard and Hook	3.6 (1.6)
045759	with Three Notch Hold Open Clip, Full Grip Guard, Hook and Reducer Bushing	3.6 (1.6)

New Unleaded Nozzles w/ BSPP Threads

MODEL NO.	DESCRIPTION	SHIPPING WEIGHT LBS (KG)
045716	with Three Notch Hold Open Clip, Full Grip Guard and Hook	3.6 (1.6)
045720	without Hold Open Clip with Full Grip Guard and Hook	3.6 (1.6)

New Light Duty Diesel Nozzles w/ NPTF Threads

MODEL NO.	DESCRIPTION	SHIPPING WEIGHT LBS (KG)
045703	with Three Notch Hold Open Clip, Full Grip Guard and Hook	3.6 (1.6)
045707	without Hold Open Clip with Full Grip Guard and Hook	3.6 (1.6)
045761	with Three Notch Hold Open Clip, Full Grip Guard, Hook and Reducer Bushing	3.6 (1.6)

New Light Duty Diesel Nozzles w/ BSPP Threads

MODEL NO.	DESCRIPTION	SHIPPING WEIGHT LBS (KG)
045715	with Three Notch Hold Open Clip, Full Grip Guard and Hook	3.6 (1.6)
045719	without Hold Open Clip with Full Grip Guard and Hook	3.6 (1.6)

New Heavy Duty Diesel Nozzles w/ NPTF Threads

MODEL NO.	DESCRIPTION	SHIPPING WEIGHT LBS (KG)
045709	with Three Notch Hold Open Clip, Full Grip Guard and Hook without Flo-Stop™	3.6 (1.6)
045710	with Three Notch Hold Open Clip, with Full Grip Guard, and Hanging Hook	3.6 (1.6)

New Heavy Duty Diesel Nozzles w/ BSPP Threads

MODEL NO.	DESCRIPTION	SHIPPING WEIGHT LBS (KG)
045738	with Three Notch Hold Open Clip, Full Grip Guard and Hook	3.6 (1.6)

Construction

Body	Aluminum
Seals	Fluorocarbon
Packing	Double o-ring seal protected by fiber reinforced Teflon
Lever	One piece contoured steel with hard plastic cover
Inlet	1" / 25.4 mm NPTF

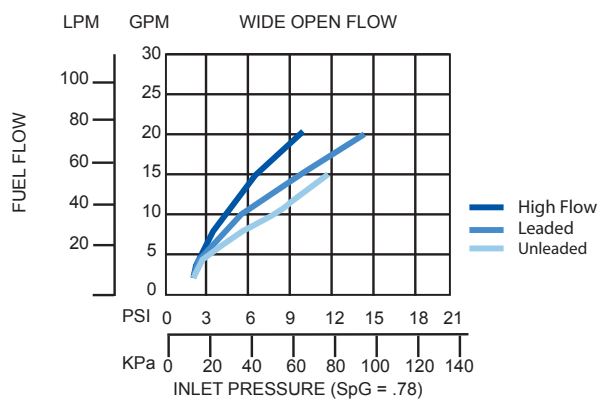

Automatic shut-off nozzle for farm, 12V skid tanks, large pumps with or without air eliminators and commercial applications.

Dimensions and System Options

Safe-T-Breaks®

MODEL NO.	DESCRIPTION
2276	1" F x 1" F NPTF Reconnectable Safe-T-Break®
5812	1" F x 1" F NPTF Non-Reconnectable Safe-T-Break®
6301	1" F x 1" F NPTF Non-Reconnectable PCC Safe-T-Break®
5231	1" F x 1" F NPTF Low Pull Reconnectable Safe-T-Break®
3076	1" F x 1" F BSPP Reconnectable Safe-T-Break®
3076A	1" F x 1" F BSPP Reconnectable Safe-T-Break® - Atex
6914	1" F x 1" F BSPP Non-Reconnectable Safe-T-Break®

Swivels

MODEL NO.	DESCRIPTION
0087	1" M x 1" F NPTF Multi-Plane Swivel
0087W	1" M x 1" F NPTF Multi-Plane Swivel w/ Warm Weather Seals
0095	1" M x 1" F NPTF 70° Pump Swivel
3395	1" M x 1" F NPTF Multi-Plane Restricted Swivel
0352	1" M x 3/4" F NPTF Multi-Plane Swivel
0356	1" M x 3/4" F NPTF Multi-Plane Swivel Anodized Black
3306	1" M x 1" F BSPP Multi-Plane Swivel
3306W	1" M x 1" F BSPP Multi-Plane Swivel w/ Warm Weather Seals

Swivel•Safe-T-Break® Combos

MODEL NO.	DESCRIPTION
5969	1" M NPTF Multi-Plane Swivel connected to 1" F NPTF Reconnectable Safe-T-Break®
8015	1" M BSPP Multi-Plane Swivel connected to 1" F BSPP Reconnectable Safe-T-Break®

Spouts

MODEL NO.	DESCRIPTION
1473	Unleaded Spout w/o Flo-Stop™
1471	Light Duty Diesel Spout w/o Flo-Stop™
5215	Heavy Duty Diesel Spout with Flo-Stop™

Pressure/Vacuum Vents

MODEL NO.	DESCRIPTION
4620	2" Slip-On Pressure Vacuum Vent
4885	2" Thread-On Pressure Vacuum Vent - NPTF
5885	2" Thread-On Pressure Vacuum Vent with internal screen - NPTF

Accessories, Testing and Maintenance

MODEL NO.	DESCRIPTION
7089	Nozzle Service Kit
3593	Hold Open Clip Kit
0385	1" M x 3/4" F Reducer Bushing - NPTF Threads
1717	1" M x 3/4" F Reducer Bushing - BSPP Threads
0397	Unleaded Spout Gauge
0548	Hanging Hook for Unleaded and Light Duty Diesel Nozzles

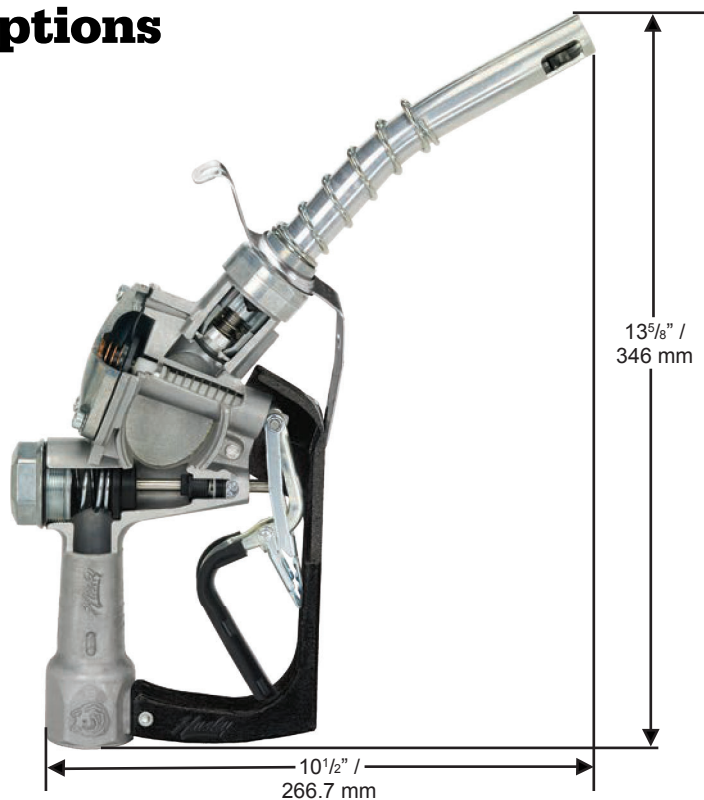

Guards

MODEL NO.	DESCRIPTION
0554	Full Grip Guard
6655	POPD™ S Full Grip Guard
8183	POPD™ H Full Grip Guard
1804	Full Grip Reguard
7210	POPD™ S Full Grip Reguard
8190	POPD™ H Full Grip Reguard
0226	Mate Guard
8169	POPD™ S Mate Guard
8170	POPD™ H Mate Guard
8179	POPD™ EZS Nozzle Guard
8180	POPD™ EZH Nozzle Guard
6628	POPD™ S Clear Cover
7999	POPD™ H Clear Cover
5494	Lever Guard
7376	Mate Handle Guard

1GS Nozzles



Automatic shut-off nozzle for farm, 12V skid tanks, large pumps with or without air eliminators and commercial applications.

- 1GS nozzle shuts off when the gas tank is full.
- Equipped with unique Flo-Stop™ device that shuts off the nozzle if it falls from the fill tank or raises above the horizontal.
- Not for use with gravity tanks.
- Not legal for retail dispensing applications.



Rebuilt Unleaded Nozzles

MODEL NO.	DESCRIPTION	SHIPPING WEIGHT LBS (KG)
078604	with Three Notch Hold Open Clip, Full Grip Guard and Hook	3.6 (1.6)
078659	with Three Notch Hold Open Clip, Full Grip Guard, Hook and Reducer Bushing	3.6 (1.6)

Rebuilt Light Duty Diesel Nozzles

MODEL NO.	DESCRIPTION	SHIPPING WEIGHT LBS (KG)
078603	with Three Notch Hold Open Clip, Full Grip Guard and Hook	3.6 (1.6)
078661	with Three Notch Hold Open Clip, Full Grip Guard, Hook and Reducer Bushing	3.6 (1.6)

Rebuilt Heavy Duty Diesel Nozzles

MODEL NO.	DESCRIPTION	SHIPPING WEIGHT LBS (KG)
078610	with Three Notch Hold Open Clip, Full Grip Guard and Hook	3.6 (1.6)

CONSTRUCTION

Body	Die cast aluminum body with black hand guard
Seals	Fluorocarbon
Packing	Double o-ring seal protected by fiber reinforced Teflon
Lever	One piece contoured steel with hard plastic cover
Inlet	1" / 25.4 mm NPTF

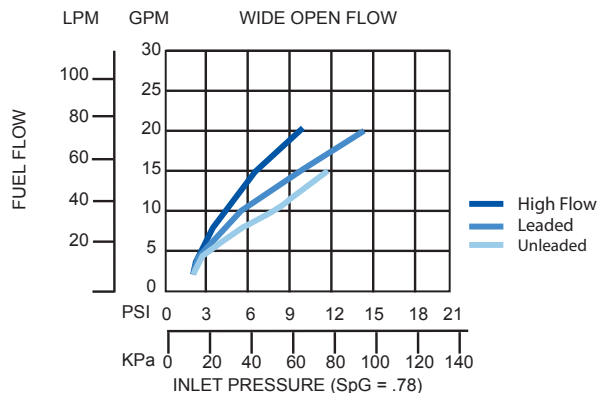

Automatic shut-off nozzle for farm, 12V skid tanks, large pumps with or without air eliminators and commercial applications.

Dimensions and System Options

Safe-T-Breaks®

MODEL NO.	DESCRIPTION
2276	1" F x 1" F NPTF Reconnectable Safe-T-Break®
5812	1" F x 1" F NPTF Non-Reconnectable Safe-T-Break®
6301	1" F x 1" F NPTF Non-Reconnectable PCC Safe-T-Break®
5231	1" F x 1" F NPTF Low Pull Reconnectable Safe-T-Break®

Swivels

MODEL NO.	DESCRIPTION
0087	1" M x 1" F NPTF Multi-Plane Swivel
0087W	1" M x 1" F NPTF Multi-Plane Swivel w/ Warm Weather Seals
0095	1" M x 1" F NPTF 70° Pump Swivel
3395	1" M x 1" F NPTF Multi-Plane Restricted Swivel
0352	1" M x 3/4" F NPTF Multi-Plane Swivel
0356	1" M x 3/4" F NPTF Multi-Plane Swivel Anodized Black

Swivel•Safe-T-Break® Combos

MODEL NO.	DESCRIPTION
5969	1" M NPTF Multi-Plane Swivel connected to 1" F NPTF Reconnectable Safe-T-Break®

Spouts

MODEL NO.	DESCRIPTION
1473	Unleaded Spout w/o Flo-Stop™
1471	Light Duty Diesel Spout w/o Flo-Stop™
5215	Heavy Duty Diesel Spout with Flo-Stop™

Pressure/Vacuum Vents

MODEL NO.	DESCRIPTION
4620	2" Slip-On Pressure Vacuum Vent
4885	2" Thread-On Pressure Vacuum Vent - NPTF
5885	2" Thread-On Pressure Vacuum Vent with internal screen - NPTF

Accessories, Testing and Maintenance

MODEL NO.	DESCRIPTION
7089	Nozzle Service Kit
3593	Hold Open Clip Kit
0385	1" M x 3/4" F Reducer Bushing - NPTF Threads
0397	Unleaded Spout Gauge
0548	Hanging Hook for Unleaded and Light Duty Diesel Nozzles

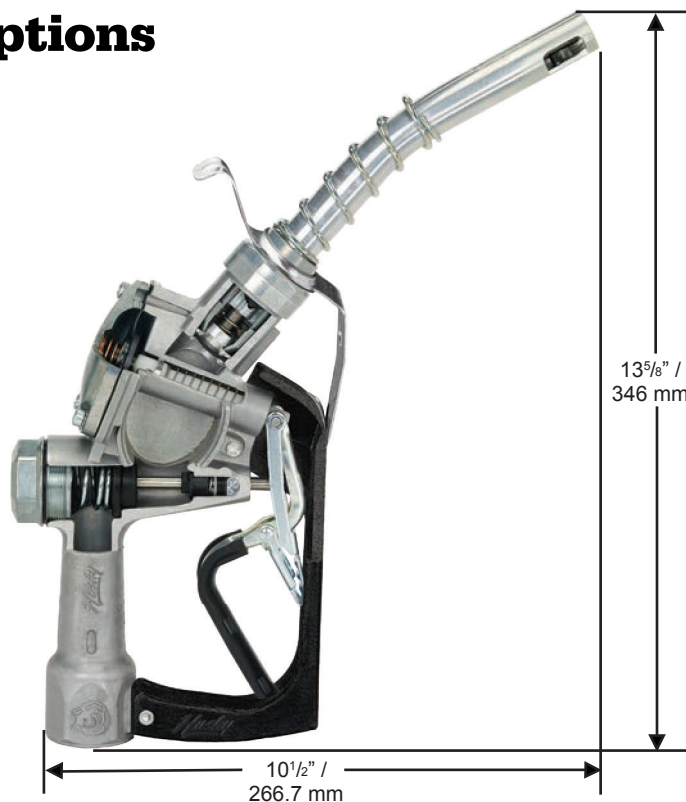

Guards

MODEL NO.	DESCRIPTION
0554	Full Grip Guard
6655	POPD™ S Full Grip Guard
8183	POPD™ H Full Grip Guard
1804	Full Grip Reguard
7210	POPD™ S Full Grip Reguard
8190	POPD™ H Full Grip Reguard
0226	Mate Guard
8169	POPD™ S Mate Guard
8170	POPD™ H Mate Guard
8179	POPD™ EZS Nozzle Guard
8180	POPD™ EZH Nozzle Guard
6628	POPD™ S Clear Cover
7999	POPD™ H Clear Cover
5494	Lever Guard
7376	Mate Handle Guard

Automatic shut-off nozzle for farm, 12V skid tanks and consumer pump applications.

- Strong, improved flow - up to 18 gpm / 68.1 Lpm.
- Dispenses 10 gpm / 37.8 Lpm at only 5.6 psi / 0.38 bar (unleaded nozzle).
- Nozzle is equipped with a unique Flo-Stop™ device that shuts off the nozzle if it falls from the fill tank or is raised above horizontal.
- Unleaded nozzle includes StreamShaper™ to reduce turbulence for straighter fuel flow and less splash back spillage.
- Has built-in hook and fits “holster lock” of skid tank pumps.
- Not for use with gravity tanks.
- Not legal for retail dispensing applications.



Unleaded Nozzles - NPTF Threads

MODEL NO.	DESCRIPTION	SHIPPING WEIGHT LBS (KG)
337004	New with Three Notch Hold Open Clip, Full Grip Guard and Hook	3.0 (1.3)
337008	New without Hold Open Clip, with Full Grip Guard and Hook	3.0 (1.3)
503404	New with Three Notch Hold Open Clip and Full Grip Guard, without Hook	3.0 (1.3)
504304	Rebuilt with Three Notch Hold Open Clip, Full Grip Guard and Hook	3.1 (1.4)
503604	Rebuilt with Three Notch Hold Open Clip and Full Grip Guard, without Hook	3.1 (1.4)

Unleaded Nozzles - BSPP Threads

MODEL NO.	DESCRIPTION	SHIPPING WEIGHT LBS (KG)
337016	New with Three Notch Hold Open Clip, Full Grip Guard and Hook	3.0 (1.3)
503416	New with Three Notch Hold Open Clip and Full Grip Guard, without Hook	2.9 (1.3)

Light Duty Diesel Nozzles - NPTF Threads

MODEL NO.	DESCRIPTION	SHIPPING WEIGHT LBS (KG)
337003	New with Three Notch Hold Open Clip, Full Grip Guard and Hook	3.2 (1.4)
337007	New without Hold Open Clip, with Full Grip Guard and Hook	3.2 (1.4)
503403	New with Three Notch Hold Open Clip and Full Grip Guard, without Hook	3.6 (1.6)
504303	Rebuilt with Three Notch Hold Open Clip, Full Grip Guard and Hook	3.2 (1.4)
503603	Rebuilt with Three Notch Hold Open Clip and Full Grip Guard, without Hook	3.2 (1.4)

Light Duty Diesel Nozzles - BSPP Threads

MODEL NO.	DESCRIPTION	SHIPPING WEIGHT LBS (KG)
337015	New with Three Notch Hold Open Clip, Full Grip Guard and Hook	2.9 (1.3)
503415	New with Three Notch Hold Open Clip and Full Grip Guard, without Hook	2.9 (1.3)

Construction

Body	Aluminum
Seals	Fluorocarbon
Packing	Double o-ring seal protected by fiber reinforced Teflon
Lever	One piece contoured steel with hard plastic cover
Inlet	¾" / 19 mm NPTF & BSP

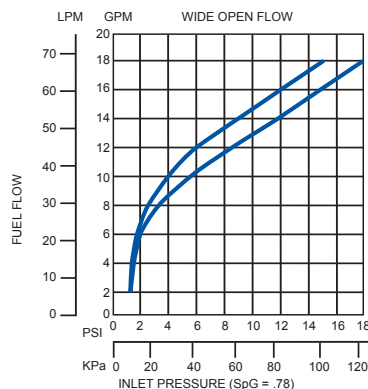

**Husky**

GENERAL FUELING PRODUCTS

XFS Nozzles

Automatic shut-off nozzle for farm, 12V skid tanks and consumer pump applications.

Dimensions and System Options

Safe-T-Breaks®

MODEL NO.	DESCRIPTION
3360	¾" F x ¾" F NPTF Reconnectable Safe-T-Break®
2273	¾" F x ¾" F NPTF Non-Reconnectable Safe-T-Break®
6130	¾" F x ¾" F NPTF Non-Reconnectable PCC Safe-T-Break®
5230	¾" F x ¾" F NPTF Low Pull Reconnectable Safe-T-Break®
3385	¾" F x ¾" F BSPP Reconnectable Safe-T-Break®
2774	¾" F x ¾" F BSPP Non-Reconnectable Safe-T-Break®

Swivels

MODEL NO.	DESCRIPTION
0350	¾" M x ¾" F NPTF Multi-Plane Swivel
0350W	¾" M x ¾" F NPTF Multi-Plane Swivel w/ Warm Weather Seals
0355	¾" M x ¾" F NPTF Multi-Plane Swivel Anodized Black
3895	¾" M x ¾" F NPTF Inline Swivel
2272	¾" M x ¾" F NPTF 90° Pump Swivel
2950	¾" M x ¾" F NPTF Multi-Plane Restricted Swivel
3590	¾" M x ¾" F BSPP Multi-Plane Swivel
3590W	¾" M x ¾" F BSPP Multi-Plane Swivel w/ Warm Weather Seals
2771	¾" M x ¾" F BSPP 90° Pump Swivel

Swivel•Safe-T-Break® Combos

MODEL NO.	DESCRIPTION
6310	¾" M NPTF Multi-Plane Swivel connected to ¾" F NPTF Reconnectable Safe-T-Break®
7085	¾" M BSPP Multi-Plane Swivel connected to ¾" F BSPP Reconnectable Safe-T-Break®

Spouts

MODEL NO.	DESCRIPTION
3356	Unleaded Spout with Hanging Hook without Flo-Stop™
1473	Unleaded Spout without Hanging Hook and Flo-Stop™
3358	Light Duty Diesel with Hanging Hook without Flo-Stop™
1471	Light Duty Diesel Spout without Hanging Hook and Flo-Stop™

Accessories, Testing and Maintenance

MODEL NO.	DESCRIPTION
7089	Nozzle Service Kit
3593	Hold Open Clip Kit
0397	Unleaded Spout Gauge

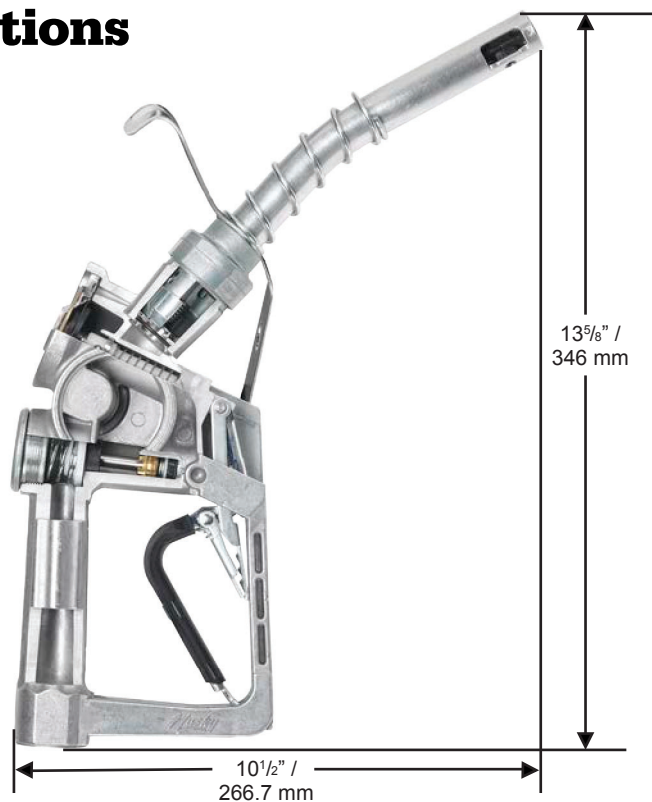

Guards

MODEL NO.	DESCRIPTION
4145	Full Grip Guard
6665	POPD™ S Full Grip Guard
8185	POPD™ H Full Grip Guard
1806	Full Grip Reguard
7205	POPD™ S Full Grip Reguard
8192	POPD™ H Full Grip Reguard
3795	Mate Guard
8165	POPD™ S Mate Guard
8166	POPD™ H Mate Guard
3440	Easy-On Mate Package
8175	POPD™ EZS Nozzle Guard
8176	POPD™ EZH Nozzle Guard
6628	POPD™ S Clear Cover
7999	POPD™ H Clear Cover
5494	Lever Guard



MADE IN THE U.S.A.





Husky

GENERAL FUELING PRODUCTS

Diesel Exhaust Fluid Nozzles

DEF Nozzles



Automatic shut off Diesel Exhaust Fluid (DEF) nozzle for full-service and self-service stations.

- Modular design for easy cleaning.
- Equipped with a unique Flo-Stop™ device that shuts off the nozzle if it falls from the fill tank or raises above the horizontal.
- Constructed from materials 100% compatible with Diesel Exhaust Fluid (DEF).
- Comes standard with mate nozzle guard and fluted handle cover.
- Nozzle shuts off when the DEF tank is full.
- Available with magnetic Accufuel™ safety feature.
- Stainless Steel construction.

DEF Nozzles

MODEL NO.	DESCRIPTION	SHIPPING WEIGHT LBS (KG)
731004	with Two Notch Hold Open Clip; without Spout Ring and magnetic Accufuel™ Spout	4.6 (2.1)
731088	with Two Notch Hold Open Clip and Spout Ring; without magnetic Accufuel™ Spout	4.6 (2.1)
731091	with Two Notch Hold Open Clip, Spout Ring and magnetic Accufuel™ Spout	4.6 (2.1)

Construction

Body	Investment Cast Stainless Steel
Seals	Fluorocarbon
Packing	Double o-ring seal protected by fiber reinforced Teflon
Lever	One piece contoured steel with hard plastic cover
Inlet	1" / 25.4 mm BSPP

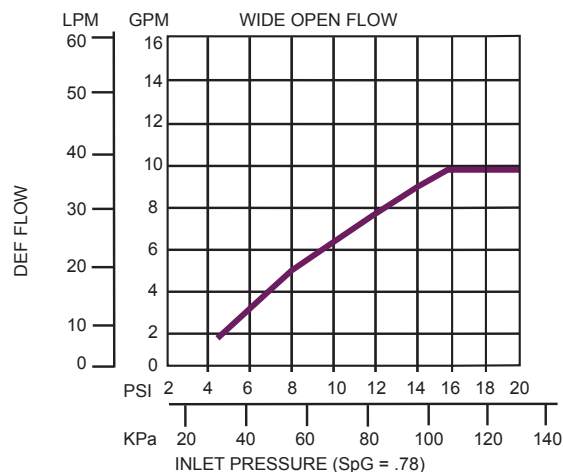

Automatic shut off Diesel Exhaust Fluid (DEF) nozzle for full-service and self-service stations.

Dimensions and System Options

Safe-T-Breaks®

MODEL NO.	DESCRIPTION
7219	1" M x 1" M BSPP Non-Reconnectable Stainless Steel Safe-T-Break®
7204	1" M x 1" M BSPP Non-Reconnectable HDPE Safe-T-Break®

Swivel

MODEL NO.	DESCRIPTION
7269	1" M x 1" M BSPP Inline Swivel

Spouts

MODEL NO.	DESCRIPTION
7360	with Spout Ring; without Magnetic Accufuel™ safety feature
7364	with Spout Ring and Magnetic Accufuel™ safety feature
7362	without Spout Ring and Magnetic Accufuel™ safety feature

Guards

MODEL NO.	DESCRIPTION
0226	Mate Nozzle Guard
7376	Handle Cover (Black)
1808	Waffle Splash Guard
8429	DEF Hand Guard Repair Kit

Adaptors

MODEL NO.	DESCRIPTION
7285	1" M x 1" M BSPP Straight Adaptor
7356	1" M BSPP x M M34 Straight Adaptor
8529	1" F x 3/4" M Adaptor (NPTF threads)

Accessories, Testing and Maintenance

MODEL NO.	DESCRIPTION
7523	1" BSPP Seal Kit Assembly
7150	Poppet Valve / Venturi Cartridge Assembly
7160	Plunger Cartridge Assembly
7163	Loss Motion Diaphragm Cartridge Assembly

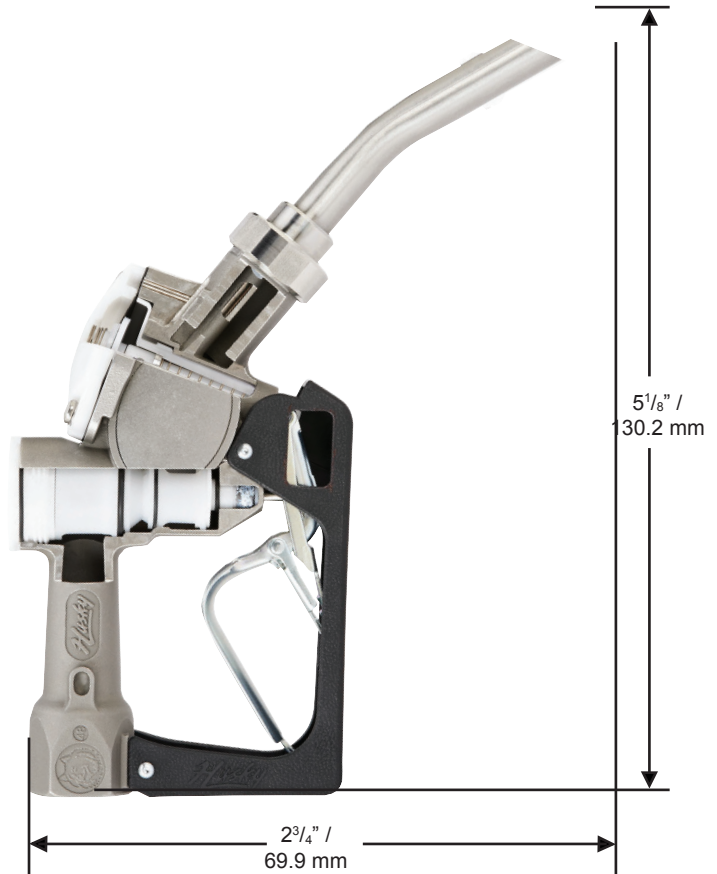

Polymer DEF Nozzle



Polymer shut off Diesel Exhaust Fluid (DEF) nozzle for full-service and self-service stations.

- Lighter than stainless steel nozzles.
- *Streamshaper™* reduces turbulence for straighter fuel flow and less splash back spillage.
- Less expensive than comparable nozzles.
- Nozzle shuts off when the DEF tank is full.
- Stainless steel spout for durability.
- Replaceable stainless steel spout.
- Lower lever force.
- C3 position hold open latch.
- Flow characteristics of nozzle reduces crystallization of DEF.
- Complies with ISO Standard 22241-2:2006.



New Polymer DEF Nozzle

MODEL NO.	DESCRIPTION	SHIPPING WEIGHT LBS (KG)
873504	Polymer DEF Nozzle	1.53 (0.7)

Construction

Body	Acetal
Seals	Fluorocarbon o-rings and diaphragm
Spout	19 mm diameter
Lever	One-piece contoured steel with hard plastic cover
Inlet	1" BSPP Male/Female seal

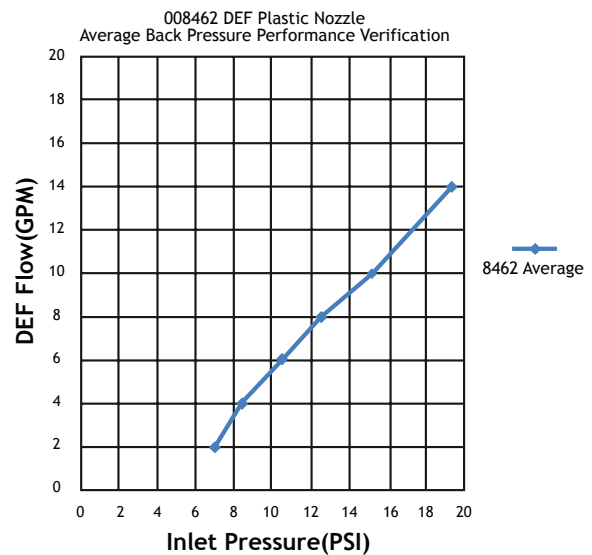

Polymer shut off Diesel Exhaust Fluid (DEF) nozzle for full-service and self-service stations.

Dimensions and System Options

Safe-T-Breaks®

MODEL NO.	DESCRIPTION
7219	1" M x 1" M BSPP Non-Reconnectable Stainless Steel Safe-T-Break®
7204	1" M x 1" M BSPP Non-Reconnectable HDPE Safe-T-Break®

Swivel

MODEL NO.	DESCRIPTION
7269	1" M x 1" M BSPP Inline Swivel

Spouts

MODEL NO.	DESCRIPTION
7360	with Spout Ring; without Magnetic Accufuel™ safety feature
7364	with Spout Ring and Magnetic Accufuel™ safety feature
7362	without Spout Ring and Magnetic Accufuel™ safety feature

Guards

MODEL NO.	DESCRIPTION
0226	Mate Nozzle Guard
7376	Handle Cover (Black)
1808	Waffle Splash Guard
8429	DEF Hand Guard Repair Kit

Adaptors

MODEL NO.	DESCRIPTION
7285	1" M x 1" M BSPP Straight Adaptor
7356	1" M BSPP x M M34 Straight Adaptor
8529	1" F x 3/4" M Adaptor (NPTF threads)

Accessories, Testing and Maintenance

MODEL NO.	DESCRIPTION
7523	1" BSPP Seal Kit Assembly
7150	Poppet Valve / Venturi Cartridge Assembly
7160	Plunger Cartridge Assembly
7163	Loss Motion Diaphragm Cartridge Assembly





Husky

GENERAL FUELING PRODUCTS

**Truck &
High Volume
Nozzles**

1690 Nozzles



Husky 1690 nozzle is 30% lighter than similar nozzles.

- Nozzle designed with extra large hand opening to accommodate gloves or mittens.
- Check valve is in nozzle body, not the spout, for inexpensive and fast spout replacement.
- Includes a self-adjusting stem packing.
- Automatic shut-off with dual poppets for easy opening.
- Two position hold open latch.
- Right angle design allows nozzle to “fit” close to walls and corners.
- Cast-in protective standoff provide durability with rough usage.
- Model 1691 includes a CUL approved spout.



New Nozzles w/ NPTF Threads

MODEL NO.	DESCRIPTION	SHIPPING WEIGHT LBS (KG)
169010	without shear groove in spout	4.6 (2.0)
169110	with shear groove in spout	4.6 (2.0)

Rebuilt Nozzles w/ NPTF Threads

MODEL NO.	DESCRIPTION	SHIPPING WEIGHT LBS (KG)
169410	without shear groove in spout	4.6 (2.0)
169510	with shear groove in spout	4.6 (2.0)

New Nozzles w/ BSPP Threads

MODEL NO.	DESCRIPTION	SHIPPING WEIGHT LBS (KG)
169038	without shear groove in spout	4.6 (2.0)

Construction

Body	Die cast aluminum body
Seals	Fluorocarbon
Packing	Double o-ring seal protected by fiber reinforced Teflon
Lever	One piece contoured steel
Inlet	1½” NPTF and BSPP

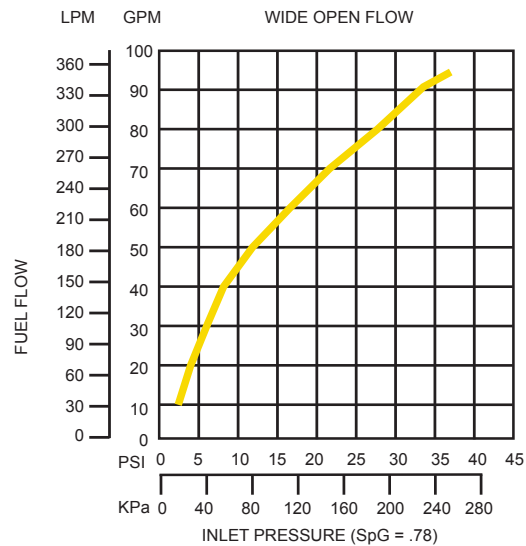

Husky 1690 nozzle is 30% lighter than similar nozzles.

Dimensions and System Options

Swivels

MODEL NO.	DESCRIPTION
5240	1¼" F x 1½" M NPTF Single Plane Swivel
5266	1½" F x 1½" M NPTF Single Plane Swivel
5754	1¼" F x 1½" M BSPP Single Plane Swivel
5755	1½" F x 1½" M BSPP Single Plane Swivel

Spouts

MODEL NO.	DESCRIPTION
4889	Spout Assembly without shear groove
5042	Spout Assembly with shear groove

Pressure/Vacuum Vents

MODEL NO.	DESCRIPTION
4620	2" Slip-On Pressure Vacuum Vent
4885	2" Thread-On Pressure Vacuum Vent - NPTF
5885	2" Thread-On Pressure Vacuum Vent with internal screen - NPTF

Accessories, Testing and Maintenance

MODEL NO.	DESCRIPTION
7089	Nozzle Service Kit

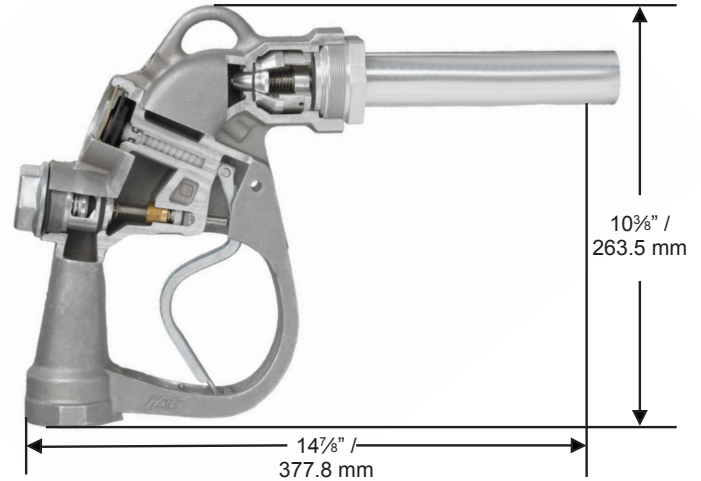

1690 CW Nozzles



Husky

GENERAL FUELING PRODUCTS

High volume automatic shut-off nozzle provides 100 gpm and is 30% lighter than similar nozzles.

- Contains a poppet disc seal, rated at -40°F/C (exceeding the UL standard of -20°F / -29°C) to prevent fuel leakage from the main seal in extreme cold weather.
- Nozzle is designed with extra large hand opening to accommodate gloves or mittens.
- Check valve is in the nozzle body, not the spout, for inexpensive, fast spout replacement.
- Two position hold open latch.
- Self-adjusting stem packing - no field adjustment is required.
- Automatic shut-off with dual poppets for easy opening.
- Right angle design allows nozzle to "fit" close to walls and corners.
- Cast-in protective standoff provide durability with rough usage.
- Model 652510 has a CUL approved spout.

New Nozzles

MODEL NO.	DESCRIPTION	SHIPPING WEIGHT LBS (KG)
652310	w/ two position hold-open latch	3.96 (1.79)
652510	w/ two position hold-open latch and CUL spout	3.96 (1.79)

CONSTRUCTION

Body	Die Cast Aluminum
Seals	Fluorocarbon
Packing	Double o-ring seal protected by fiber reinforced teflon
Lever	One piece contoured steel with hard plastic cover
Inlet	1½ in / 38 mm NPTF
Spout	13 8 in / 34.9 mm O.D

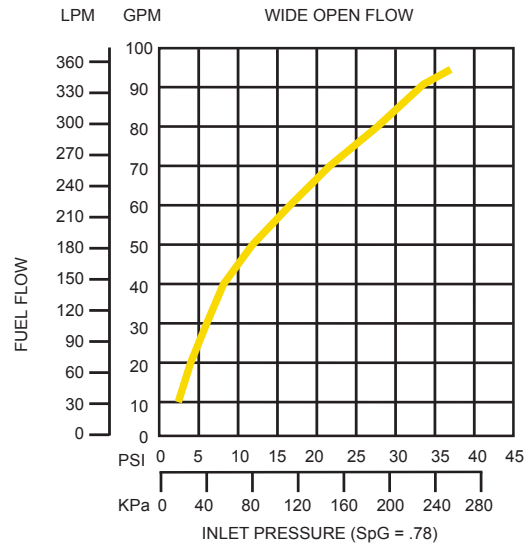

**Husky**

GENERAL FUELING PRODUCTS

1690 CW Nozzles

High volume automatic shut-off nozzle provides 100 gpm and is 30% lighter than similar nozzles.

Dimensions and System Options

Swivels

MODEL NO.	DESCRIPTION
5235	1¼ in / 32 mm F x 1¼ in / 32 mm M Inline Swivel
5240	1¼ in / 32 mm F x 1½ in / 38 mm M Inline Swivel
5265	1½ in / 38 mm F x 1¼ in / 32 mm M Inline Swivel
5266	1½ in / 38 mm F x 1½ in / 38 mm M Inline Swivel

Spouts

MODEL NO.	DESCRIPTION
4889	Spout w/o shear groove (U.S. version)
5042	Spout w/ shear groove (Canadian version)

Pressure/Vacuum Vents

MODEL NO.	DESCRIPTION
4620	2" Slip-On Pressure Vacuum Vent
4885	2" Thread-On Pressure Vacuum Vent - NPTF
5885	2" Thread-On Pressure Vacuum Vent with internal screen - NPTF

Accessories, Testing, and Maintenance

MODEL NO.	DESCRIPTION
7089	Nozzle Service Kit

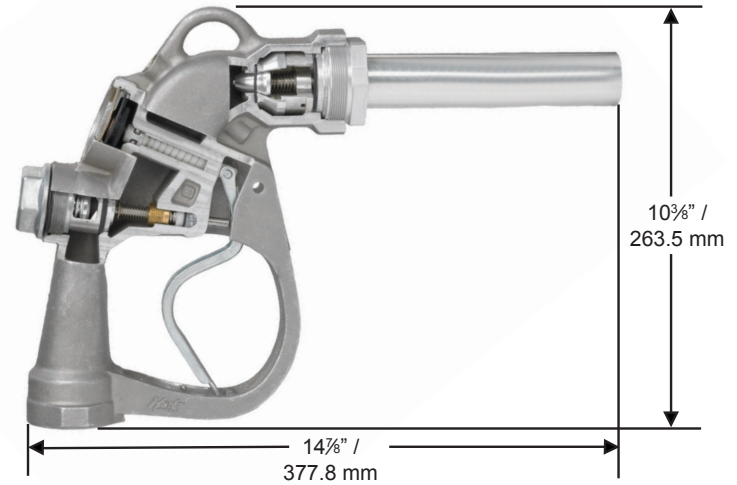

MADE IN THE U.S.A.

Automatic shut-off nozzle for dispensing up to 25 gpm / 94.6 Lpm.

- 1HS nozzle shuts off when the gas tank is full.
- Heavy-duty, long-lasting metal hand guard.
- Accu-Flo™ poppet allows “to-the-penny” fuel dispensing.
- Equipped with a unique Flo- Stop™ device that shuts off the nozzle if it falls from the fill tank or raises above the horizontal.
- Comes standard with full grip guard and waffle splash guard.



New Diesel Nozzles w/ NPTF Threads

MODEL NO.	DESCRIPTION	SHIPPING WEIGHT LBS (KG)
696310	with Three Notch Hold Open Clip	3.4 (1.5)
696365	with Three Notch Hold Open Clip and Waffle Splash Guard	3.6 (1.6)
696312	without Hold Open Clip	3.4 (1.5)

Rebuilt Diesel Nozzles w/ NPTF Threads

MODEL NO.	DESCRIPTION	SHIPPING WEIGHT LBS (KG)
696610	with Three Notch Hold Open Clip	3.4 (1.5)
696665	with Three Notch Hold Open Clip and Waffle Splash Guard	3.3 (1.4)
696612	without Hold Open Clip	3.4 (1.5)

New Diesel Nozzles w/ BSPP Threads

MODEL NO.	DESCRIPTION	SHIPPING WEIGHT LBS (KG)
696338	with Three Notch Hold Open Clip	3.4 (1.5)
696340	without Hold Open Clip	3.4 (1.5)

Construction

Body	Die cast aluminum
Seals	Fluorocarbon
Packing	Double o-ring seal protected by fiber reinforced Teflon
Lever	One piece contoured steel with hard plastic cover
Inlet	1" / 25.4 mm NPTF & BSPP

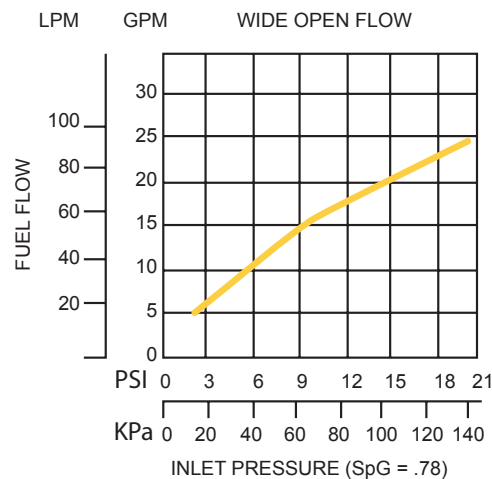

**Husky**

GENERAL FUELING PRODUCTS

1HS Nozzles

Automatic shut-off nozzle for dispensing up to 25 gpm / 94.6 Lpm.

Dimensions and System Options

Safe-T-Breaks®

MODEL NO.	DESCRIPTION
2276	1" F x 1" F NPTF Reconnectable Safe-T-Break®
5812	1" F x 1" F NPTF Non-Reconnectable Safe-T-Break
6301	1" F x 1" F NPTF Non-Reconnectable PCC Safe-T-Break®
5231	1" F x 1" F NPTF Low Pull Reconnectable Safe-T-Break®
3076	1" F x 1" F BSPP Reconnectable Safe-T-Break®
3076A	1" F x 1" F BSPP Reconnectable Safe-T-Break® - Atex
6914	1" F x 1" F BSPP Non-Reconnectable Safe-T-Break®

Swivels

MODEL NO.	DESCRIPTION
0087	1" M x 1" F NPTF Multi-Plane Swivel
0087W	1" M x 1" F NPTF Multi-Plane Swivel with Warm Weather Seals
4860	1" M x 1" F NPTF Multi-Plane High Flow Swivel
0095	1" M x 1" F NPTF 70° Pump Swivel
3395	1" M x 1" F NPTF Multi-Plane Restricted Swivel
3306	1" M x 1" F BSPP Multi-Plane Swivel
3306W	1" M x 1" F BSPP Multi-Plane Swivel with Warm Weather Seals
6949	1" M x 1" F BSPP Multi-Plane High Flow Swivel

Swivel/Safe-T-Break® Combos

MODEL NO.	DESCRIPTION
5969	1" M NPTF Multi-Plane Swivel connected to 1" F NPTF Reconnectable Safe-T-Break®
8015	1" M BSPP Multi-Plane Swivel connected to 1" F BSPP Reconnectable Safe-T-Break®

Spouts

MODEL NO.	DESCRIPTION
5215	Heavy Duty Diesel Spout with Flo-Stop™

Pressure/Vacuum Vents

MODEL NO.	DESCRIPTION
4620	2" Slip-On Pressure Vacuum Vent
4885	2" Thread-On Pressure Vacuum Vent - NPTF
5885	2" Thread-On Pressure Vacuum Vent with internal screen - NPTF

Accessories, Testing and Maintenance

MODEL NO.	DESCRIPTION
7089	Nozzle Service Kit
3593	Hold Open Clip Kit

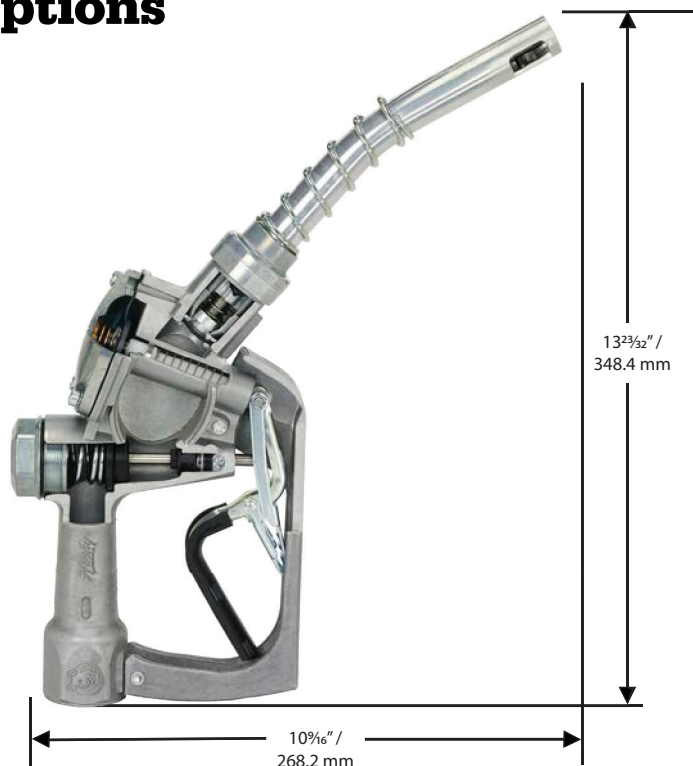

Guards

MODEL NO.	DESCRIPTION
0554	Full Grip Nozzle Guard
6655	POPD™ S Full Grip Guard
8183	POPD™ H Full Grip Guard
1804	Full Grip Nozzle Reguard
7210	POPD™ S Full Grip Reguard
8190	POPD™ H Full Grip Reguard
0226	Mate Nozzle Guard
8169	POPD™ S Mate Guard
8170	POPD™ H Mate Guard
8179	POPD™ EZS Nozzle Guard
8180	POPD™ EZH Nozzle Guard
1808	Waffle Splash Guard
0099	Protection Package
1811	Reguard Package
6628	POPD™ S Clear Cover
7999	POPD™ H Clear Cover
5494	Lever Guard
7295	Mate Handle Cover
7376	Mate Handle Cover



MADE IN THE U.S.A.



1HS Nozzles



- 1HS nozzle shuts off when the gas tank is full.
- Accu-Flo™ poppet allows “to-the-penny” fuel dispensing.
- Equipped with a unique Flo- Stop™ device that shuts off the nozzle if it falls from the fill tank or raises above the horizontal. Comes standard with full grip guard and waffle splash guard.



New Diesel Nozzles w/ NPTF Threads

MODEL NO.	DESCRIPTION	SHIPPING WEIGHT LBS (KG)
026810	with Three Notch Hold Open Clip	3.4 (1.5)
026865	with Three Notch Hold Open Clip and Waffle Splash Guard	3.6 (1.6)
026890	with Three Notch Hold Open Clip, POPD Full Grip Guard and Waffle Splash Guard	3.4 (1.5)
026812	without Hold Open Clip	3.4 (1.5)

Rebuilt Diesel Nozzles w/ NPTF Threads

MODEL NO.	DESCRIPTION	SHIPPING WEIGHT LBS (KG)
052410	with Three Notch Hold Open Clip	3.4 (1.5)
052465	with Three Notch Hold Open Clip and Waffle Splash Guard	3.3 (1.4)
052412	without Hold Open Clip	3.4 (1.5)

New Diesel Nozzles w/ BSPP Threads

MODEL NO.	DESCRIPTION	SHIPPING WEIGHT LBS (KG)
026838	with Three Notch Hold Open Clip	3.4 (1.5)
026840	without Hold Open Clip	3.4 (1.5)

Rebuilt Diesel Nozzles w/ BSPP Threads

MODEL NO.	DESCRIPTION	SHIPPING WEIGHT LBS (KG)
052438	with Three Notch Hold Open Clip	3.4 (1.5)

Construction

Body	Die cast aluminum body with high impact polymer hand guard
Seals	Fluorocarbon
Packing	Double o-ring seal protected by fiber reinforced Teflon
Lever	One piece contoured steel with hard plastic cover
Inlet	1" / 25.4 mm NPTF and BSPP

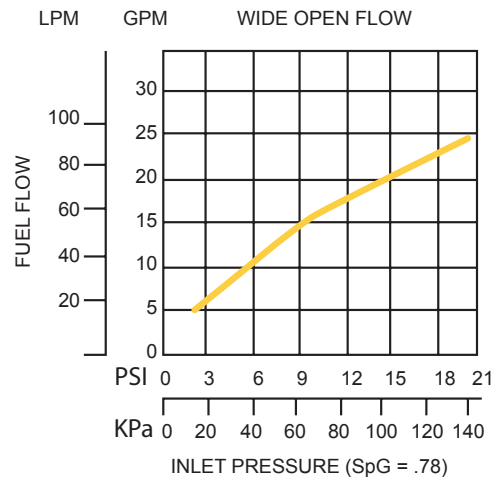

Automatic shut-off nozzle for dispensing up to 25 gpm / 94.6 Lpm.

Dimensions and System Options

Safe-T-Breaks®

MODEL NO.	DESCRIPTION
2276	1" F x 1" F NPTF Reconnectable Safe-T-Break®
5812	1" F x 1" F NPTF Non-Reconnectable Safe-T-Break®
6301	1" F x 1" F NPTF Non-Reconnectable PCC Safe-T-Break®
5231	1" F x 1" F NPTF Low Pull Reconnectable Safe-T-Break®
3076	1" F x 1" F BSPP Reconnectable Safe-T-Break®
3076A	1" F x 1" F BSPP Reconnectable Safe-T-Break® - Atex
6914	1" F x 1" F BSPP Non-Reconnectable Safe-T-Break®

Swivels

MODEL NO.	DESCRIPTION
0087	1" M x 1" F NPTF Multi-Plane Swivel
0087W	1" M x 1" F NPTF Multi-Plane Swivel with Warm Weather Seals
4860	1" M x 1" F NPTF Multi-Plane High Flow Swivel
0095	1" M x 1" F NPTF 70° Pump Swivel
3395	1" M x 1" F NPTF Multi-Plane Restricted Swivel
3306	1" M x 1" F BSPP Multi-Plane Swivel
3306W	1" M x 1" F BSPP Multi-Plane Swivel with Warm Weather Seals
6949	1" M x 1" F BSPP Multi-Plane High Flow Swivel

Swivel/Safe-T-Break® Combos

MODEL NO.	DESCRIPTION
5969	1" M NPTF Multi-Plane Swivel connected to 1" F NPTF Reconnectable Safe-T-Break®
8015	1" M BSPP Multi-Plane Swivel connected to 1" F BSPP Reconnectable Safe-T-Break®

Spouts

MODEL NO.	DESCRIPTION
5215	Heavy Duty Diesel Spout with Flo-Stop™

Pressure/Vacuum Vents

MODEL NO.	DESCRIPTION
4620	2" Slip-On Pressure Vacuum Vent
4885	2" Thread-On Pressure Vacuum Vent - NPTF
5885	2" Thread-On Pressure Vacuum Vent with internal screen - NPTF

Accessories, Testing and Maintenance

MODEL NO.	DESCRIPTION
7089	Nozzle Service Kit
3593	Hold Open Clip Kit

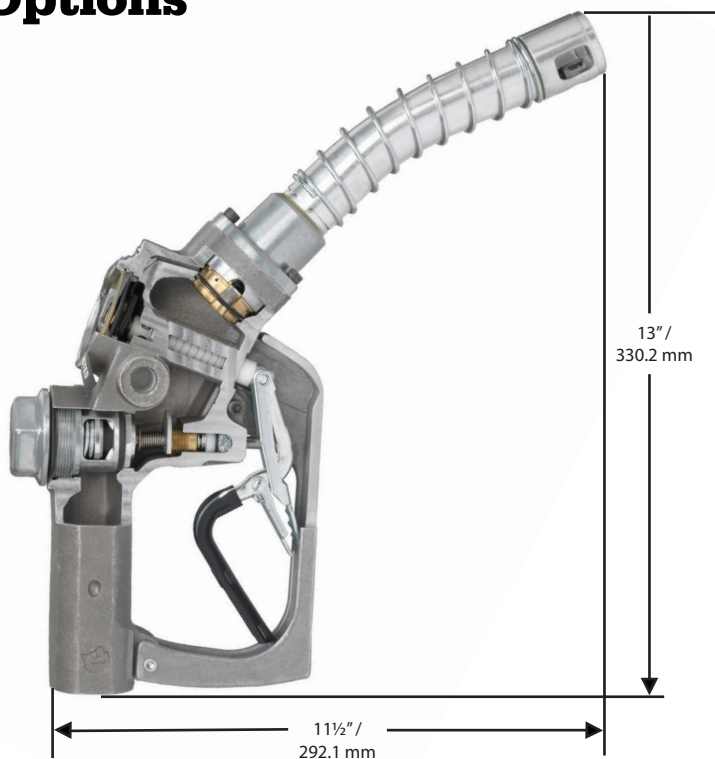

Guards

MODEL NO.	DESCRIPTION
0554	Full Grip Nozzle Guard
6655	POPD™ S Full Grip Guard
8183	POPD™ H Full Grip Guard
1804	Full Grip Nozzle Reguard
7210	POPD™ S Full Grip Reguard
8190	POPD™ H Full Grip Reguard
0226	Mate Nozzle Guard
8169	POPD™ S Mate Guard
8170	POPD™ H Mate Guard
8179	POPD™ EZS Nozzle Guard
8180	POPD™ EZH Nozzle Guard
1808	Waffle Splash Guard
0099	Protection Package
1811	Reguard Package
6628	POPD™ S Clear Cover
7999	POPD™ H Clear Cover
5494	Lever Guard
7376	Mate Handle Cover

VIII Nozzles



Automatic shut-off nozzle for truck stop and other high volume full-service, self-service and unattended stations.

- VIII nozzle shuts off when the gas tank is full.
- Spout is reinforced with thick aluminum bushing that retains spout spring and keeps spout from rounding-in; the two leading causes of clicking off and splash-back spillage.
- Equipped with a unique Flo- Stop™ device that shuts off the nozzle if it falls from the fill tank or raises above the horizontal.
- Comes standard with full grip guard and waffle splash guard.

New Heavy Duty Diesel Nozzles w/ NPTF Threads

MODEL NO.	DESCRIPTION	SHIPPING WEIGHT LBS (KG)
173310	with Three Notch Hold Open Clip, Waffle Splash Guard and Spout Bushing	3.9 (1.7)
17331001	with Three Notch Hold Open Clip, Waffle Splash Guard, Long Spout and Spout Bushing	4.0 (1.8)
173312	without Hold Open Clip, with Waffle Splash Guard and Spout Bushing	3.9 (1.7)
503010	with Three Notch Hold Open Clip and Waffle Splash Guard without Spout Bushing	3.9 (1.7)
503012	without Hold Open Clip and Spout Bushing, with Waffle Splash Guard	3.9 (1.7)
503081	with Three Notch Hold Open Clip, without Spout Bushing and Waffle Splash Guard	3.9 (1.7)

Rebuilt Heavy Duty Diesel Nozzles w/ NPTF Threads

MODEL NO.	DESCRIPTION	SHIPPING WEIGHT LBS (KG)
265910	with Three Notch Hold Open Clip, Waffle Splash Guard and Spout Bushing	3.9 (1.7)
265912	without Hold Open Clip, with Waffle Splash Guard and Spout Bushing	3.9 (1.7)
502510	with Three Notch Hold Open Clip and Waffle Splash Guard without Spout Bushing	3.9 (1.7)
502512	without Hold Open Clip and Spout Bushing, with Waffle Splash Guard	3.9 (1.7)

Construction

Body	Aluminum
Seals	Fluorocarbon
Packing	Double o-ring seal protected by fiber reinforced Teflon
Lever	One piece contoured steel
Inlet	1" / 25.4 mm NPTF

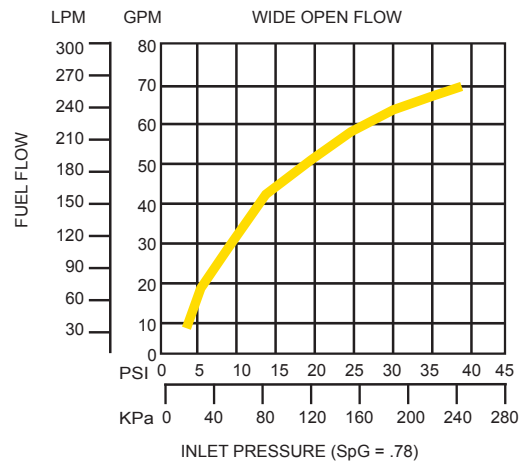

**Husky**

GENERAL FUELING PRODUCTS

VIII Nozzles

Automatic shut-off nozzle for truck stop and other high volume full-service, self-service and unattended stations.

Dimensions and System Options

Safe-T-Breaks®

MODEL NO.	DESCRIPTION
2276	1" F x 1" F Reconnectable Safe-T-Break®
5812	1" F x 1" F Non-Reconnectable Safe-T-Break®
6301	1" F x 1" F Non-Reconnectable PCC Safe-T-Break®
5231	1" F x 1" F Low Pull Reconnectable Safe-T-Break®

Swivels

MODEL NO.	DESCRIPTION
0087	1" M x 1" F Multi-Plane Swivel
0087W	1 M x 1" F Multi-Plane Swivel with Warm Weather Seals
4860	1" M x 1" F Multi-Plane High Volume Swivel
0095	1" M x 1" F Multi-Plane 70° Pump Swivel
3395	1" M x 1" F Multi-Plane Restricted Swivel

Swivel/Safe-T-Break® Combos

MODEL NO.	DESCRIPTION
5969	1" M Multi-Plane Swivel connected to 1" F Reconnectable Safe-T-Break®

Spouts

MODEL NO.	DESCRIPTION
2279	Complete Spout Assembly with Spout Bushing
5017	Complete Spout Assembly without Spout Bushing
3589	Complete Long Spout Assembly with Spout Bushing

Pressure/Vacuum Vents

MODEL NO.	DESCRIPTION
4620	2" Slip-On Pressure Vacuum Vent
4885	2" Thread-On Pressure Vacuum Vent - NPTF
5885	2" Thread-On Pressure Vacuum Vent with internal screen - NPTF

Accessories, Testing and Maintenance

MODEL NO.	DESCRIPTION
7089	Nozzle Service Kit
3593	Hold Open Clip Kit

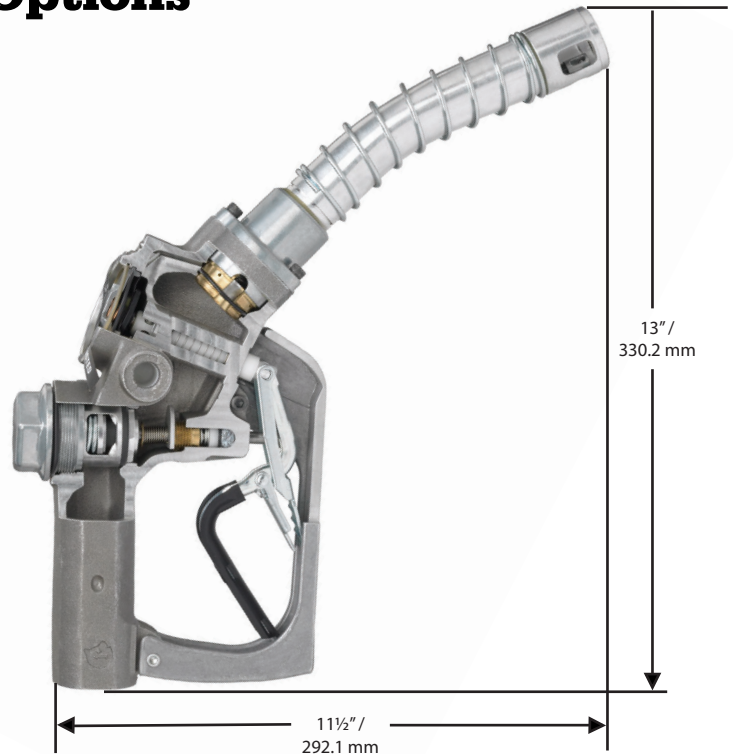

Guards

MODEL NO.	DESCRIPTION
4740	Full Grip Guard
7352	POPD™ S Full Grip Guard
8186	POPD™ H Full Grip Guard
5516	Full Grip Reguard
8194	POPD™ S Full Grip Reguard
8193	POPD™ H Full Grip Reguard
1808	Waffle Splash Guard
8167	POPD™ S Mate Guard
8168	POPD™ H Mate Guard
8177	POPD™ EZS Nozzle Guard
8178	POPD™ EZH Nozzle Guard
6628	POPD™ S Clear Cover
7999	POPD™ H Clear Cover
5494	Lever Guard



MADE IN THE U.S.A.



VIII BSPP Nozzles



Automatic shut off nozzle for truck stop and other high volume full-service, self-service and unattended stations.

- VIII nozzle shuts off when
 - the pump shuts off.
 - the gas tank is full.
 - the lever is opened before the pump is turned on.
 - the leak detector has not completed the test cycle.
- Spout is reinforced with thick aluminum bushing that retains spout spring and keeps spout from rounding-in: the two leading causes of clicking off and splash-back spillage.
- Comes standard with smooth full grip guard and waffle splash guard.
- Equipped with a unique Flo-Stop™ device that shuts off the nozzle if it falls from the fill tank or raises above the horizontal.



New Nozzles

MODEL NO.	DESCRIPTION	SHIPPING WEIGHT LBS (KG)
173338	w/ Three Notch Hold Open Clip, Waffle Splash Guard and Spout Bushing	4.5 (2.0)
503038	w/ Three Notch Hold Open Clip and Waffle Splash Guard, w/o Spout Bushing	4.5 (2.0)
503040	w/o Hold Open Clip and Spout Bushing, w/ Waffle Splash Guard	4.5 (2.0)

Construction

Body	Aluminum
Seals	Fluorocarbon
Packing	Double o-ring seal protected by fiber reinforced Teflon
Lever	One piece contoured steel
Inlet	1" / 25.4 mm BSPP

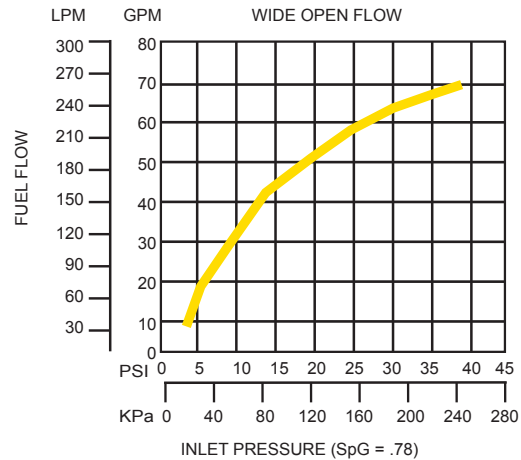

**Husky**

GENERAL FUELING PRODUCTS

VIII BSPP Nozzles

Automatic shut off nozzle for truck stop and other high volume full-service, self-service and unattended stations.

Dimensions and System Options

BSPP Safe-T-Breaks®

MODEL NO.	DESCRIPTION
3076	1" F x 1" F Reconnectable Safe-T-Break®
3076A	1" F x 1" F Reconnectable Safe-T-Break® - ATEX
6914	1" F x 1" F Non-Reconnectable Safe-T-Break®

BSPP Swivels

MODEL NO.	DESCRIPTION
3306	1" M x 1" F Multi-Plane Swivel
3306W	1" M x 1" F Multi-Plane Swivel with Warm Weather Seals
6949	1" M x 1" F Multi-Plane High Flow Swivel

BSPP Swivel/Safe-T-Break® Combos

MODEL NO.	DESCRIPTION
8015	1" M BSPP Multi-Plane Swivel connected to 1" F BSPP Reconnectable Safe-T-Break®

Spouts

MODEL NO.	DESCRIPTION
2279	Complete Spout Assembly Kit w/ Bushing
5017	Complete Spout Assembly Kit w/o Bushing
3589	Complete Long Spout Assembly w/ Spout Bushing

Pressure/Vacuum Vents

MODEL NO.	DESCRIPTION
4620	2" Slip-On Pressure Vacuum Vent
4885	2" Thread-On Pressure Vacuum Vent - NPTF
5885	2" Thread-On Pressure Vacuum Vent with internal screen - NPTF

Accessories, Testing and Maintenance

MODEL NO.	DESCRIPTION
7089	Nozzle Service Kit
3593	Hold Open Clip Kit

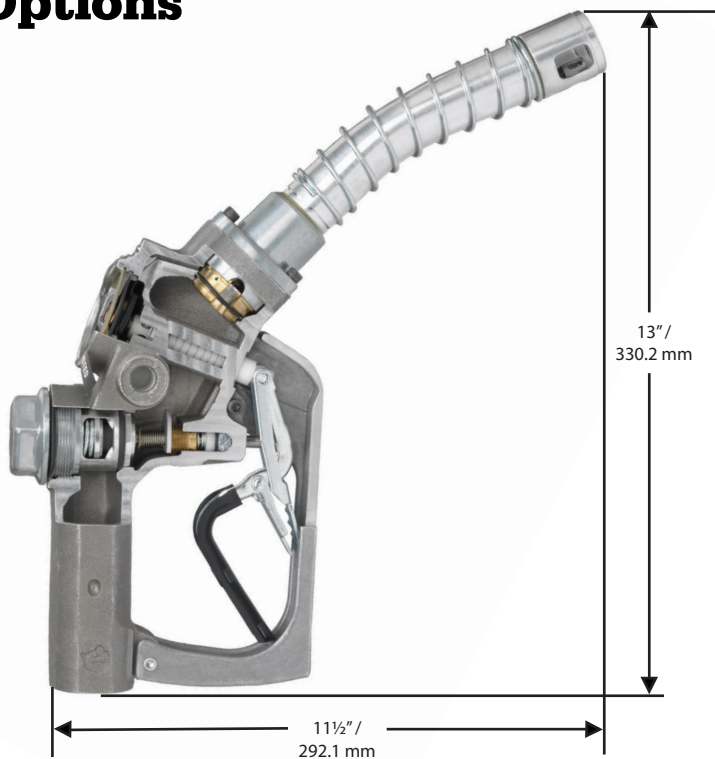

Guards

MODEL NO.	DESCRIPTION
4740	Full Grip Guard
7352	POPD™ S Full Grip Guard
8186	POPD™ H Full Grip Guard
5516	Full Grip Reguard
8194	POPD™ S Full Grip Reguard
8193	POPD™ H Full Grip Reguard
8167	POPD™ S Mate Guard
8168	POPD™ H Mate Guard
1808	Waffle Splash Guard
8177	POPD™ EZS Nozzle Guard
8178	POPD™ EZH Nozzle Guard
6628	POPD™ S Clear Cover
7999	POPD™ H Clear Cover
5494	Lever Cover



MADE IN THE U.S.A.



VIII CW Nozzles



Automatic shut-off nozzle for truck stops and other high volume applications.

- Nozzle shuts off when the gas tank is full.
- Nozzle is equipped with a unique Flo-Stop™ device that shuts off the nozzle if it falls from the fill tank or raises above the horizontal.
- Contains a poppet disc seal designed to prevent fuel leakage from the main seal in extreme cold weather.
- Nozzle can get flow rates up to 75 GPM / 341 LPM.
- Standard nozzle spout is reinforced with a thick aluminum bushing that holds the spout spring in place and keeps the spout from rounding in.
- Comes standard with Full Grip Guard and Waffle Splash Guard.

New Nozzles

MODEL NO.	DESCRIPTION	SHIPPING WEIGHT LBS (KG)
651510	with Spout Bushing, Three Notch Hold Open Clip and Waffle Splash Guard	4.5 (2.0)
651512	without Hold Open Clip with Full Grip Guard, 1808 Waffle Splash Guard	4.6 (2.1)
651710	without Spout Bushing, with Three Notch Hold Open Clip and Waffle Splash Guard	4.5 (2.0)
651712	without Hold Open Clip with Full Grip Guard and 1808 Waffle Splash Guard	4.6 (2.1)

Construction

Body	Aluminum
Seals	Fluorocarbon
Packing	Double o-ring seal protected by fiber reinforced Teflon
Lever	One piece contoured steel with hard plastic cover
Inlet	1" / 25.4 mm NPTF

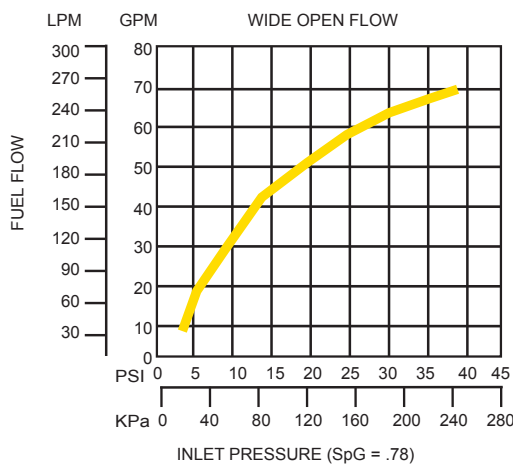

**Husky**

GENERAL FUELING PRODUCTS

VIII CW Nozzles

Automatic shut-off nozzle for truck stops and other high volume applications.

Dimensions and System Options

Safe-T-Breaks®

MODEL NO.	DESCRIPTION
2276	1" F x 1" F Reconnectable Safe-T-Break®
5812	1" F x 1" F Non-Reconnectable Safe-T-Break®
6301	1" F x 1" F Non-Reconnectable PCC Safe-T-Break®
5231	1" F x 1" F Low Pull Reconnectable Safe-T-Break®

Swivels

MODEL NO.	DESCRIPTION
0087	1" M x 1" F Multi-Plane Swivel
4860	1" M x 1" F Multi-Plane High Volume Swivel
0095	1" M x 1" F Multi-Plane 70° Pump Swivel
3395	1" M x 1" F Multi-Plane Restricted Swivel

Swivel•Safe-T-Break® Combos

MODEL NO.	DESCRIPTION
5969	1" M Multi-Plane Swivel connected to 1" F Reconnectable Safe-T-Break®

Spouts

MODEL NO.	DESCRIPTION
2279	Complete Spout Assembly Kit w/ Bushing
5017	Complete Spout Assembly Kit w/o Bushing
3589	Complete Long Spout Assembly w/ Spout Bushing

Pressure/Vacuum Vents

MODEL NO.	DESCRIPTION
4620	2" Slip-On Pressure Vacuum Vent
4885	2" Thread-On Pressure Vacuum Vent - NPTF
5885	2" Thread-On Pressure Vacuum Vent with internal screen - NPTF

Accessories, Testing and Maintenance

MODEL NO.	DESCRIPTION
7089	Nozzle Service Kit

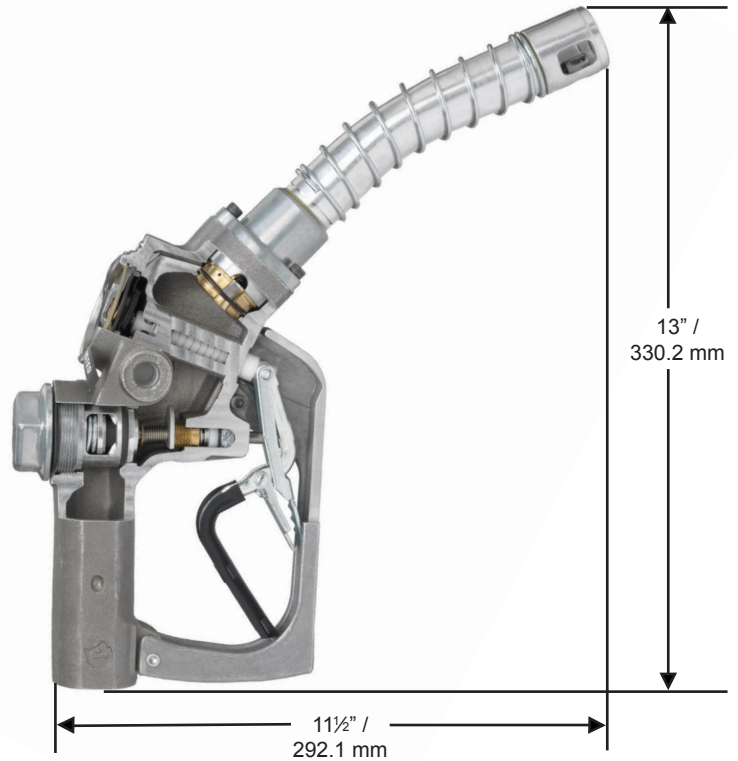

Guards

MODEL NO.	DESCRIPTION
4740	Full Grip Guard
7352	POPD™ S Full Grip Guard
8186	POPD™ H Full Grip Guard
5516	Full Grip Reguard
8194	POPD™ S Full Grip Reguard
8193	POPD™ H Full Grip Reguard
8167	POPD™ S Mate Guard
8168	POPD™ H Mate Guard
1808	Waffle Splash Guard
8177	POPD™ EZS Nozzle Guard
8178	POPD™ EZH Nozzle Guard
6628	POPD™ S Clear Cover
7999	POPD™ H Clear Cover
5494	Lever Cover



MADE IN THE U.S.A.

VIIIS Nozzles



4-8

HIGH VOLUME FUELING

Pressure activated, automatic shut-off nozzle for truck stop and other high volume full-service, self-service and unattended stations.

- VIIIS nozzle shuts off when
 - the pump shuts off.
 - the gas tank is full.
 - the lever is opened before the pump is turned on.
 - the leak detector has not completed the test cycle.
- Spout is reinforced with thick aluminum bushing that retains spout spring and keeps spout from rounding-in; the two leading causes of clicking off and splash-back spillage.
- Equipped with a unique Flo-Stop™ device that shuts off the nozzle if it falls from the fill tank or raises above the horizontal.
- Comes standard with smooth full grip guard and waffle splash guard.



New Heavy Duty Diesel Nozzles w/ NPTF Threads

MODEL NO.	DESCRIPTION	SHIPPING WEIGHT LBS (KG)
177610	with Three Notch Hold Open Clip, Waffle Splash Guard and Spout Bushing	4.6 (2.0)
17761001	with Three Notch Hold Open Clip, Waffle Splash Guard, Long Spout and Spout Bushing	4.6 (2.0)
177690	with Three Notch Hold Open Clip, POPD™ Full Grip Guard, Waffle Splash Guard and Spout Bushing	4.6 (2.0)
177612	without Hold Open Clip, with Waffle Splash Guard and Spout Bushing	4.6 (2.0)
504010	with Three Notch Hold Open Clip and Waffle Splash Guard without Spout Bushing	4.6 (2.0)
504012	without Hold Open Clip and Spout Bushing, with Waffle Splash Guard	4.6 (2.0)

Rebuilt Heavy Duty Diesel Nozzles w/ NPTF Threads

MODEL NO.	DESCRIPTION	SHIPPING WEIGHT LBS (KG)
266010	with Three Notch Hold Open Clip, Waffle Splash Guard and Spout Bushing	4.6 (2.0)
266012	without Hold Open Clip, with Waffle Splash Guard and Spout Bushing	4.6 (2.0)
503510	with Three Notch Hold Open Clip and Waffle Splash Guard without Spout Bushing	4.6 (2.0)
503512	without Hold Open Clip and Spout Bushing, with Waffle Splash Guard	4.6 (2.0)

Construction

Body	Aluminum
Seals	Fluorocarbon
Packing	Double o-ring seal protected by fiber reinforced Teflon
Lever	One piece contoured steel
Inlet	1" / 25.4 mm NPTF

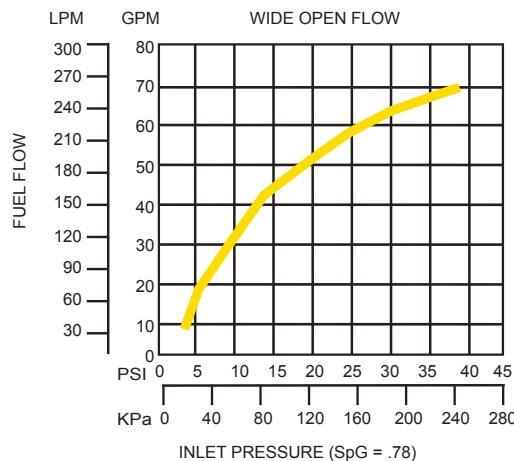

Pressure activated, automatic shut-off nozzle for truck stop and other high volume full-service, self-service and unattended stations.

Dimensions and System Options

Safe-T-Breaks®

MODEL NO.	DESCRIPTION
2276	1" F x 1" F Reconnectable Safe-T-Break®
5812	1" F x 1" F Non-Reconnectable Safe-T-Break®
6301	1" F x 1" F Non-Reconnectable PCC Safe-T-Break®
5231	1" F x 1" F Low Pull Reconnectable Safe-T-Break®

Swivels

MODEL NO.	DESCRIPTION
0087	1" M x 1" F Multi-Plane Swivel
0087W	1 M x 1" F Multi-Plane Swivel with Warm Weather Seals
4860	1" M x 1" F Multi-Plane High Volume Swivel
0095	1" M x 1" F Multi-Plane 70° Pump Swivel
3395	1" M x 1" F Multi-Plane Restricted Swivel

Swivel/Safe-T-Break® Combos

MODEL NO.	DESCRIPTION
5969	1" M Multi-Plane Swivel connected to 1" F Reconnectable Safe-T-Break®

Spouts

MODEL NO.	DESCRIPTION
2279	Complete Spout Assembly with Spout Bushing
5017	Complete Spout Assembly without Spout Bushing
3589	Complete Long Spout Assembly with Spout Bushing

Pressure/Vacuum Vents

MODEL NO.	DESCRIPTION
4620	2" Slip-On Pressure Vacuum Vent
4885	2" Thread-On Pressure Vacuum Vent - NPTF
5885	2" Thread-On Pressure Vacuum Vent with internal screen - NPTF

Accessories, Testing and Maintenance

MODEL NO.	DESCRIPTION
7089	Nozzle Service Kit
3593	Hold Open Clip Kit

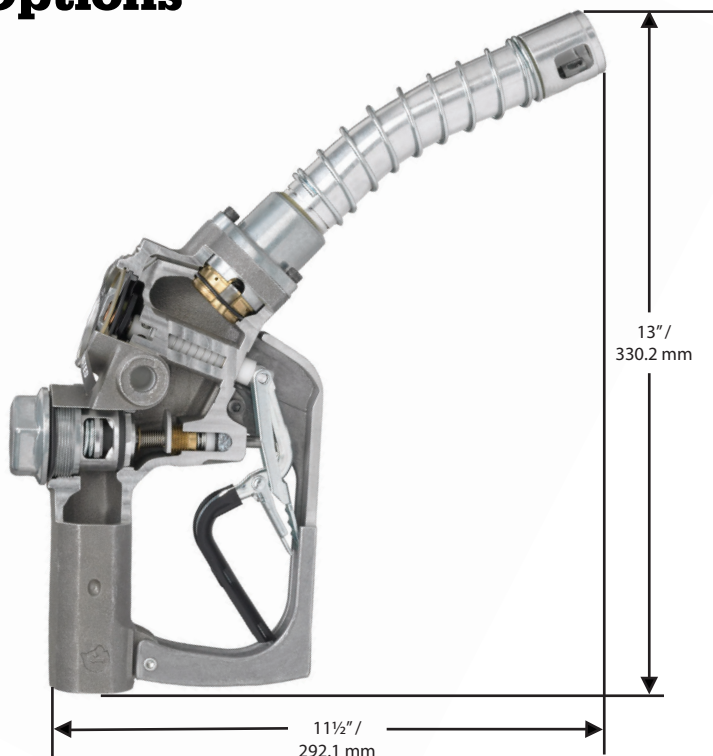

Guards

MODEL NO.	DESCRIPTION
4740	Full Grip Guard
7352	POPD™ S Full Grip Guard
8186	POPD™ H Full Grip Guard
5516	Full Grip Reguard
8194	POPD™ S Full Grip Reguard
8193	POPD™ H Full Grip Reguard
1808	Waffle Splash Guard
8167	POPD™ S Mate Guard
8168	POPD™ H Mate Guard
8177	POPD™ EZS Nozzle Guard
8178	POPD™ EZH Nozzle Guard
6628	POPD™ S Clear Cover
7999	POPD™ H Clear Cover
5494	Lever Guard

VIIIS BSPP Nozzles



Husky

GENERAL FUELING PRODUCTS

4-9

HIGH VOLUME FUELLING

Pressure activated, automatic shut-off nozzle for truck stop and other high volume full-service, self-service and unattended stations.

- VIIIS nozzle shuts off when
 - the pump shuts off.
 - the gas tank is full.
 - the lever is opened before the pump is turned on.
 - the leak detector has not completed the test cycle.
- Spout is reinforced with thick aluminum bushing that retains spout spring and keeps spout from rounding-in: the two leading causes of clicking off and splash-back spillage.
- Comes standard with smooth full grip guard and waffle splash guard.
- Equipped with a unique Flo-Stop™ device that shuts off the nozzle if it falls from the fill tank or raises above the horizontal.



New Nozzles

MODEL NO.	DESCRIPTION	SHIPPING WEIGHT LBS (KG)
177638	w/ Three Notch Hold Open Clip, Waffle Splash Guard and Spout Bushing	3.9 (1.7)
177640	w/o Hold Open Clip, w/ Waffle Splash Guard and Spout Bushing	3.9 (1.7)

Rebuilt Heavy Duty Diesel Nozzle

MODEL NO.	DESCRIPTION	SHIPPING WEIGHT LBS (KG)
266038	w/ Three Notch Hold Open Clip, Waffle Splash Guard and Spout Bushing	3.9 (1.7)

Construction

Body	Aluminum
Seals	Fluorocarbon
Packing	Double o-ring seal protected by fiber reinforced Teflon
Lever	One piece contoured steel
Inlet	1" / 25.4 mm BSPP

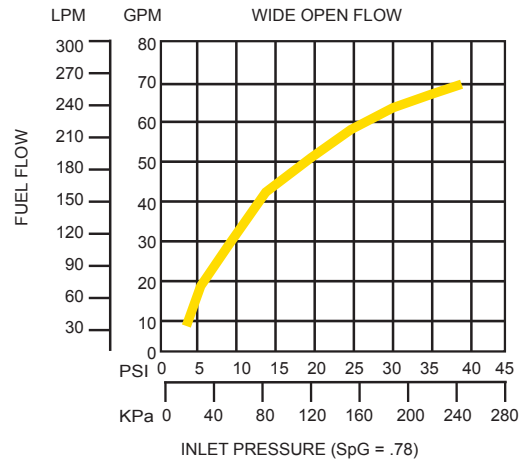

**Husky**

GENERAL FUELING PRODUCTS

VIIIS BSPP Nozzles

Pressure activated, automatic shut-off nozzle for truck stop and other high volume full-service, self-service and unattended stations.

Dimensions and System Options

BSPP Safe-T-Breaks®

MODEL NO.	DESCRIPTION
3076	1" F x 1" F Reconnectable Safe-T-Break®
3076A	1" F x 1" F Reconnectable Safe-T-Break® - ATEX
6914	1" F x 1" F Non-Reconnectable Safe-T-Break®

BSPP Swivels

MODEL NO.	DESCRIPTION
3306	1" M x 1" F Multi-Plane Swivel
3306W	1" M x 1" F Multi-Plane Swivel with Warm Weather Seals
6949	1" M x 1" F Multi-Plane High Flow Swivel

BSPP Swivel/Safe-T-Break® Combos

MODEL NO.	DESCRIPTION
8015	1" M BSPP Multi-Plane Swivel connected to 1" F BSPP Reconnectable Safe-T-Break®

Spouts

MODEL NO.	DESCRIPTION
2279	Complete Spout Assembly Kit w/ Bushing
5017	Complete Spout Assembly Kit w/o Bushing
3589	Complete Long Spout Assembly w/ Spout Bushing

Pressure/Vacuum Vents

MODEL NO.	DESCRIPTION
4620	2" Slip-On Pressure Vacuum Vent
4885	2" Thread-On Pressure Vacuum Vent - NPTF
5885	2" Thread-On Pressure Vacuum Vent with internal screen - NPTF

Accessories, Testing and Maintenance

MODEL NO.	DESCRIPTION
7089	Nozzle Service Kit
3593	Hold Open Clip Kit

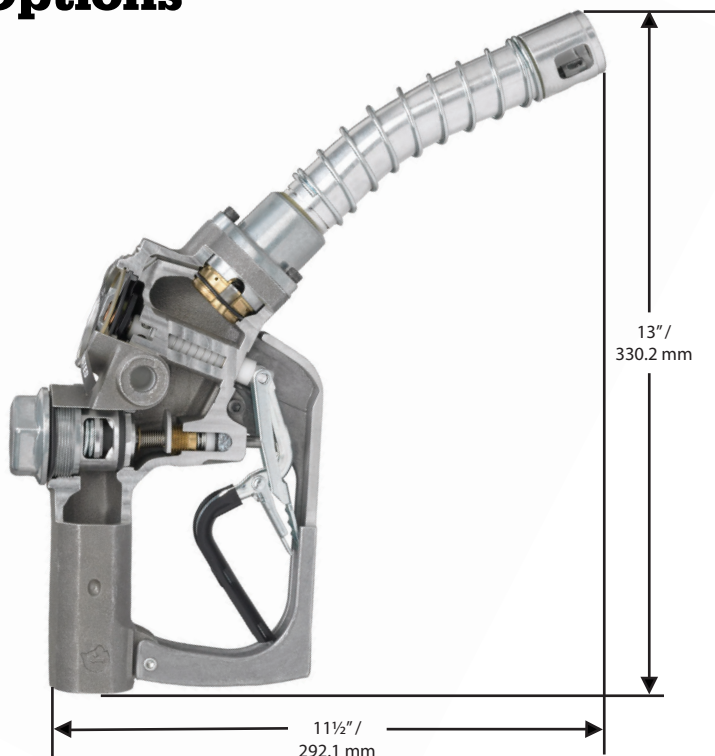

Guards

MODEL NO.	DESCRIPTION
4740	Full Grip Guard
7352	POPD™ S Full Grip Guard
8186	POPD™ H Full Grip Guard
5516	Full Grip Reguard
8194	POPD™ S Full Grip Reguard
8193	POPD™ H Full Grip Reguard
8167	POPD™ S Mate Guard
8168	POPD™ H Mate Guard
1808	Waffle Splash Guard
8177	POPD™ EZS Nozzle Guard
8178	POPD™ EZH Nozzle Guard
6628	POPD™ S Clear Cover
7999	POPD™ H Clear Cover
5494	Lever Cover



MADE IN THE U.S.A.



VIIIS CW Nozzles



Husky

GENERAL FUELING PRODUCTS

4-10

HIGH VOLUME FUELING

Pressure activated nozzle for self-service and unattended stations.

- VIIIS Nozzle shuts off when
 - the pump shuts off.
 - the gas tank is full.
 - the lever is opened before the pump is turned on.
 - the leak detector has not completed the test cycle.
- Equipped with a unique Flo-Stop™ device that shuts off the nozzle if it falls from the fill tank or raises above the horizontal.
- Contains a poppet disc seal, rated at -40° F/C, to prevent fuel leakage from the main seal in extreme cold weather.
- Contains a poppet disc seal designed to prevent fuel leakage from the main seal in extreme cold weather.
- Spout is reinforced with a thick aluminum bushing that holds the spout spring in place and keeps the spout from rounding in - the two leading causes of clicking-off and splash-back spillage.
- Comes standard with Full Grip Nozzle Guard and Waffle Splash Guard.



New Nozzles

MODEL NO.	DESCRIPTION	SHIPPING WEIGHT LBS (KG)
651910	with Spout Bushing, Three Notch Hold Open Clip and Waffle Splash Guard	4.6 (2.0)
652110	without Spout Bushing, with Three Notch Hold Open Clip and Waffle Splash Guard	4.5 (2.0)
651710	without Spout Bushing, with Three Notch Hold Open Clip and Waffle Splash Guard	4.5 (2.0)
651712	without Hold Open Clip with Full Grip Guard and 1808 Waffle Splash Guard	4.6 (2.1)

Construction

Body	Aluminum
Seals	Fluorocarbon
Packing	Double o-ring seal protected by fiber reinforced Teflon
Lever	One piece contoured steel with hard plastic cover
Inlet	1" / 25.4 mm NPTF

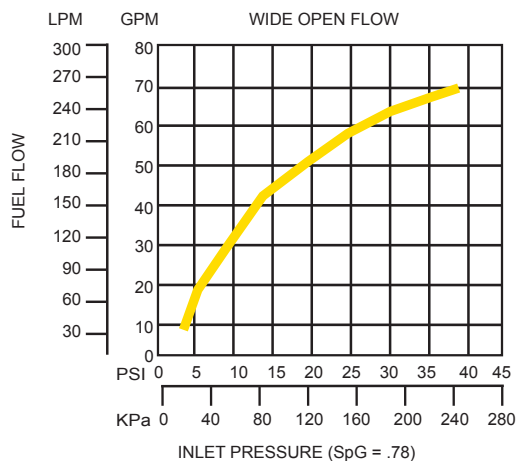

**Husky**

GENERAL FUELING PRODUCTS

VIIIS CW Nozzles

Pressure activated nozzle for self-service and unattended stations.

Dimensions and System Options

Safe-T-Breaks®

MODEL NO.	DESCRIPTION
2276	1" F x 1" F Reconnectable Safe-T-Break®
5812	1" F x 1" F Non-Reconnectable Safe-T-Break®
6301	1" F x 1" F Non-Reconnectable PCC Safe-T-Break®
5231	1" F x 1" F Low Pull Reconnectable Safe-T-Break®

Swivels

MODEL NO.	DESCRIPTION
0087	1" M x 1" F Multi-Plane Swivel
4860	1" M x 1" F Multi-Plane High Volume Swivel
0095	1" M x 1" F Multi-Plane 70° Pump Swivel
3395	1" M x 1" F Multi-Plane Restricted Swivel

Swivel•Safe-T-Break® Combos

MODEL NO.	DESCRIPTION
5969	1" M Multi-Plane Swivel connected to 1" F Reconnectable Safe-T-Break®

Spouts

MODEL NO.	DESCRIPTION
2279	Complete Spout Assembly Kit w/ Bushing
5017	Complete Spout Assembly Kit w/o Bushing
3589	Complete Long Spout Assembly w/ Spout Bushing

Pressure/Vacuum Vents

MODEL NO.	DESCRIPTION
4620	2" Slip-On Pressure Vacuum Vent
4885	2" Thread-On Pressure Vacuum Vent - NPTF
5885	2" Thread-On Pressure Vacuum Vent with internal screen - NPTF

Accessories, Testing and Maintenance

MODEL NO.	DESCRIPTION
7089	Nozzle Service Kit

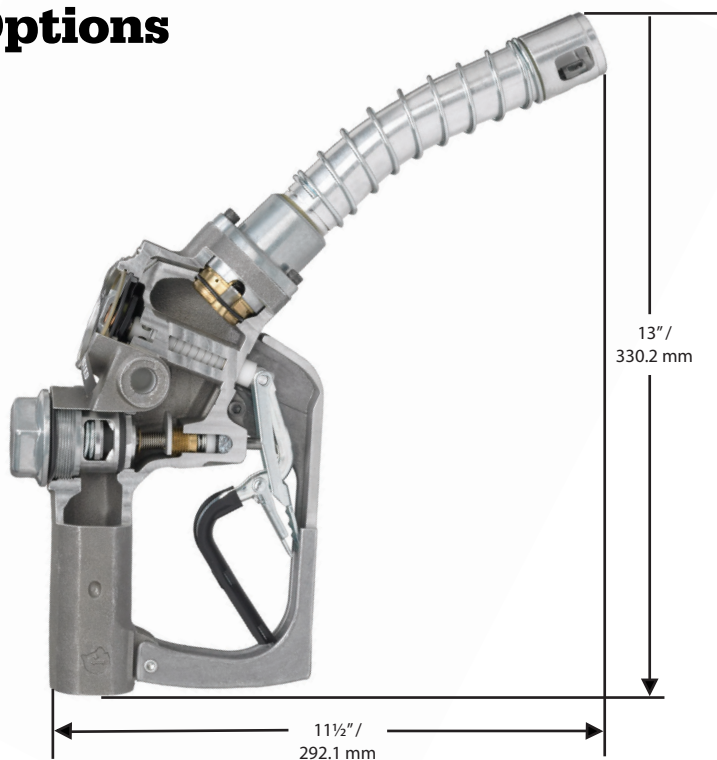

Guards

MODEL NO.	DESCRIPTION
4740	Full Grip Guard
7352	POPD™ S Full Grip Guard
8186	POPD™ H Full Grip Guard
5516	Full Grip Reguard
8194	POPD™ S Full Grip Reguard
8193	POPD™ H Full Grip Reguard
8167	POPD™ S Mate Guard
8168	POPD™ H Mate Guard
1808	Waffle Splash Guard
8177	POPD™ EZS Nozzle Guard
8178	POPD™ EZH Nozzle Guard
6628	POPD™ S Clear Cover
7999	POPD™ H Clear Cover
5494	Lever Cover



MADE IN THE U.S.A.





Husky

GENERAL FUELING PRODUCTS

Vapor Recovery Nozzles

V Nozzles



Husky V Nozzle is for Stage II installations using Balance System Vapor Recovery.

- The Husky V fits existing conventional dispensers. Conversions to Balance Vapor Recovery can be faster, easier and less costly.
- Nozzle is equipped with mechanical interlock that shuts off the nozzle if it falls from the fill tank.
- Nozzle has automatic shut-off so can be used for self-service, full-service, and unattended stations.
- Vapor valve is in the nozzle body, not in the spout.
- Aluminum casting provides a lightweight, easier to handle nozzle.
- Easy and inexpensive to maintain due to the one-piece bellow, the uncluttered spout, and the simple, single bellow clamp.
- The bellow is more flexible and provides greater resistance to cuts, scuffing and damage. It has the lightest "force" needed to insert/seal of any bellows nozzle.
- *Streamshaper™* reduces turbulence for a straighter fuel flow and less splash back spillage.



Short Spout Nozzles

MODEL NO.	DESCRIPTION	SHIPPING WEIGHT LBS (KG)
5010	New with Three Notch Hold Open Clip	3.9 (1.7)
5020	New without Hold Open Clip	3.9 (1.7)
5010100	New with Three Notch Hold Open Clip, POPD™ Full Grip Guard and Sightglass	4.2 (1.9)
5410	Rebuilt with Three Notch Hold Open Clip	4.2 (1.9)
5420	Rebuilt without Hold Open Clip	4.2 (1.9)

Long Spout Nozzles

MODEL NO.	DESCRIPTION	SHIPPING WEIGHT LBS (KG)
5210	New with Three Notch Hold Open Clip	4.0 (1.8)
5220	New without Hold Open Clip	4.0 (1.8)
5450	Rebuilt with Three Notch Hold Open Clip	4.0 (1.8)
5460	Rebuilt without Hold Open Clip	4.0 (1.8)

Construction

Body	Aluminum
Seals	Fluorocarbon
Packing	Fiber Reinforced Teflon
Lever	One piece contoured steel with hard plastic cover
Inlet	1 1/8" x 12

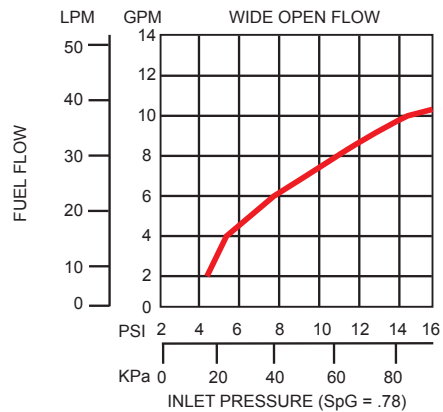

Husky V Nozzle is for Stage II installations using Balance System Vapor Recovery.

Dimensions and System Options

Safe-T-Breaks®

MODEL NO.	DESCRIPTION
3360VR	Reconnectable Safe-T-Break®
5900	Non-Reconnectable Safe-T-Break®

Spouts

MODEL NO.	DESCRIPTION
5800-01	Complete Unleaded Assembly Kit - Short
5802-01	Unleaded Spout - Short
5900-01	Complete Unleaded Assembly Kit - Long
5902-01	Unleaded Spout - Long

Pressure/Vacuum Vents

MODEL NO.	DESCRIPTION
4620	2" Slip-On Pressure Vacuum Vent
4885	2" Thread-On Pressure Vacuum Vent - NPTF
5885	2" Thread-On Pressure Vacuum Vent with internal screen - NPT

Accessories, Testing and Maintenance

MODEL NO.	DESCRIPTION
7089	Nozzle Service Kit
3593	Hold Open Clip Kit
3364	Bellow Clamp Tool
0397	Unleaded Spout Gauge
5827	Balance Vapor Recovery Flo-Equalizer™
5801	Short Bellow Assembly with Clamp
5803	Short Bellow Spring Assembly
5901	Long Bellow Assembly with Clamp
5903	Long Bellow Spring Assembly
2879	Bellow Clamp

Guards

MODEL NO.	DESCRIPTION
5950	Full Grip Guard
6650	POPD™ S Full Grip Guard
8182	POPD™ H Full Grip Guard
4190	Full Grip Reguard
7215	POPD™ S Full Grip Reguard
8189	POPD™ H Full Grip Reguard
6628	POPD™ S Clear Cover
7999	POPD™ H Clear Cover
5494	Lever Cover



Husky V EVRLX Nozzle is an enhanced vapor recovery nozzle designed for Balance Stage II installations.

- Unique Drip Less Spout that meets the CARB TP-201.2D requirement.
- The nozzle is equipped with a built-in liquid extraction (LX) feature that requires a special hose with LEFT HAND THREADS for simple thread on connection.
- LX design allows higher flow rates due to lower restriction.
- Reduces potential liquid accumulation in vapor hose by eliminating the hose venturi.
- The bellow provides greater resistance to cuts, scuffing and damage. It has the lightest “force” needed to insert / seal of any balance nozzle.
- Nozzle is equipped with mechanical interlock that shuts off the nozzle if it falls from the fill tank.
- Vapor valve is in the body, not in the spout.
- *StreamShaper™* reduces turbulence for straighter fuel flow and less splash back spillage.
- Easy and inexpensive to maintain due to the one-piece bellow, the uncluttered spout, and the simple, single bellow clamp.
- Conversions to Stage II can be faster and less costly because this nozzle will fit most existing dispensers.
- Aluminum casting and design provides a light-weight, easier to handle nozzle.



New Nozzles

MODEL NO.	DESCRIPTION	SHIPPING WEIGHT LBS (KG)
593004	with Three Notch Hold Open Clip	4.1 (1.8)
593070	with Three Notch Hold Open Clip and 8' Goodyear® Hose	10.2 (4.6)
593008	without Hold Open Clip	4.1 (1.8)
593071	without Hold Open Clip, with 8' Goodyear® Hose	10.2 (4.6)

Rebuilt Nozzles

MODEL NO.	DESCRIPTION	SHIPPING WEIGHT LBS (KG)
593404	with Three Notch Hold Open Clip	4.1 (1.8)
593470	with Three Notch Hold Open Clip and 8' Goodyear® Hose	10.2 (4.6)
593408	without Hold Open Clip	3.7 (1.6)
593471	without Hold Open Clip, with 8' Goodyear® Hose	10.2 (4.6)

Construction

Body	One piece die cast aluminum
Seals	Fluorocarbon
Packing	Teflon impregnated graphite
Lever	One piece contoured steel
Inlet	1 7/8" x 12 Left hand threads (requires special LX hose)

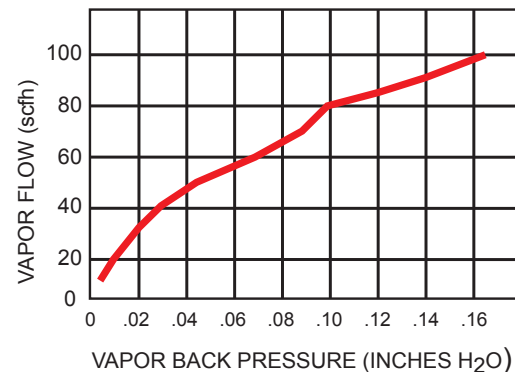
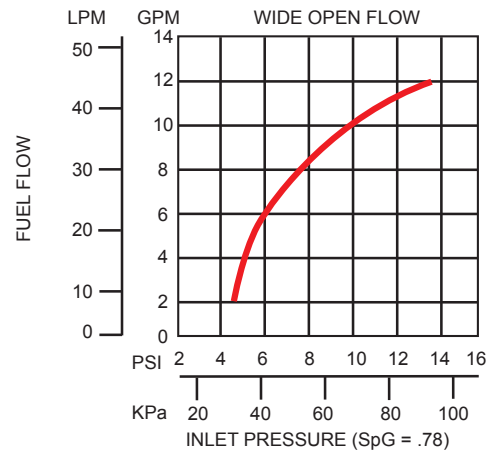

California Environmental Protection Agency
AIR RESOURCES BOARD
 Pending

**Husky**

GENERAL FUELING PRODUCTS



EVRLX Nozzles

Husky V EVRLX Nozzle is an enhanced vapor recovery nozzle designed for Balance Stage II installations.

Dimensions and System Options

Safe-T-Breaks®

MODEL NO.	DESCRIPTION
3360VR	Reconnectable Safe-T-Break®
5900	Non-Reconnectable Safe-T-Break®

Spouts

MODEL NO.	DESCRIPTION
6030	Complete Unleaded Assembly Kit
6321	Unleaded Spout

Pressure/Vacuum Vents

MODEL NO.	DESCRIPTION
4620	2" Slip-On Pressure Vacuum Vent
4885	2" Thread-On Pressure Vacuum Vent - NPTF
5885	2" Thread-On Pressure Vacuum Vent with internal screen - NPTF

Accessories, Testing and Maintenance

MODEL NO.	DESCRIPTION
7089	Nozzle Service Kit
3593	Hold Open Clip Kit
3364	Bellow Clamp Tool
0397	Unleaded Spout Gauge
5801	Short Bellow Assembly with Clamp
5803	Short Bellow Spring Assembly
2879	Bellow Clamp
5827	Balance Vapor Recovery Flo-Equalizer™
6188	Goodyear® Premier LX 8' Hose with Left Hand Threads

Guards

MODEL NO.	DESCRIPTION
5950	Full Grip Guard
6650	POPD™ Full Grip Guard
4190	Full Grip Reguard
7215	POPD™ Full Grip Reguard
6628	POPD™ Clear Cover
5494	Lever Guard



**Husky**

GENERAL FUELING PRODUCTS

V3 Nozzles

Vacuum assist, automatic shut-off nozzle for full-service, self-service and unattended stations.

Dimensions and System Options

Safe-T-Breaks®

MODEL NO.	DESCRIPTION
4034	Reconnectable Safe-T-Break®
4034A	Reconnectable Safe-T-Break® - Atex
6210	Non-Reconnectable Safe-T-Break®
5134A	Non-Reconnectable Safe-T-Break® - Atex

Swivels

MODEL NO.	DESCRIPTION
4605	Inverted Vapor Assist Swivel

Spouts

MODEL NO.	DESCRIPTION
6289	Complete Spout Assembly Kit - Unleaded
6389	Unleaded Spout

Pressure/Vacuum Vents

MODEL NO.	DESCRIPTION
4620	2" Slip-On Pressure Vacuum Vent
4885	2" Thread-On Pressure Vacuum Vent - NPTF
5885	2" Thread-On Pressure Vacuum Vent with internal screen - NPT

Accessories, Testing and Maintenance

MODEL NO.	DESCRIPTION
7089	Nozzle Service Kit
3593	Hold Open Clip Kit
0397	Unlead Spout Gauge
4360	Air/Liquid Spout Adaptor
5260	Tool for dry Air/Liquid Test
5233	O-ring Kit
5837	Vapor Assist Flo-Equalizer™

Guards

MODEL NO.	DESCRIPTION
5170	Full Grip Guard
5169	Full Grip Reguard
6955	Waffle Splash Guard
5494	Lever Guard



MADE IN THE U.S.A.

V34 Nozzles



Pressure activated, automatic shut-off vacuum assist nozzle for full-service, self-service and unattended stations.

- V34 Nozzle shuts off when
 - the pump shuts off.
 - the gas tank is full.
 - the lever is opened before
 - the pump is turned on.
 - the leak detector has not
 - completed the test cycle.
- Strong vapor valve in the nozzle that is mechanically operated by the on-off action of the nozzle's lever.
- *Streamshaper™* reduces turbulence for straighter fuel flow and less splash back spillage.
- Husky vapor return line is an internal part of the body casting, thus eliminating potential vapor leak points and fugitive evaporative emissions from the fuel remaining in the vapor path of the hose.
- Nozzle is equipped with a unique Flo-Stop™ device that shuts off the nozzle if it falls from the fill tank or raises above the horizontal.
- Uses conventional spout with spout ring and soft vapor escape guard.
- Vapor assist achieved at the body end of the spout where a vapor ring catches emissions.
- Nozzle spout is covered by a one year warranty.



New Unleaded Nozzles

MODEL NO.	DESCRIPTION	SHIPPING WEIGHT LBS (KG)
6250041	with Three Notch Hold Open Clip	4.0 (1.8)
6250041A	with Three Notch Hold Open Clip - Atex	4.0 (1.8)
6250241	with Three Notch Hold Open Clip and Sightglass	4.0 (1.8)
6250941	with Three Notch Hold Open Clip and POPD™ Full Grip Guard	4.0 (1.8)
62501001	with Three Notch Hold Open Clip, POPD™ Full Grip Guard and Sightglass	4.0 (1.8)
6250431	with Single Notch Hold Open Clip	4.0 (1.8)
6250891	with Single Notch Hold Open Clip and POPD™ Full Grip Guard	4.0 (1.8)
6250081	without Hold Open Clip	4.0 (1.8)

Rebuilt Unleaded Nozzles

MODEL NO.	DESCRIPTION	SHIPPING WEIGHT LBS (KG)
6254041	with Three Notch Hold Open Clip	3.7 (1.6)
6254241	with Three Notch Hold Open Clip and Sightglass	3.7 (1.6)
6254081	without Hold Open Clip	3.7 (1.6)

Construction

Body	One piece die cast aluminum
Seals	Fluorocarbon
Packing	Fiber reinforced Teflon
Lever	One piece contoured steel with hard plastic cover
Inlet	M34 x 1.5

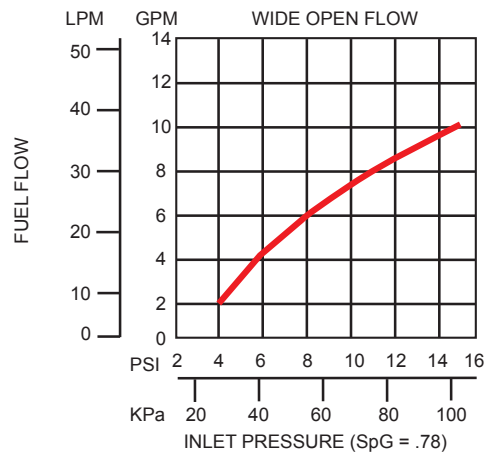
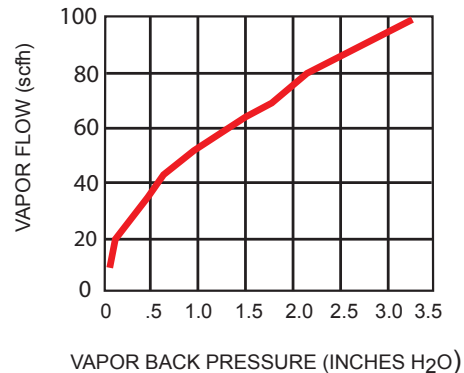

II 1 G
EN13012 Type 1



AIR RESOURCES BOARD

**Husky**

GENERAL FUELING PRODUCTS

V34 Nozzles

Pressure activated, automatic shut-off vacuum assist nozzle for full-service, self-service and unattended stations.

Dimensions and System Options

Safe-T-Breaks®

MODEL NO.	DESCRIPTION
4034	Reconnectable Safe-T-Break®
4034A	Reconnectable Safe-T-Break® - Atex
6210	Non-Reconnectable Safe-T-Break®
5134A	Non-Reconnectable Safe-T-Break® - Atex

Swivels

MODEL NO.	DESCRIPTION
4605	Inverted Vapor Assist Swivel

Spouts

MODEL NO.	DESCRIPTION
6291	Complete Spout Assembly Kit - Unleaded
6391	Unleaded Spout

Pressure/Vacuum Vents

MODEL NO.	DESCRIPTION
4620	2" Slip-On Pressure Vacuum Vent
4885	2" Thread-On Pressure Vacuum Vent - NPTF
5885	2" Thread-On Pressure Vacuum Vent with internal screen - NPTF

Accessories, Testing and Maintenance

MODEL NO.	DESCRIPTION
7089	Nozzle Service Kit
3593	Hold Open Clip Kit
6497	VSG Clamp Tool
0397	Unlead Spout Gauge
4360	Air/Liquid Spout Adaptor
5260	Tool for dry Air/Liquid Test
5233	O-ring Kit
5837	Vapor Assist Flo-Equalizer™



Guards

MODEL NO.	DESCRIPTION
4000	Vapor Splash Guard (VSG) with Clamp
4039	Vapor Splash Guard Clamp
6951	Full Grip Guard
6660	POPD™ S Full Grip Guard
8184	POPD™ H Full Grip Guard
4231	Full Grip Reguard
7220	POPD™ S Full Grip Reguard
8191	POPD™ H Full Grip Reguard
6628	POPD™ S Clear Cover
7999	POPD™ H Clear Cover
5494	Lever Guard



MADE IN THE U.S.A.



V34 Coax Nozzles



Pressure activated, automatic shut-off vacuum assist nozzle for full-service, self-service and unattended stations.

- V34 Nozzle shuts off when
 - the pump shuts off.
 - the gas tank is full.
 - the lever is opened before the pump is turned on.
 - the leak detector has not completed the test cycle.
- Strong vapor valve in the nozzle that is mechanically operated by the on-off action of the nozzle's lever.
- Nozzle is equipped with a unique Flo-Stop™ device that shuts off the nozzle if it falls from the fill tank or raises above the horizontal.
- Uses a coaxial spout with spout ring and has large vapor-capturing holes at the end of the spout.
- Nozzle spout is covered by a one year warranty.

New Unleaded Nozzles

MODEL NO.	DESCRIPTION	SHIPPING WEIGHT LBS (KG)
6200041	with Coaxial Spout and Three Notch Hold Open Clip	4.0 (1.8)

Construction

Body	One piece die cast aluminum
Seals	Fluorocarbon
Packing	Fiber reinforced Teflon
Lever	One piece contoured steel with hard plastic cover
Inlet	M34 x 1.5

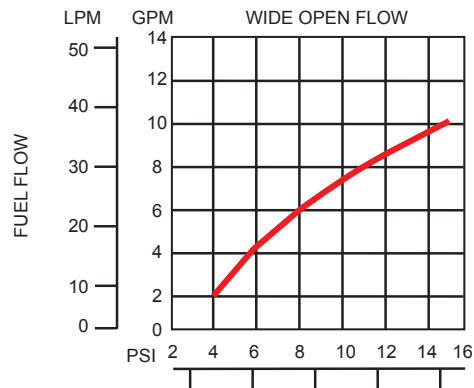
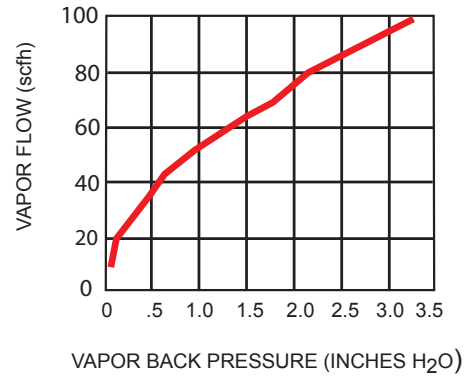

California Environmental Protection Agency
AIR RESOURCES BOARD

**Husky**

GENERAL FUELING PRODUCTS

V34 Coax Nozzles

Pressure activated, automatic shut-off vacuum assist nozzle for full-service, self-service and unattended stations.

Dimensions and System Options

Safe-T-Breaks®

MODEL NO.	DESCRIPTION
4034	Reconnectable Safe-T-Break®
6210	Non-Reconnectable Safe-T-Break®

Swivels

MODEL NO.	DESCRIPTION
4605	Inverted Vapor Assist Swivel

Spouts

MODEL NO.	DESCRIPTION
8642	Complete Spout Assembly Kit - Unleaded

Pressure/Vacuum Vents

MODEL NO.	DESCRIPTION
4620	2" Slip-On Pressure Vacuum Vent
4885	2" Thread-On Pressure Vacuum Vent - NPTF
5885	2" Thread-On Pressure Vacuum Vent with internal screen - NPTF

Accessories, Testing and Maintenance

MODEL NO.	DESCRIPTION
7089	Nozzle Service Kit
3593	Hold Open Clip Kit
6497	VSG Clamp Tool
0397	Unlead Spout Gauge
4360	Air/Liquid Spout Adaptor
5260	Tool for dry Air/Liquid Test
5233	O-ring Kit
5837	Vapor Assist Flo-Equalizer™

Guards

MODEL NO.	DESCRIPTION
4000	Vapor Splash Guard (VSG) with Clamp
4039	Vapor Splash Guard Clamp
6951	Full Grip Guard
6660	POPD™ S Full Grip Guard
8184	POPD™ H Full Grip Guard
4231	Full Grip Reguard
7220	POPD™ S Full Grip Reguard
8191	POPD™ H Full Grip Reguard
6628	POPD™ S Clear Cover
7999	POPD™ H Clear Cover
5494	Lever Guard

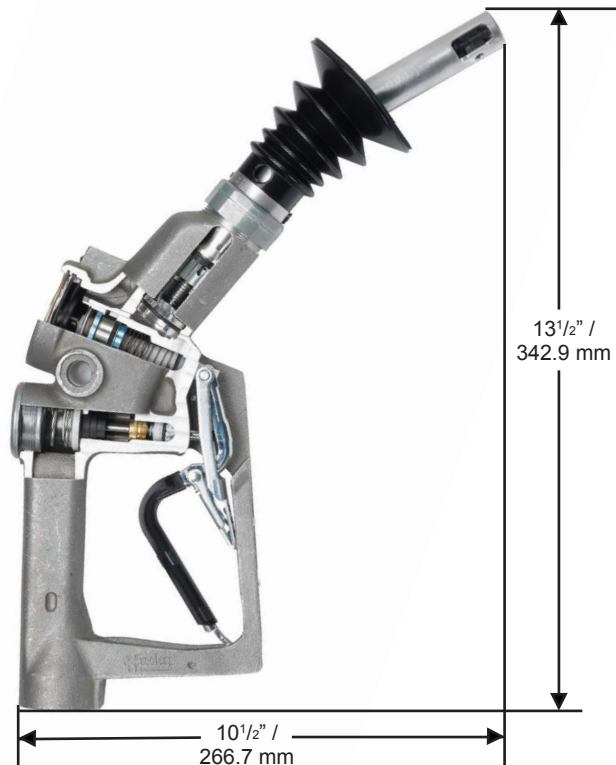

MADE IN THE U.S.A.

V34 DP Nozzles



Pressure activated, automatic shut-off vacuum assist nozzle for full-service, self-service and unattended stations.

- V34 nozzle shuts off when the gas tank is full.
- Strong vapor valve in the nozzle that is mechanically operated by the on-off action of the nozzle's lever.
- *Streamshaper™* reduces turbulence for straighter fuel flow and less splash back spillage.
- Husky vapor return line is an internal part of the body casting, thus eliminating potential vapor leak points and fugitive evaporative emissions from the fuel remaining in the vapor path of the hose.
- Nozzle is equipped with a unique Flo-Stop™ device that shuts off the nozzle if it falls from the fill tank or raises above the horizontal.
- Uses conventional spout with spout ring and soft vapor escape guard.
- Vapor assist achieved at the body end of the spout where a vapor ring catches emissions.
- Nozzle spout is covered by a one year warranty.



New Unleaded Nozzles

MODEL NO.	DESCRIPTION	SHIPPING WEIGHT LBS (KG)
6252041	with Double Poppet and Two Notch Hold Open Clip	4.0 (1.8)
6252041A*	with Double Poppet and Two Notch Hold Open Clip - Atex	4.0 (1.8)
6252931A	with High Flow Double Poppet and Two Notch Hold Open Clip - Atex	4.0 (1.8)

Rebuilt Unleaded Nozzles

MODEL NO.	DESCRIPTION	SHIPPING WEIGHT LBS (KG)
6254041	with Three Notch Hold Open Clip	3.7 (1.6)
6254241	with Three Notch Hold Open Clip and Sightglass	3.7 (1.6)
6254081	without Hold Open Clip	3.7 (1.6)

Construction

Body	Aluminum
Seals	Fluorocarbon
Packing	Fiber reinforced Teflon
Lever	One piece contoured steel
Inlet	M34 x 1.5

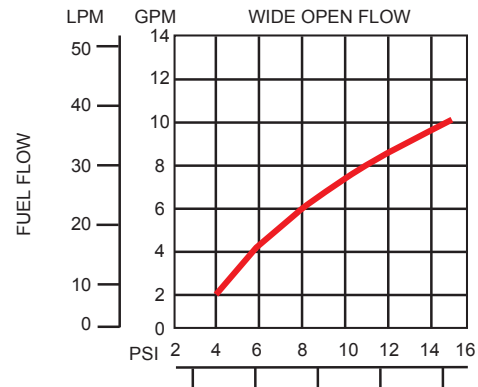
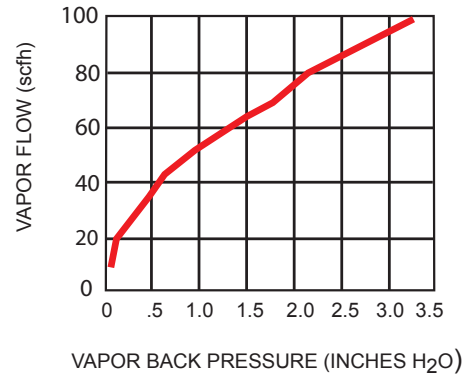

**Husky**

GENERAL FUELING PRODUCTS

V34 DP Nozzles

Pressure activated, automatic shut-off vacuum assist nozzle for full-service, self-service and unattended stations.

Dimensions and System Options

Safe-T-Breaks®

MODEL NO.	DESCRIPTION
4034	Reconnectable Safe-T-Break®
6210	Non-Reconnectable Safe-T-Break®

Swivels

MODEL NO.	DESCRIPTION
4605	Inverted Vapor Assist Swivel

Spouts

MODEL NO.	DESCRIPTION
6291	Complete Spout Assembly Kit - Unleaded
6391	Unleaded Spout

Pressure/Vacuum Vents

MODEL NO.	DESCRIPTION
4620	2" Slip-On Pressure Vacuum Vent
4885	2" Thread-On Pressure Vacuum Vent - NPTF
5885	2" Thread-On Pressure Vacuum Vent with internal screen - NPTF

Accessories, Testing and Maintenance

MODEL NO.	DESCRIPTION
7089	Nozzle Service Kit
3593	Hold Open Clip Kit
6497	VSG Clamp Tool
0397	Unleaded Spout Gauge
4360	Air/Liquid Spout Adaptor
5260	Tool for dry Air/Liquid Test
5233	O-ring Kit
5837	Vapor Assist Flo-Equalizer™

Guards

MODEL NO.	DESCRIPTION
4000	Vapor Splash Guard (VSG) w/ Clamp
4039	VSG Clamp
6951	Full Grip Guard
6660	POPD™ S Full Grip Guard
8184	POPD™ H Full Grip Guard
4231	Full Grip Reguard
7220	POPD™ S Full Grip Reguard
8191	POPD™ H Full Grip Reguard
6628	POPD™ S Clear Cover
7999	POPD™ H Clear Cover
5494	Lever Cover

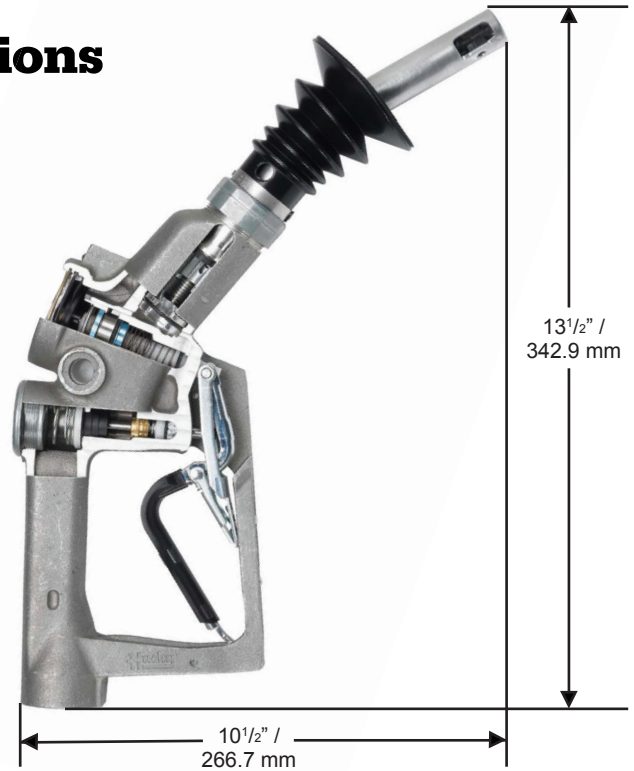

MADE IN THE U.S.A.



V34 ORVR Nozzles



Pressure activated, automatic shut-off vacuum assist nozzle for full-service, self-service and unattended stations.

- V34 Nozzle shuts off when
 - the pump shuts off.
 - the gas tank is full.
 - the lever is opened before the pump is turned on.
 - the leak detector has not completed the test cycle.
- Nozzle designed for the Veeder-Root® 900301 and VST Enviro-Loc™ primary hose with ORVR valve.
- Strong vapor valve in the nozzle that is mechanically operated by the on-off action of the nozzle's lever.
- Nozzle is equipped with a unique Flo-Stop™ device that shuts off the nozzle if it falls from the fill tank or raises above the horizontal.
- StreamShaper™ reduces turbulence for straighter flow and less splash back spillage.
- Uses conventional spout with spout ring and soft vapor escape guard.
- Husky vapor return line is an internal part of the body casting, thus eliminating potential vapor leak points and fugitive evaporative emissions from the fuel remaining in the vapor path of the hose.
- Vapor assist achieved at the body end of the spout where a vapor ring catches emissions.



New Unleaded Nozzles

MODEL NO.	DESCRIPTION	SHIPPING WEIGHT LBS (KG)
6536041	with Two Notch Hold Open Clip	4.0 (1.8)

Construction

Body	Aluminum
Seals	Fluorocarbon
Packing	Fiber Reinforced Teflon
Lever	One Piece Contoured Steel
Inlet	1 1/4" - 18 Thread

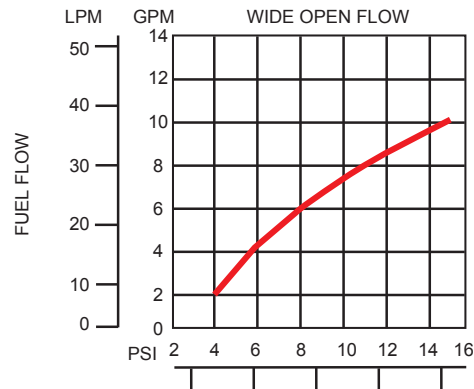
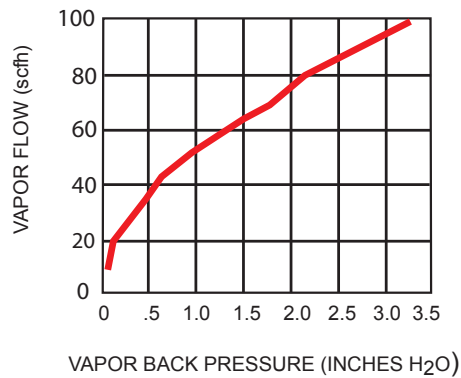

**Husky**

GENERAL FUELING PRODUCTS

V34 ORVR Nozzles

Pressure activated, automatic shut-off vacuum assist nozzle for full-service, self-service and unattended stations.

Dimensions and System Options

Safe-T-Breaks®

MODEL NO.	DESCRIPTION
6560	Reconnectable ORVR Safe-T-Break®

Swivels

MODEL NO.	DESCRIPTION
4605	Inverted Vapor Assist Swivel

Spouts

MODEL NO.	DESCRIPTION
6663	Complete Spout Assembly Kit - Unleaded
6391	Unleaded Spout

Pressure/Vacuum Vents

MODEL NO.	DESCRIPTION
4620	2" Slip-On Pressure Vacuum Vent
4885	2" Thread-On Pressure Vacuum Vent - NPTF
5885	2" Thread-On Pressure Vacuum Vent with internal screen - NPTF

Accessories, Testing and Maintenance

MODEL NO.	DESCRIPTION
7089	Nozzle Service Kit
3593	Hold Open Clip Kit
6497	VSG Clamp Tool
4360	A/L Spout Adaptor
5260	Tool For Dry A/L Test
5233	O-ring Replacement Kit
5837	Vapor Assist Flo-Equalizer™

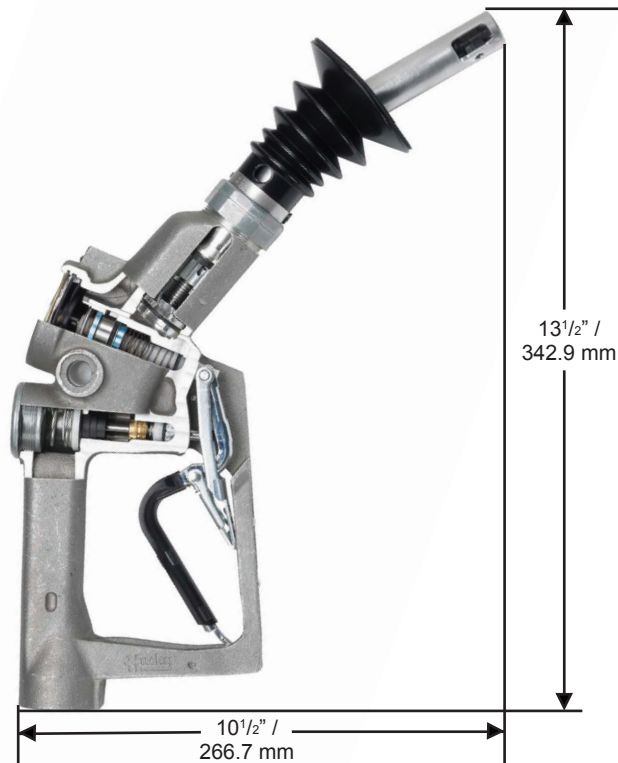

Guards

MODEL NO.	DESCRIPTION
6656	ORVR Vapor Splash Guard (VSG) with Clamp
4039	Vapor Splash Guard Clamp
6951	Full Grip Guard
6660	POPD™ S Full Grip Guard
8184	POPD™ H Full Grip Guard
4231	Full Grip Reguard
7220	POPD™ S Full Grip Reguard
8191	POPD™ H Full Grip Reguard
6628	POPD™ S Clear Cover
7999	POPD™ H Clear Cover
5494	Lever Guard



MADE IN THE U.S.A.



V34i Nozzles



Automatic shut-off vacuum assist nozzle for full-service, self-service and unattended stations.

- V34i Nozzle shuts off when the gas tank is full.
- Strong vapor valve in the nozzle that is mechanically operated by the on-off action of the nozzle's lever.
- Nozzle is equipped with a unique Flo-Stop™ device that shuts off the nozzle if it falls from the fuel tank or raises above the horizontal.
- StreamShaper™ reduces turbulence for straighter flow and less splash back spillage.
- Uses conventional spout with spout ring and soft vapor escape guard.
- Husky vapor return line is an internal part of the body casting, thus eliminating potential vapor leak points and fugitive evaporative emissions from the fuel remaining in the vapor path of the hose.
- Vapor assist achieved at the body end of the spout where a vapor ring catches emissions.
- Nozzle spout is covered by a one year warranty.



New Unleaded Nozzles

MODEL NO.	DESCRIPTION	SHIPPING WEIGHT LBS (KG)
6670041	with Two Notch Hold Open Clip	4.0 (1.8)
6670041A	with Two Notch Hold Open Clip - Atex	4.0 (1.8)

Construction

Body	Aluminum
Seals	Fluorocarbon
Packing	Double o-ring seal protected by fiber reinforced Teflon
Lever	One piece contoured steel with hard plastic cover
Inlet	M34 x 1.5

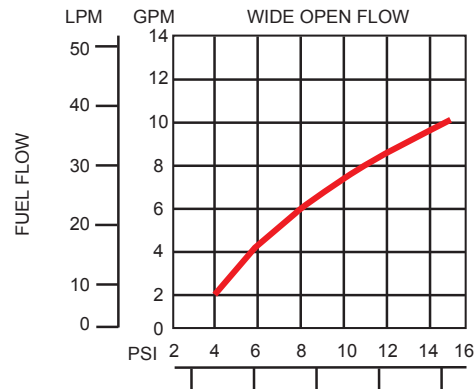
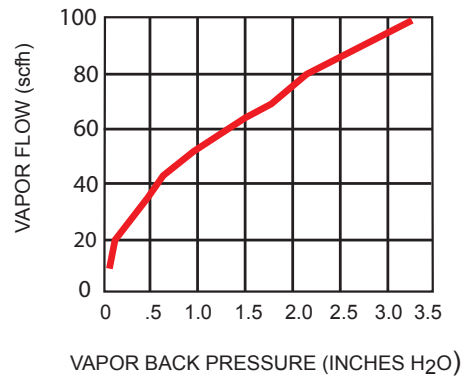

**Husky**

GENERAL FUELING PRODUCTS

V34i Nozzles

Automatic shut-off vacuum assist nozzle for full-service, self-service and unattended stations.

Dimensions and System Options

Safe-T-Breaks®

MODEL NO.	DESCRIPTION
4034	Reconnectable Safe-T-Break®
4034A	Reconnectable Safe-T-Break® - Atex
6210	Non-Reconnectable Safe-T-Break®
5134A	Non-Reconnectable Safe-T-Break® - Atex

Swivels

MODEL NO.	DESCRIPTION
4605	Inverted Vapor Assist Swivel

Pressure/Vacuum Vents

MODEL NO.	DESCRIPTION
4620	2" Slip-On Pressure Vacuum Vent
4885	2" Thread-On Pressure Vacuum Vent - NPTF
5885	2" Thread-On Pressure Vacuum Vent with internal screen - NPTF

Accessories, Testing and Maintenance

MODEL NO.	DESCRIPTION
7089	Nozzle Service Kit
3593	Hold Open Clip Kit
0397	Unleaded Spout Gauge
5233	O-ring Kit
5837	Vapor Assist Flo-Equalizer™

Guards

MODEL NO.	DESCRIPTION
6951	Full Grip Guard
6660	POPD™ S Full Grip Guard
8184	POPD™ H Full Grip Guard
4231	Full Grip Reguard
7220	POPD™ S Full Grip Reguard
8191	POPD™ H Full Grip Reguard
6628	POPD™ S Clear Cover
7999	POPD™ H Clear Cover
5494	Lever Guard

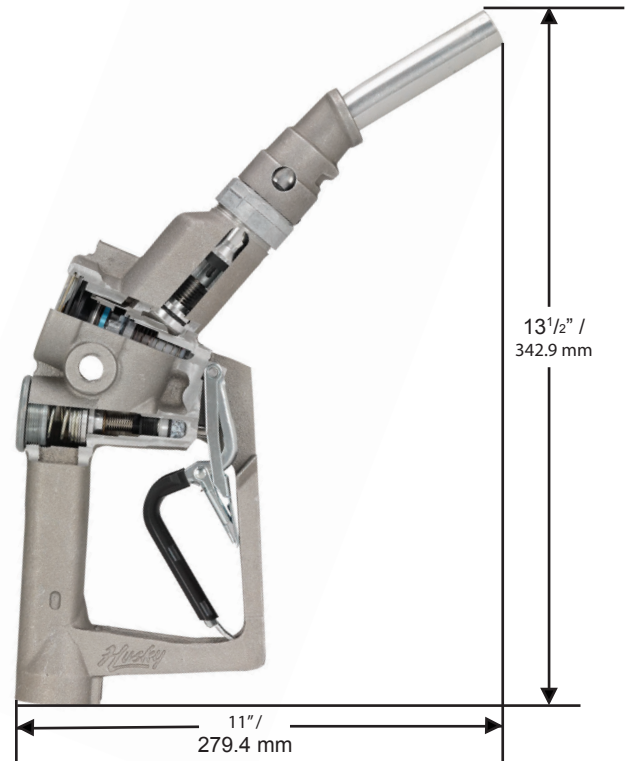

MADE IN THE U.S.A.

V34i DP Nozzles



Automatic shut-off vacuum assist nozzle for full-service, self-service and unattended stations.

- V34i nozzle shuts off when the gas tank is full.
- Strong vapor valve in the nozzle that is mechanically operated by the on-off action of the nozzle's lever.
- *StreamShaper™* reduces turbulence for straighter flow and less splash back spillage.
- Nozzle is equipped with a double poppet for precise, slow-flow, to-the-penny dispensing.
- Husky vapor return line is an internal part of the body casting, thus eliminating potential vapor leak points and fugitive evaporative emissions from the fuel remaining in the vapor path of the hose.
- Uses conventional spout without spout ring and aluminum vapor escape guard.
- Vapor assist is achieved at the body end of the spout where a vapor ring captures emissions.
- Nozzle spout is covered by a one year warranty.



New Unleaded Nozzles

MODEL NO.	DESCRIPTION	SHIPPING WEIGHT LBS (KG)
7321041A*	with Double Poppet, and Three Notch Hold Open Clip - Atex	4.0 (1.8)
7320041A*	with High Flow Double Poppet, and Three Notch Hold Open Clip - Atex	4.0 (1.8)
7320101A*	with High Flow Double Poppet, without Three Notch Hold Open Clip - Atex	4.0 (1.8)

Construction

Body	Aluminum
Seals	Fluorocarbon
Packing	Double o-ring seal protected by fiber reinforced Teflon
Lever	One piece contoured steel with hard plastic cover
Inlet	M34 x 1.5

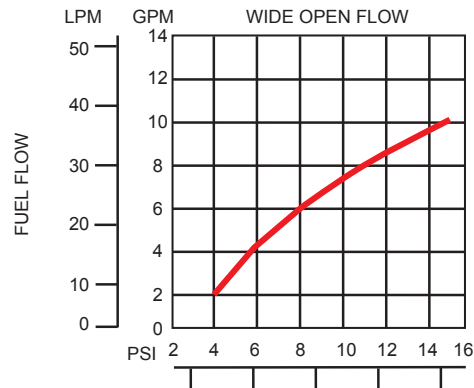
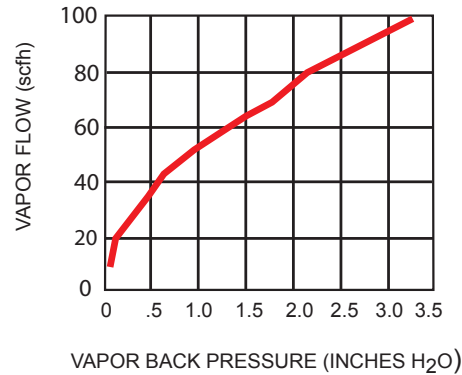



Automatic shut-off vacuum assist nozzle for full-service, self-service and unattended stations.

Dimensions and System Options

Safe-T-Breaks®

MODEL NO.	DESCRIPTION
4034	Reconnectable Safe-T-Break®
6210	Non-Reconnectable Safe-T-Break®

Swivels

MODEL NO.	DESCRIPTION
4605	Inverted Vapor Assist Swivel

Pressure/Vacuum Vents

MODEL NO.	DESCRIPTION
4620	2" Slip-On Pressure Vacuum Vent
4885	2" Thread-On Pressure Vacuum Vent - NPTF
5885	2" Thread-On Pressure Vacuum Vent with internal screen - NPTF

Accessories, Testing and Maintenance

MODEL NO.	DESCRIPTION
7089	Nozzle Service Kit
3593	Hold Open Clip Kit
5233	O-ring Replacement Kit
0397	Unleaded Spout Gauge
5837	Vapor Assist Flo-Equalizer™

Guards

MODEL NO.	DESCRIPTION
6951	Full Grip Guard
6660	POPD™ S Full Grip Guard
8184	POPD™ H Full Grip Guard
4231	Full Grip Reguard
7220	POPD™ S Full Grip Reguard
8191	POPD™ H Full Grip Reguard
6628	POPD™ S Clear Cover
7999	POPD™ H Clear Cover
5494	Lever Cover

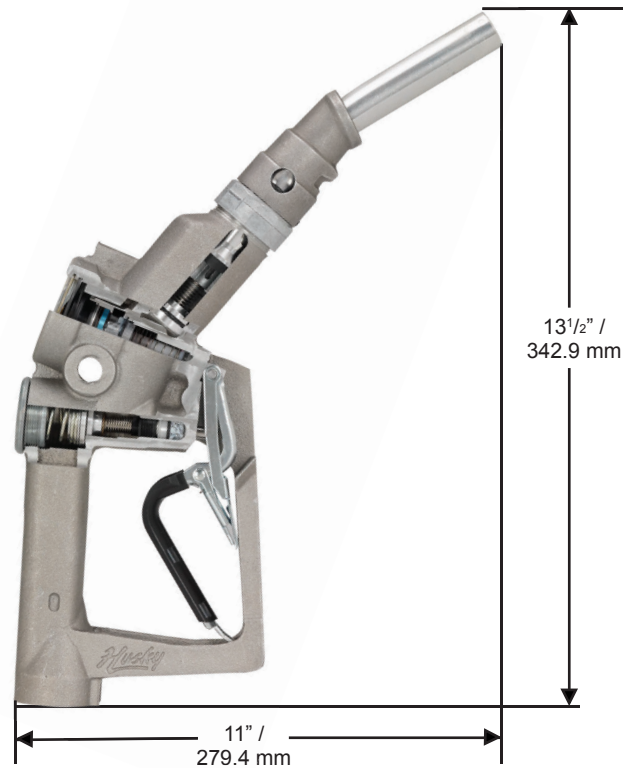



Automatic shut-off vacuum assist nozzle for full-service, self-service and unattended stations.

- V34i nozzle shuts off when the gas tank is full.
- Strong vapor valve in the nozzle that is mechanically operated by the on-off action of the nozzle's lever.
- *StreamShaper™* reduces turbulence for straighter flow and less splash back spillage.
- Nozzle is equipped with a double poppet for precise, slow-flow, to-the-penny dispensing.
- Husky vapor return line is an internal part of the body casting, thus eliminating potential vapor leak points and fugitive evaporative emissions from the fuel remaining in the vapor path of the hose.
- Uses conventional spout without spout ring and aluminum vapor escape guard.
- Vapor assist is achieved at the body end of the spout where a vapor ring captures emissions.
- Nozzle spout is covered by a one year warranty.

Model 8686021

- Nozzle is equipped with a unique Flo-Stop™ device that shuts off the nozzle if it falls from the fill tank or raises above the horizontal.



New Unleaded Nozzles

MODEL NO.	DESCRIPTION	SHIPPING WEIGHT LBS (KG)
8686021	with Double Poppet, Cold Weather Seals and Three Notch Hold Open Clip	4.0 (1.8)
8686041	with Double Poppet, Cold Weather Seals, Flo-Stop™ and Three Notch Hold Open Clip	4.0 (1.8)

Construction

Body	Aluminum
Seals	Fluorocarbon
Packing	Double o-ring seal protected by fiber reinforced Teflon
Lever	One piece contoured steel with hard plastic cover
Inlet	M34 x 1.5

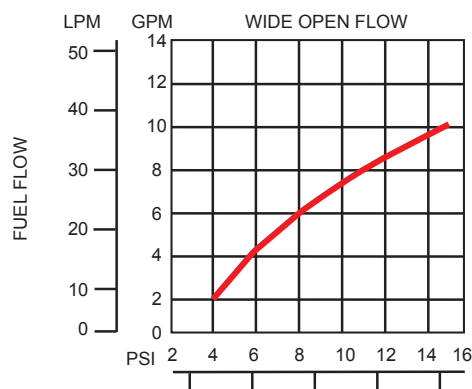
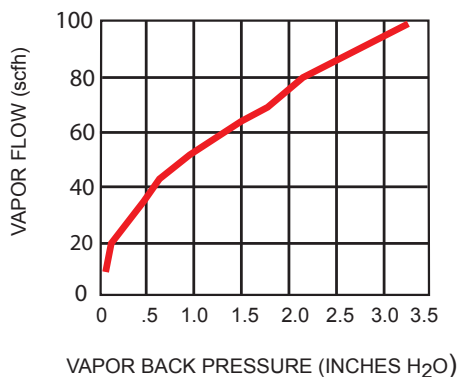

**Husky**

GENERAL FUELING PRODUCTS

V34i DP & CW Nozzles

Automatic shut-off vacuum assist nozzle for full-service, self-service and unattended stations.

Dimensions and System Options

Safe-T-Breaks®

MODEL NO.	DESCRIPTION
4034	Reconnectable Safe-T-Break®
6210	Non-Reconnectable Safe-T-Break®

Swivels

MODEL NO.	DESCRIPTION
4605	Inverted Vapor Assist Swivel

Pressure/Vacuum Vents

MODEL NO.	DESCRIPTION
4620	2" Slip-On Pressure Vacuum Vent
4885	2" Thread-On Pressure Vacuum Vent - NPTF
5885	2" Thread-On Pressure Vacuum Vent with internal screen - NPTF

Accessories, Testing and Maintenance

MODEL NO.	DESCRIPTION
7089	Nozzle Service Kit
3593	Hold Open Clip Kit
5233	O-ring Replacement Kit
0397	Unleaded Spout Gauge
5837	Vapor Assist Flo-Equalizer™

Guards

MODEL NO.	DESCRIPTION
6951	Full Grip Guard
6660	POPD™ S Full Grip Guard
8184	POPD™ H Full Grip Guard
4231	Full Grip Reguard
7220	POPD™ S Full Grip Reguard
8191	POPD™ H Full Grip Reguard
6628	POPD™ S Clear Cover
7999	POPD™ H Clear Cover
5494	Lever Cover

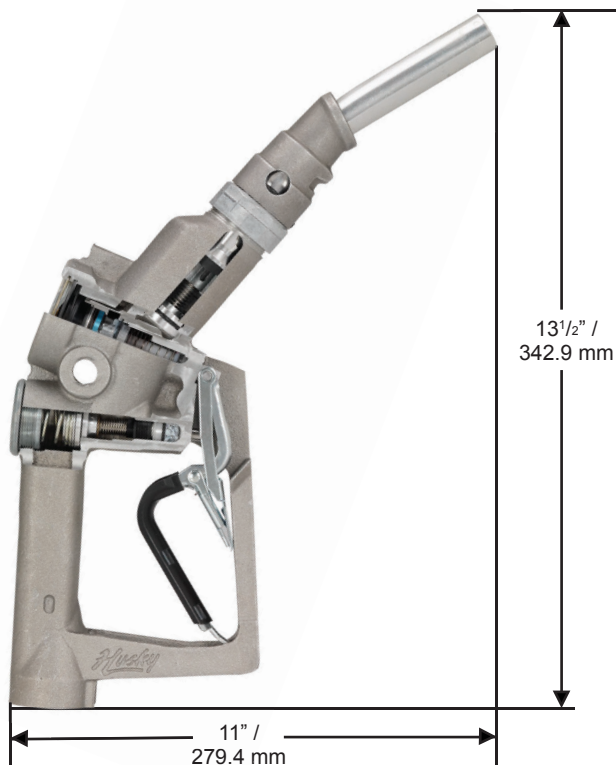
MADE IN THE U.S.A. 

V34iA DP Nozzles



Automatic shut-off vacuum assist nozzle for full-service, self-service and unattended stations.

- V34iA nozzle shuts off when the gas tank is full.
- Strong vapor valve in the nozzle that is mechanically operated by the on-off action of the nozzle's lever.
- Nozzle is equipped with a unique Flo-Stop™ device that shuts off the nozzle if it falls from the fill tank or raises above the horizontal.
- *StreamShaper™* reduces turbulence for straighter flow and less splash back spillage.
- Nozzle is equipped with a double poppet for precise, slow-flow, to-the-penny dispensing.
- Husky vapor return line is an internal part of the body casting, thus eliminating potential vapor leak points and fugitive evaporative emissions from the fuel remaining in the vapor path of the hose.
- Uses conventional spout without spout ring and aluminum vapor escape guard.
- Vapor assist is achieved at the body end of the spout where a vapor ring captures emissions.
- Nozzle spout is covered by a one year warranty.



New Unleaded Nozzles

MODEL NO.	DESCRIPTION	SHIPPING WEIGHT LBS (KG)
7320041	with Double Poppet and Two Notch Hold Open Clip	4.0 (1.8)
7320081	with Double Poppet, without Hold Open Clip	4.0 (1.8)

Construction

Body	Aluminum
Seals	Fluorocarbon
Packing	Double o-ring seal protected by fiber reinforced Teflon
Lever	One piece contoured steel with hard plastic cover
Inlet	M34 x 1.5

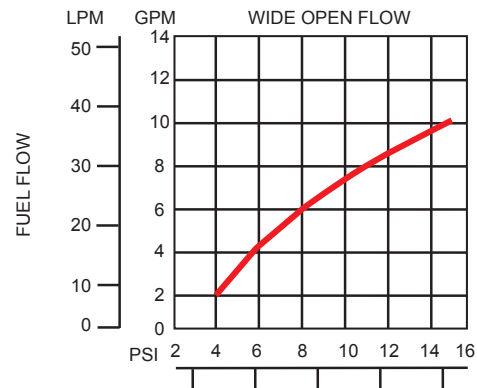
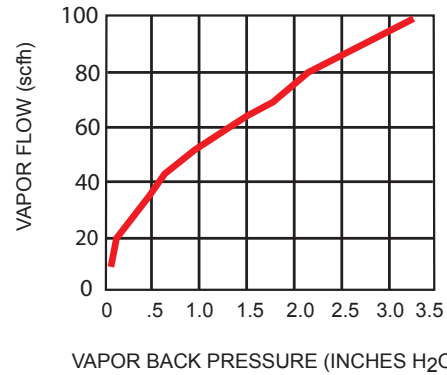

**Husky**

GENERAL FUELING PRODUCTS

V34iA DP Nozzles

Automatic shut-off vacuum assist nozzle for full-service, self-service and unattended stations.

Dimensions and System Options

Safe-T-Breaks®

MODEL NO.	DESCRIPTION
4034	Reconnectable Safe-T-Break®
4034A	Reconnectable Safe-T-Break® - Atex
6210	Non-Reconnectable Safe-T-Break®
5134A	Non-Reconnectable Safe-T-Break® - Atex

Swivels

MODEL NO.	DESCRIPTION
4605	Inverted Vapor Assist Swivel

Pressure/Vacuum Vents

MODEL NO.	DESCRIPTION
4620	2" Slip-On Pressure Vacuum Vent
4885	2" Thread-On Pressure Vacuum Vent - NPTF
5885	2" Thread-On Pressure Vacuum Vent with internal screen - NPTF

Accessories, Testing and Maintenance

MODEL NO.	DESCRIPTION
7089	Nozzle Service Kit
3593	Hold Open Clip Kit
5233	O-ring Replacement Kit
0397	Unleaded Spout Gauge
5837	Vapor Assist Flo-Equalizer™

Guards

MODEL NO.	DESCRIPTION
6951	Full Grip Guard
6660	POPD™ S Full Grip Guard
8184	POPD™ H Full Grip Guard
4231	Full Grip Reguard
7220	POPD™ S Full Grip Reguard
8191	POPD™ H Full Grip Reguard
6628	POPD™ S Clear Cover
7999	POPD™ H Clear Cover
5494	Lever Cover

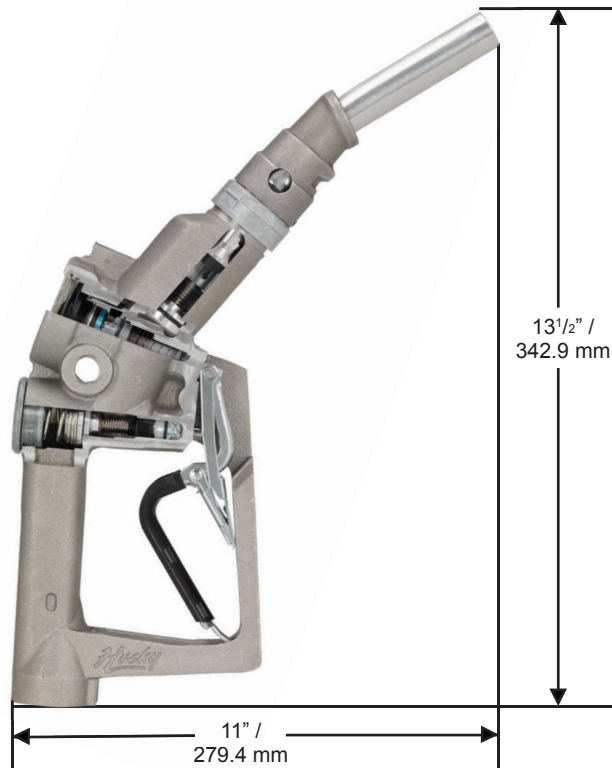
MADE IN THE U.S.A. 

V34iS Nozzles



Pressure activated, automatic shut-off vacuum assist nozzle for full-service, self-service and unattended stations.

- V34iS Nozzle shuts off when
 - the pump shuts off.
 - the gas tank is full.
 - the lever is opened before the pump is turned on.
 - the leak detector has not completed the test cycle.
- Strong vapor valve in the nozzle that is mechanically operated by the on-off action of the nozzle's lever.
- Nozzle is equipped with a unique Flo-Stop™ device that shuts off the nozzle if it falls from the fill tank or raises above the horizontal.
- StreamShaper™ reduces turbulence for straighter flow and less splash back spillage.
- Uses conventional spout with spout ring and soft vapor escape guard.
- Husky vapor return line is an internal part of the body casting, thus eliminating potential vapor leak points and fugitive evaporative emissions from the fuel remaining in the vapor path of the hose.
- Vapor assist achieved at the body end of the spout where a vapor ring catches emissions.
- Nozzle spout is covered by a one year warranty.



New Unleaded Nozzles

MODEL NO.	DESCRIPTION	SHIPPING WEIGHT LBS (KG)
6675041	with Two Notch Hold Open Clip	4.0 (1.8)
6675041A	with Two Notch Hold Open Clip - Atex	4.0 (1.8)

Construction

Body	Aluminum
Seals	Fluorocarbon
Packing	Double o-ring seal protected by fiber reinforced Teflon
Lever	One piece contoured steel with hard plastic cover
Inlet	M34 x 1.5

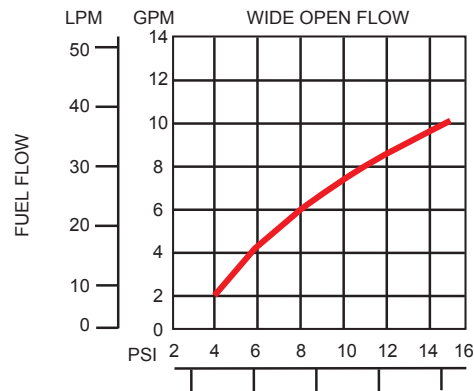
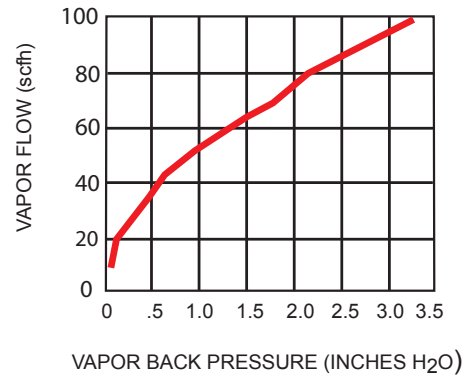

Pending

**Husky**

GENERAL FUELING PRODUCTS

V34iS Nozzles

Pressure activated, automatic shut-off vacuum assist nozzle for full-service, self-service and unattended stations.

Dimensions and System Options

Safe-T-Breaks®

MODEL NO.	DESCRIPTION
4034	Reconnectable Safe-T-Break®
4034A	Reconnectable Safe-T-Break® - Atex
6210	Non-Reconnectable Safe-T-Break®
5134A	Non-Reconnectable Safe-T-Break® - Atex

Swivels

MODEL NO.	DESCRIPTION
4605	Inverted Vapor Assist Swivel

Pressure/Vacuum Vents

MODEL NO.	DESCRIPTION
4620	2" Slip-On Pressure Vacuum Vent
4885	2" Thread-On Pressure Vacuum Vent - NPTF
5885	2" Thread-On Pressure Vacuum Vent with internal screen - NPTF

Accessories, Testing and Maintenance

MODEL NO.	DESCRIPTION
7089	Nozzle Service Kit
3593	Hold Open Clip Kit
0397	Unleaded Spout Gauge
5233	O-ring Kit
5837	Vapor Assist Flo-Equalizer™

Guards

MODEL NO.	DESCRIPTION
6951	Full Grip Guard
6660	POPD™ S Full Grip Guard
8184	POPD™ H Full Grip Guard
4231	Full Grip Reguard
7220	POPD™ S Full Grip Reguard
8191	POPD™ H Full Grip Reguard
6628	POPD™ S Clear Cover
7999	POPD™ H Clear Cover
5494	Lever Guard

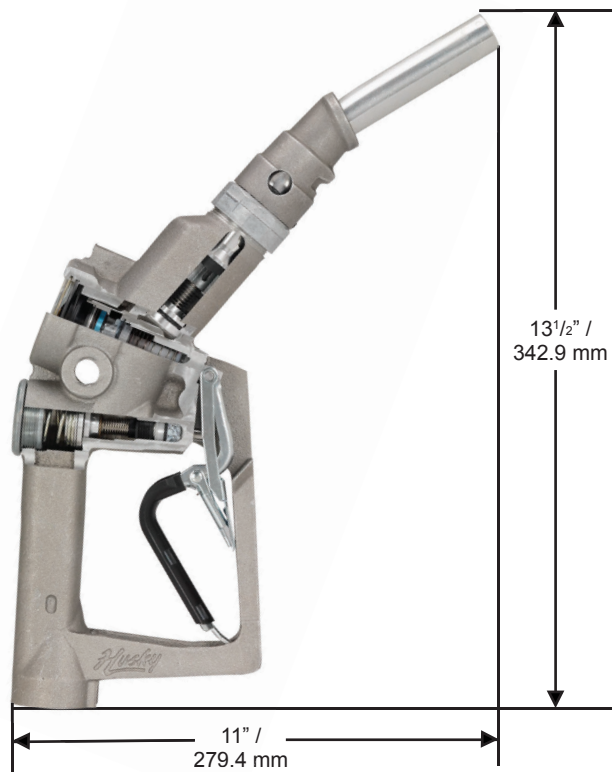

MADE IN THE U.S.A.

V34iS DP Nozzles



Pressure activated, automatic shut-off vacuum assist nozzle for full-service, self-service and unattended stations.

- V34iS Nozzle shuts off when
 - the pump shuts off.
 - the gas tank is full.
 - the lever is opened before the pump is turned on.
 - the leak detector has not completed the test cycle.
- Strong vapor valve in the nozzle that is mechanically operated by the on-off action of the nozzle's lever.
- Nozzle is equipped with a unique Flo-Stop™ device that shuts off the nozzle if it falls from the fill tank or raises above the horizontal.
- StreamShaper™ reduces turbulence for straighter flow and less splash back spillage.
- Nozzle is equipped with a double poppet for precise, slow-flow, to-the-penny dispensing.
- Husky vapor return line is an internal part of the body casting, thus eliminating potential vapor leak points and fugitive evaporative emissions from the fuel remaining in the vapor path of the hose.
- Uses conventional spout without spout ring and aluminum vapor escape guard.
- Vapor assist is achieved at the body end of the spout where a vapor ring captures emissions.



New Unleaded Nozzles

MODEL NO.	DESCRIPTION	SHIPPING WEIGHT LBS (KG)
7345041	with Double Poppet and Two Notch Hold Open Clip	4.0 (1.8)
7345041A*	with High Flow Double Poppet and Two Notch Hold Open Clip - Atex	4.0 (1.8)

Construction

Body	Aluminum
Seals	Fluorocarbon
Packing	Double o-ring seal protected by fiber reinforced Teflon
Lever	One piece contoured steel with hard plastic cover
Inlet	M34 x 1.5

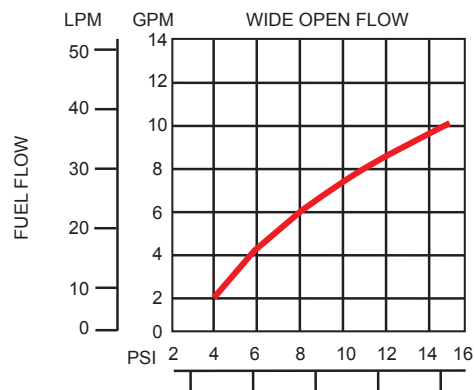
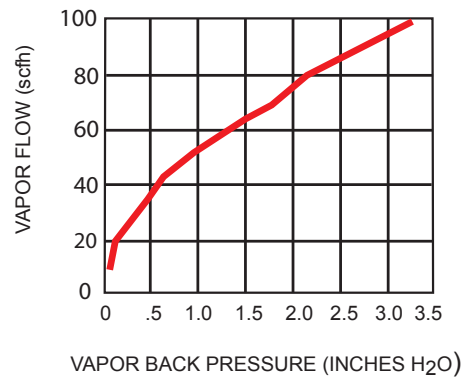

**Husky**

GENERAL FUELING PRODUCTS

V34iS DP Nozzles

Pressure activated, automatic shut-off vacuum assist nozzle for full-service, self-service and unattended stations.

Dimensions and System Options

Safe-T-Breaks®

MODEL NO.	DESCRIPTION
4034	Reconnectable Safe-T-Break®
4034A	Reconnectable Safe-T-Break® - Atex
6210	Non-Reconnectable Safe-T-Break®
5134A	Non-Reconnectable Safe-T-Break® - Atex

Swivels

MODEL NO.	DESCRIPTION
4605	Inverted Vapor Assist Swivel

Pressure/Vacuum Vents

MODEL NO.	DESCRIPTION
4620	2" Slip-On Pressure Vacuum Vent
4885	2" Thread-On Pressure Vacuum Vent - NPTF
5885	2" Thread-On Pressure Vacuum Vent with internal screen - NPTF

Accessories, Testing and Maintenance

MODEL NO.	DESCRIPTION
7089	Nozzle Service Kit
3593	Hold Open Clip Kit
5233	O-ring Replacement Kit
0397	Unleaded Spout Gauge
5837	Vapor Assist Flo-Equalizer™

Guards

MODEL NO.	DESCRIPTION
6951	Full Grip Guard
6660	POPD™ S Full Grip Guard
8184	POPD™ H Full Grip Guard
4231	Full Grip Reguard
7220	POPD™ S Full Grip Reguard
8191	POPD™ H Full Grip Reguard
6628	POPD™ S Clear Cover
7999	POPD™ H Clear Cover
5494	Lever Cover

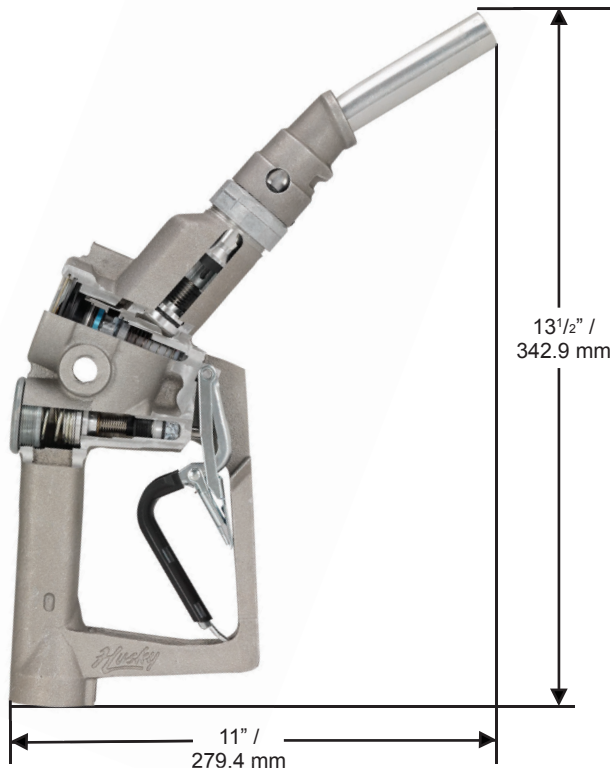

MADE IN THE U.S.A.

V34iSA DP Nozzles



Pressure activated, automatic shut-off vacuum assist nozzle for full-service, self-service and unattended stations.

- V34iS Nozzle shuts off when
 - the pump shuts off.
 - the gas tank is full.
 - the lever is opened before the pump is turned on.
 - the leak detector has not completed the test cycle.
- Strong vapor valve in the nozzle that is mechanically operated by the on-off action of the nozzle's lever.
- Nozzle is equipped with a unique Flo-Stop™ device that shuts off the nozzle if it falls from the fill tank or raises above the horizontal.
- StreamShaper™ reduces turbulence for straighter flow and less splash back spillage.
- Nozzle is equipped with a double poppet for precise, slow-flow, to-the-penny dispensing.
- Husky vapor return line is an internal part of the body casting, thus eliminating potential vapor leak points and fugitive evaporative emissions from the fuel remaining in the vapor path of the hose.
- Uses conventional spout without spout ring and aluminum vapor escape guard.
- Vapor assist is achieved at the body end of the spout where a vapor ring captures emissions.



New Unleaded Nozzles

MODEL NO.	DESCRIPTION	SHIPPING WEIGHT LBS (KG)
7345041	with Double Poppet and Two Notch Hold Open Clip	4.0 (1.8)
7345041A*	with High Flow Double Poppet and Two Notch Hold Open Clip - Atex	4.0 (1.8)

Construction

Body	Aluminum
Seals	Fluorocarbon
Packing	Fiber reinforced Teflon
Lever	One piece contoured steel with hard plastic cover
Inlet	M34 x 1.5

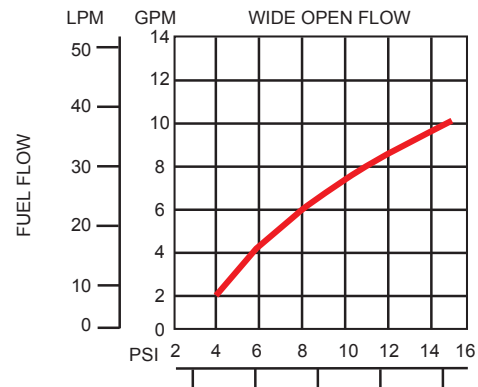
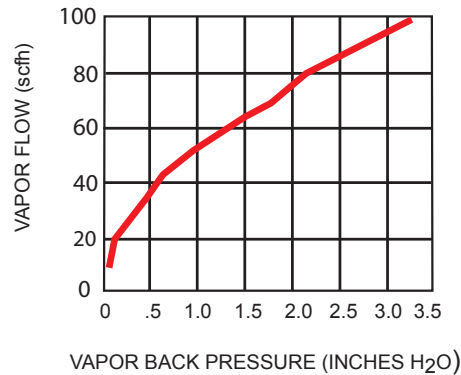

**Husky**

GENERAL FUELING PRODUCTS

V34iSA DP Nozzles

Pressure activated, automatic shut-off vacuum assist nozzle for full-service, self-service and unattended stations.

Dimensions and System Options

Safe-T-Breaks®

MODEL NO.	DESCRIPTION
4034	Reconnectable Safe-T-Break®
4034A	Reconnectable Safe-T-Break® - Atex
6210	Non-Reconnectable Safe-T-Break®
5134A	Non-Reconnectable Safe-T-Break® - Atex

Swivels

MODEL NO.	DESCRIPTION
4605	Inverted Vapor Assist Swivel

Pressure/Vacuum Vents

MODEL NO.	DESCRIPTION
4620	2" Slip-On Pressure Vacuum Vent
4885	2" Thread-On Pressure Vacuum Vent - NPTF
5885	2" Thread-On Pressure Vacuum Vent with internal screen - NPTF

Accessories, Testing and Maintenance

MODEL NO.	DESCRIPTION
7089	Nozzle Service Kit
3593	Hold Open Clip Kit
5233	O-ring Replacement Kit
0397	Unleaded Spout Gauge
5837	Vapor Assist Flo-Equalizer™

Guards

MODEL NO.	DESCRIPTION
6951	Full Grip Guard
6660	POPD™ S Full Grip Guard
8184	POPD™ H Full Grip Guard
4231	Full Grip Reguard
7220	POPD™ S Full Grip Reguard
8191	POPD™ H Full Grip Reguard
6628	POPD™ S Clear Cover
7999	POPD™ H Clear Cover
5494	Lever Cover

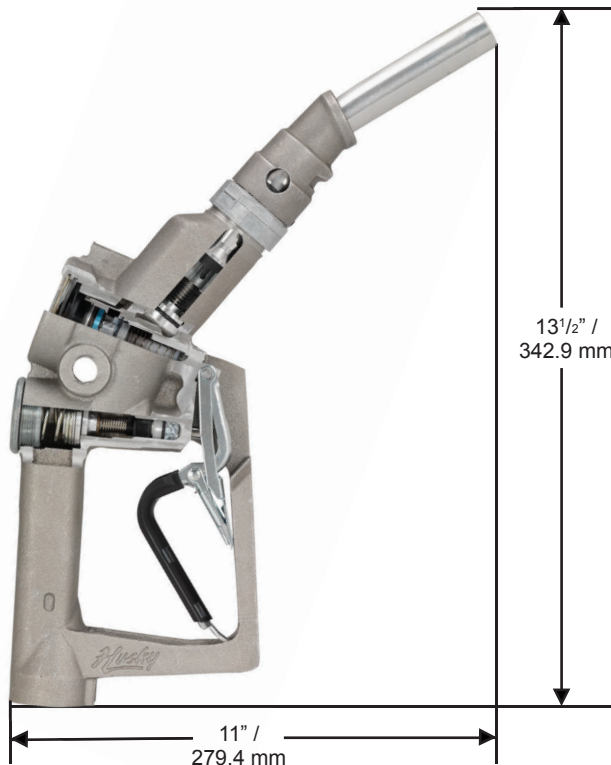

MADE IN THE U.S.A.

VLX Nozzles



Husky VLX is a balance system vapor recovery nozzle capable of delivering 10 GPM.

- The Husky VLX fits existing conventional dispensers. Conversions to Balance Vapor Recovery can be faster, easier and less costly.
- Nozzle is equipped with mechanical interlock that shuts off the nozzle if it falls from the fill tank.
- Nozzle has automatic shut-off so can be used for self-service, full-service, and unattended stations.
- Vapor valve is in the nozzle body, not in the spout.
- Aluminum casting provides a lightweight, easier to handle nozzle.
- Easy and inexpensive to maintain due to the one-piece bellow, the uncluttered spout, and the simple, single bellow clamp.
- The bellow is more flexible and provides greater resistance to cuts, scuffing and damage. It has the lightest "force" needed to insert/seal of any bellows nozzle.
- *StreamShaper™* reduces turbulence for a straighter fuel flow and less splash back spillage.



Short Spout Nozzles

MODEL NO.	DESCRIPTION	SHIPPING WEIGHT LBS (KG)
5010	New with Three Notch Hold Open Clip	3.9 (1.7)
5020	New without Hold Open Clip	3.9 (1.7)
5010100	New with Three Notch Hold Open Clip, POPD™ Full Grip Guard and Sightglass	4.2 (1.9)
5410	Rebuilt with Three Notch Hold Open Clip	4.2 (1.9)
5420	Rebuilt without Hold Open Clip	4.2 (1.9)

Long Spout Nozzles

MODEL NO.	DESCRIPTION	SHIPPING WEIGHT LBS (KG)
5210	New with Three Notch Hold Open Clip	4.0 (1.8)
5220	New without Hold Open Clip	4.0 (1.8)
5450	Rebuilt with Three Notch Hold Open Clip	4.0 (1.8)
5460	Rebuilt without Hold Open Clip	4.0 (1.8)

Construction

Body	Aluminum
Seals	Fluorocarbon
Packing	Fiber Reinforced Teflon
Lever	One piece contoured steel with hard plastic cover
Inlet	1 1/8" x 12

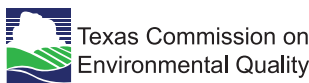
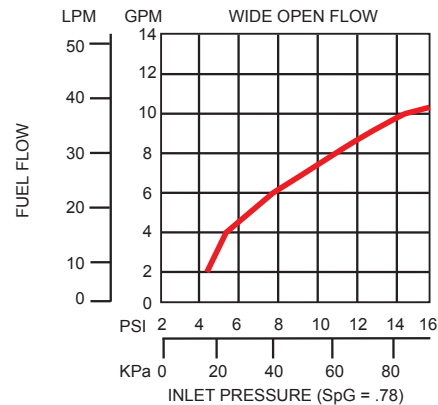

Husky VLX is a balance system vapor recovery nozzle capable of delivering 10 GPM.

Dimensions and System Options

Safe-T-Breaks®

MODEL NO.	DESCRIPTION
3360VR	Reconnectable Safe-T-Break®
5900	Non-Reconnectable Safe-T-Break®

Spouts

MODEL NO.	DESCRIPTION
6320	Complete Unleaded Assembly Kit - Short
6440	Unleaded Spout - Short
6322	Complete Unleaded Assembly Kit - Long
6445	Unleaded Spout - Long

Pressure/Vacuum Vents

MODEL NO.	DESCRIPTION
4620	2" Slip-On Pressure Vacuum Vent
4885	2" Thread-On Pressure Vacuum Vent - NPTF
5885	2" Thread-On Pressure Vacuum Vent with internal screen - NPT

Accessories, Testing and Maintenance

MODEL NO.	DESCRIPTION
7089	Nozzle Service Kit
3593	Hold Open Clip Kit
3364	Bellow Clamp Tool
0397	Unleaded Spout Gauge
5827	Balance Vapor Recovery Flo-Equalizer™
5801	Short Bellow Assembly with Clamp
5803	Short Bellow Spring Assembly
5901	Long Bellow Assembly with Clamp
5903	Long Bellow Spring Assembly
2879	Bellow Clamp
6188	Goodyear® Premier LX 8' Hose with Left Hand Threads

Guards

MODEL NO.	DESCRIPTION
5950	Full Grip Guard
6650	POPD™ S Full Grip Guard
8182	POPD™ H Full Grip Guard
4190	Full Grip Reguard
7215	POPD™ S Full Grip Reguard
8189	POPD™ H Full Grip Reguard
6628	POPD™ S Clear Cover
7999	POPD™ H Clear Cover
5494	Lever Cover

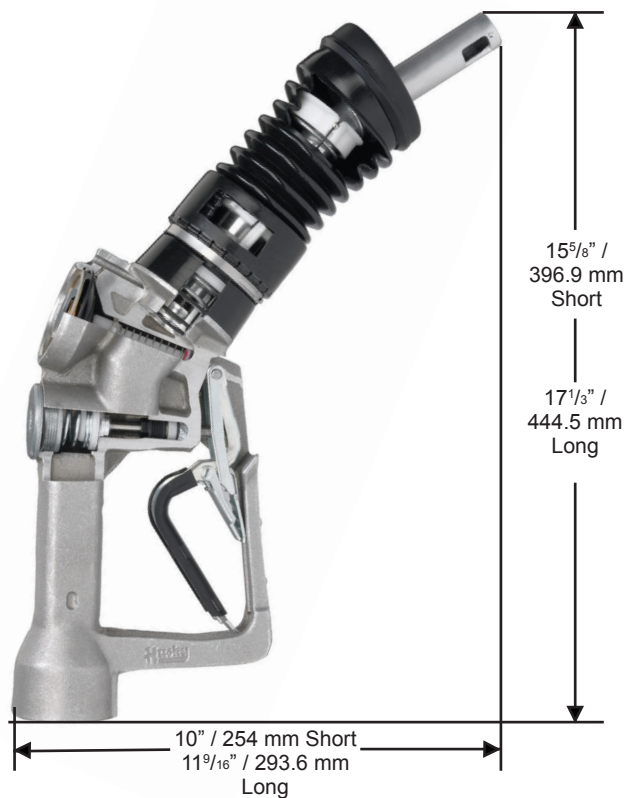



Husky

GENERAL FUELING PRODUCTS

Ethanol Fueling Nozzles

X E85 Nozzles



Automatic shut-off nozzle for full-service and self-service stations.

- Aluminum body, spout, and internal parts are nickel plated to prevent contamination and corrosion from Ethanol blends.
- *StreamShaper™* reduces turbulence for straighter fuel flow and less splash back spillage.
- Compatible with unleaded and all Ethanol blends through E-85.
- Aluminum reinforced spout bushing keeps the spout tip round and acts as a captive fastener to prevent tip-end sensor damage.
- Nozzle is equipped with a unique Flo-Stop™ device that shuts off the nozzle if it falls from the fill tank or raises above the horizontal.
- Husky X nozzle shut off when the gas tank is full.
- Nozzle comes with smooth Full Grip Guard



New Unleaded Nozzles

MODEL NO.	DESCRIPTION	SHIPPING WEIGHT LBS (KG)
659404	with Three Notch Hold Open Clip	2.8 (1.2)
659459	with Three Notch Hold Open Clip and Waffle Splash Guard	3.0 (1.2)
659444	with Three Notch Hold Open Clip, Waffle Splash Guard and Flo-Equalizer™	3.0 (1.2)
659454	with Three Notch Hold Open Clip and Flo-Equalizer™	2.8 (1.2)
6594100	with Three Notch Hold Open Clip, POPD™ Full Grip Guard, Waffle Splash Guard and Sightglass	3.0 (1.2)

Construction

Body	One piece die cast aluminum with Electroless Nickel Plating
Seals	Fluorocarbon
Packing	Double O-ring seal protected by fiber reinforced Teflon
Lever	One piece contoured steel with hard plastic cover.
Inlet	¾" / 19 mm NPTF

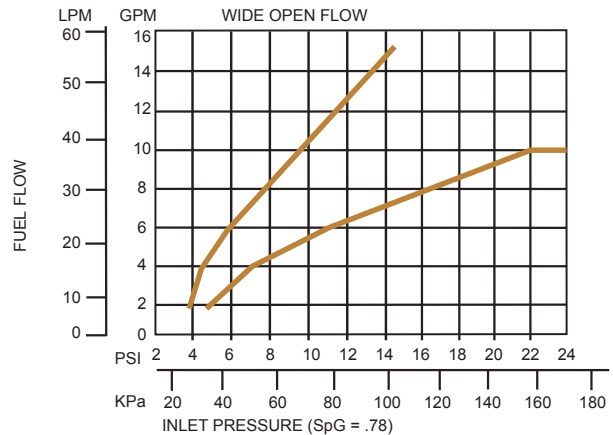

**Husky**

GENERAL FUELING PRODUCTS

X E85 Nozzles

Automatic shut-off nozzle for full-service and self-service stations.

Dimensions and System Options

Safe-T-Breaks®

MODEL NO.	DESCRIPTION
6360	¾" F x ¾" F Reconnectable E85 Safe-T-Break®
6273	¾" F x ¾" F Non-Reconnectable E85 Safe-T-Break®

Swivels

MODEL NO.	DESCRIPTION
6350	¾" M x ¾" F Multi-plane E85 Swivel

Spouts

MODEL NO.	DESCRIPTION
6207	Unleaded E85 Spout w/o Flo-Stop™

Pressure/Vacuum Vents

MODEL NO.	DESCRIPTION
4620	2" Slip-On Pressure Vacuum Vent
4885	2" Thread-On Pressure Vacuum Vent - NPTF
5885	2" Thread-On Pressure Vacuum Vent with internal screen - NPTF

Accessories, Testing and Maintenance

MODEL NO.	DESCRIPTION
7089	Nozzle Service Kit
3593	Hold Open Clip Kit
0397	Unleaded Spout Gauge
7490	Internal Flo-Equalizer™ - 10 gpm / 37.9 Lpm

Guards

MODEL NO.	DESCRIPTION
4145	Full Grip Guard
6665	POPD™ Full Grip Guard
1806	Full Grip Reguard
7205	POPD™ Full Grip Reguard
3795	Mate Guard
7815	POPD™ Mate Guard
1808	Waffle Splash Guard
1506	Protection Package
1809	Reguard Protection Package
3440	Mate Easy-on Package
6628	POPD™ Clear Cover
5494	Lever Guard
3376	Black Handle Guard

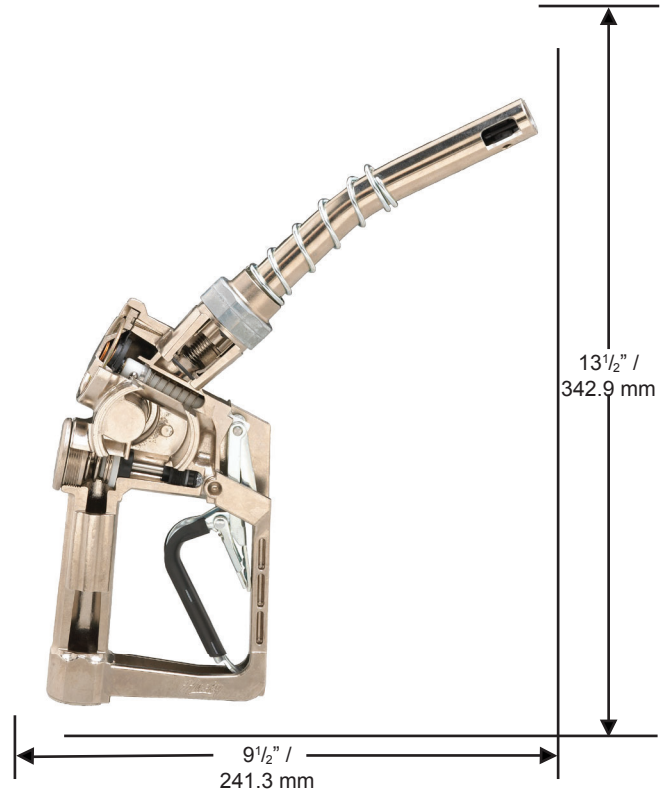

MADE IN THE U.S.A. 

X E85 CW Nozzles



Husky

GENERAL FUELING PRODUCTS

Automatic shut-off nozzle for full-service and self-service stations.

- Aluminum body, spout, and internal parts are nickel plated to prevent contamination and corrosion from Ethanol blends.
- Contains a poppet disc seal rated at -40° F/C to prevent fuel leakage from the main seal in extreme cold weather.
- *StreamShaper™* reduces turbulence for straighter fuel flow and less splash back spillage.
- Compatible with unleaded and all Ethanol blends through E-85.
- Aluminum reinforced spout bushing keeps the spout tip round and acts as a captive fastener to prevent tip-end sensor damage.
- Nozzle is equipped with a unique Flo-Stop™ device that shuts off the nozzle if it falls from the fill tank or raises above the horizontal.
- Nozzle comes with smooth Full Grip Guard

New Unleaded Nozzles

MODEL NO.	DESCRIPTION	SHIPPING WEIGHT LBS (KG)
665904	with Three Notch Hold Open Clip	2.5 (1.3)
665964	with Three Notch Hold Open Clip and Waffle Splash Guard	2.5 (1.3)
665954	with Three Notch Hold Open Clip and Flo-Equalizer™	2.5 (1.3)
665944	with Three Notch Hold Open Clip, Waffle Splash Guard and Flo-Equalizer™	2.5 (1.3)

Construction

Body	One piece die cast aluminum
Seals	Fluorocarbon
Packing	Double O-ring seal protected by fiber reinforced Teflon
Lever	One piece contoured steel
Inlet	¾" / 19 mm NPTF

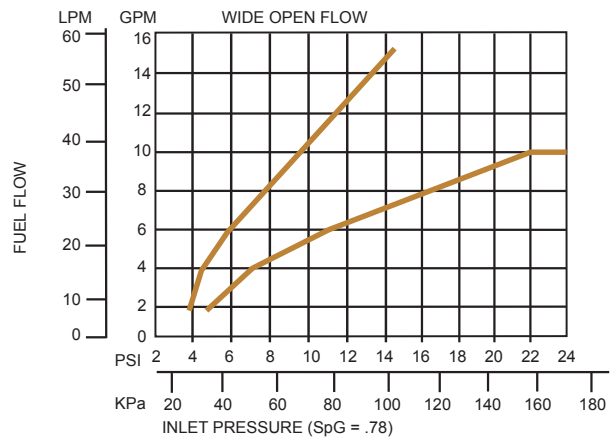

**Husky**

GENERAL FUELING PRODUCTS

X E85 CW Nozzles

Automatic shut-off nozzle for full-service and self-service stations.

Dimensions and System Options

Safe-T-Breaks®

MODEL NO.	DESCRIPTION
6360	¾" F x ¾" F Reconnectable E85 Safe-T-Break®
6273	¾" F x ¾" F Non-Reconnectable E85 Safe-T-Break®

Swivels

MODEL NO.	DESCRIPTION
6350	¾" M x ¾" F Multi-plane E85 Swivel

Spouts

MODEL NO.	DESCRIPTION
6207	X, XS E85 Spout Assy w/ <i>Streamshaper™</i>

Pressure/Vacuum Vents

MODEL NO.	DESCRIPTION
4620	2" Slip-On Pressure Vacuum Vent
4885	2" Thread-On Pressure Vacuum Vent - NPTF
5885	2" Thread-On Pressure Vacuum Vent with internal screen - NPTF

Accessories, Testing and Maintenance

MODEL NO.	DESCRIPTION
7089	Nozzle Service Kit
3593	Hold Open Clip Kit
0397	Unleaded Spout Gauge
7490	Internal Flo-Equalizer™ - 10 gpm / 37.9 Lpm

Guards

MODEL NO.	DESCRIPTION
4145	Full Grip Guard
6665	POPD™ Full Grip Guard
1806	Full Grip Reguard
7205	POPD™ Full Grip Reguard
3795	Mate Guard
7815	POPD™ Mate Guard
1808	Waffle Splash Guard
1506	Protection Package
1809	Reguard Protection Package
3440	Mate Easy-on Package
6628	POPD™ Clear Cover
5494	Lever Guard
3376	Black Handle Guard

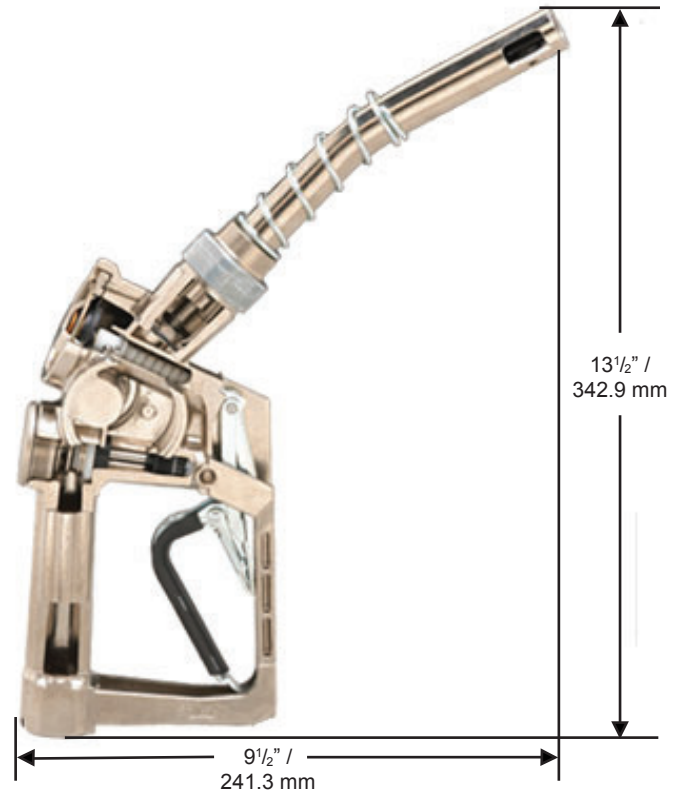

MADE IN THE U.S.A.



XS E85 Nozzles



Pressure activated, automatic shut off nozzle for full-service, self-service and unattended stations.

- XS® E85 Nozzle shuts off when
 - the pump shuts off.
 - the gas tank is full.
 - the lever is opened before the pump is turned on.
 - the leak detector has not completed the test cycle.
- Aluminum body, spout, and internal parts are nickel plated to prevent contamination and corrosion from Ethanol blends.
- StreamShaper™ reduces turbulence for straighter fuel flow and less splash back spillage.
- Compatible with unleaded and all Ethanol blends through E-85.
- Aluminum reinforced spout bushing keeps the spout tip round and acts as a captive fastener to prevent tip-end sensor damage.
- Nozzle is equipped with a unique Flo-Stop™ device that shuts off the nozzle if it falls from the fill tank or raises above the horizontal.
- Nozzle comes with smooth Full Grip Guard

New Unleaded Nozzles

MODEL NO.	DESCRIPTION	SHIPPING WEIGHT LBS (KG)
659504	with Three Notch Hold Open Clip	3.0 (1.3)
659559	with Three Notch Hold Open Clip and Waffle Splash Guard	2.9 (1.3)
659544	with Three Notch Hold Open Clip, Waffle Splash Guard & Flo-Equalizer™	3.0 (1.3)
659554	with Three Notch Hold Open Clip and Flo-Equalizer™	2.9 (1.3)
659589	with Three Notch Hold Open Clip, POPD™ Full Grip Guard and Waffle Splash Guard	3.0 (1.3)
6595100	with Three Notch Hold Open Clip, POPD™ Full Grip Guard, Waffle Splash Guard and Sightglass	3.0 (1.3)

Construction

Body	One piece die cast aluminum with Electroless Nickel Plating
Seals	Fluorocarbon
Packing	Double O-ring seal protected by fiber reinforced Teflon
Lever	One piece contoured steel with hard plastic cover.
Inlet	¾" / 19 mm NPTF

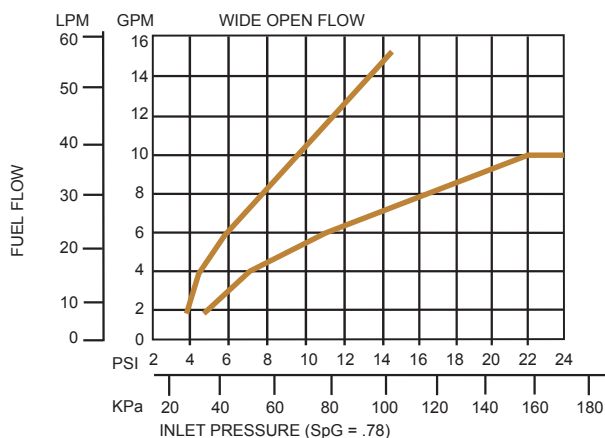

**Husky**

GENERAL FUELING PRODUCTS

XS E85 Nozzles

Pressure activated, automatic shut off nozzle for full-service, self-service and unattended stations.

Dimensions and System Options

Safe-T-Breaks®

MODEL NO.	DESCRIPTION
6360	¾" F x ¾" F Reconnectable E85 Safe-T-Break®
6273	¾" F x ¾" F Non-Reconnectable E85 Safe-T-Break®

Swivels

MODEL NO.	DESCRIPTION
6350	¾" M x ¾" F Multi-plane E85 Swivel

Spouts

MODEL NO.	DESCRIPTION
6207	Unleaded E85 Spout w/o Flo-Stop™

Pressure/Vacuum Vents

MODEL NO.	DESCRIPTION
4620	2" Slip-On Pressure Vacuum Vent
4885	2" Thread-On Pressure Vacuum Vent - NPTF
5885	2" Thread-On Pressure Vacuum Vent with internal screen - NPTF

Accessories, Testing and Maintenance

MODEL NO.	DESCRIPTION
7089	Nozzle Service Kit
3593	Hold Open Clip Kit
0397	Unleaded Spout Gauge
7490	Internal Flo-Equalizer™ - 10 gpm / 37.9 Lpm

Guards

MODEL NO.	DESCRIPTION
4145	Full Grip Guard
6665	POPD™ Full Grip Guard
1806	Full Grip Reguard
7205	POPD™ Full Grip Reguard
3795	Mate Guard
7815	POPD™ Mate Guard
1808	Waffle Splash Guard
1506	Protection Package
1809	Reguard Protection Package
3440	Mate Easy-on Package
6628	POPD™ Clear Cover
5494	Lever Guard
3376	Black Handle Guard



MADE IN THE U.S.A.



XS E85 CW Nozzles



Husky

GENERAL FUELING PRODUCTS

Pressure activated, automatic shut-off nozzle for full-service, self-service and unattended stations.

- XS® E85 Nozzle shuts off when
 - the pump shuts off.
 - the gas tank is full.
 - the lever is opened before the pump is turned on.
 - the leak detector has not completed the test cycle.
- Aluminum body, spout, and internal parts are nickel plated to prevent contamination and corrosion from Ethanol blends.
- Contains a poppet disc seal rated at -40° F/C to prevent fuel leakage from the main seal in extreme cold weather.
- *StreamShaper™* reduces turbulence for straighter fuel flow and less splash back spillage.
- Compatible with unleaded and all Ethanol blends through E-85.
- Aluminum reinforced spout bushing keeps the spout tip round and acts as a captive fastener to prevent tip-end sensor damage.
- Nozzle is equipped with a unique Flo-Stop™ device that shuts off the nozzle if it falls from the fill tank or raises above the horizontal.
- Nozzle comes with smooth Full Grip Guard.



New Unleaded Nozzles

MODEL NO.	DESCRIPTION	SHIPPING WEIGHT LBS (KG)
666104	with Three Notch Hold Open Clip	2.6 (1.1)
666164	with Three Notch Hold Open Clip and Waffle Splash Guard	2.9 (1.3)
666154	with Three Notch Hold Open Clip and Flo-Equalizer™	2.6 (1.1)
666144	with Three Notch Hold Open Clip, Waffle Splash Guard and Flo-Equalizer™	2.9 (1.3)

Construction

Body	One piece die cast aluminum
Seals	Fluorocarbon
Packing	Double O-ring seal protected by fiber reinforced Teflon
Lever	One piece contoured steel
Inlet	¾" / 19 mm NPTF

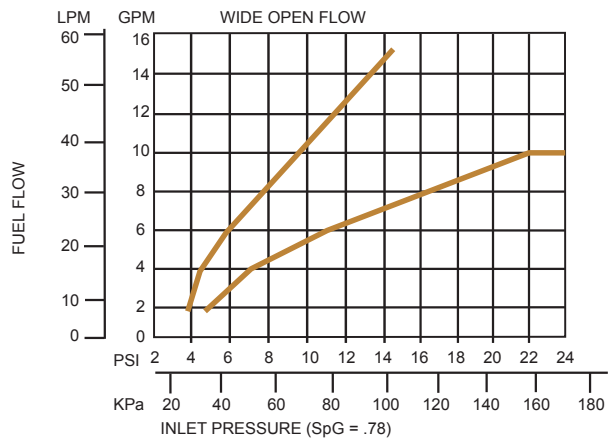

**Husky**

GENERAL FUELING PRODUCTS

XS E85 CW Nozzles

Pressure activated, automatic shut-off nozzle for full-service, self-service and unattended stations.

Dimensions and System Options

Safe-T-Breaks®

MODEL NO.	DESCRIPTION
6360	¾" F x ¾" F Reconnectable E85 Safe-T-Break®
6273	¾" F x ¾" F Non-Reconnectable E85 Safe-T-Break®

Swivels

MODEL NO.	DESCRIPTION
6350	¾" M x ¾" F Multi-plane E85 Swivel

Spouts

MODEL NO.	DESCRIPTION
6207	Unleaded E85 Spout w/o Flo-Stop™

Pressure/Vacuum Vents

MODEL NO.	DESCRIPTION
4620	2" Slip-On Pressure Vacuum Vent
4885	2" Thread-On Pressure Vacuum Vent - NPTF
5885	2" Thread-On Pressure Vacuum Vent with internal screen - NPTF

Accessories, Testing, and Maintenance

MODEL NO.	DESCRIPTION
7089	Nozzle Service Kit
3593	Hold Open Clip Kit
0397	Unleaded Spout Gauge
7490	Internal Flo-Equalizer™ - 10 gpm / 37.9 Lpm

Guards

MODEL NO.	DESCRIPTION
4145	Full Grip Guard
6665	POPD™ Full Grip Guard
1806	Full Grip Reguard
7205	POPD™ Full Grip Reguard
3795	Mate Guard
7815	POPD™ Mate Guard
1808	Waffle Splash Guard
1506	Protection Package
1809	Reguard Protection Package
3440	Mate Easy-on Package
6628	POPD™ Clear Cover
5494	Lever Guard
3376	Black Handle Guard

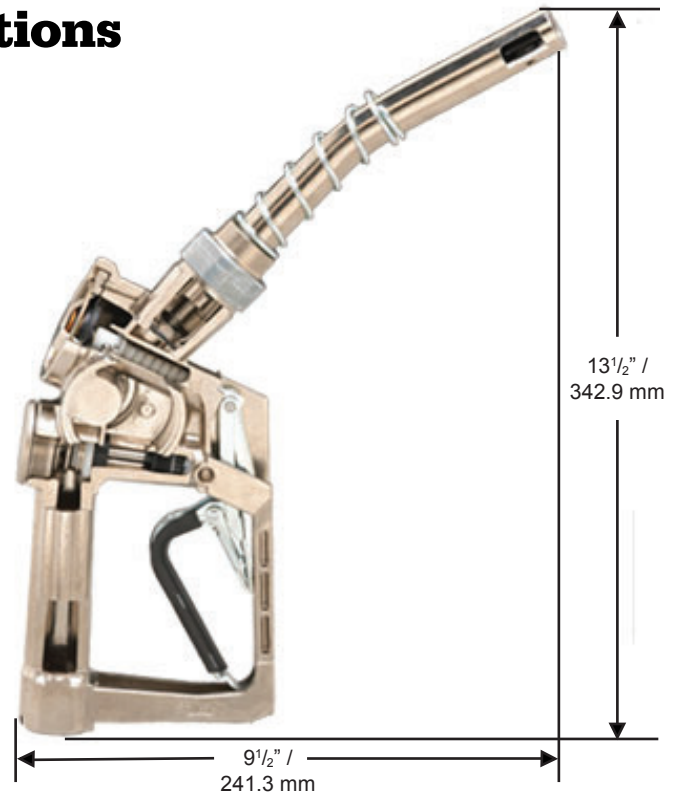

MADE IN THE U.S.A.



Husky

GENERAL FUELING PRODUCTS

CNG Nozzles

CNG Nozzles



NGV1 compatible, 3600 psi (248.2 bar) compressed natural gas dispensing nozzle for quick-fill applications.

- Ergonomic, single-hand design for easy connecting and disconnecting.
- Swivels at inlet fitting.
- Comes standard with yellow scuff guard.
- JawLoc design prevents receptacle wear.
- PressureLoc sleeve prevents disconnection at high pressures.
- Outer sleeve anodized to prevent corrosion.
- Tamper-proof design prevents unauthorized disassembly.
- Light-weight construction compared to similar nozzles.
- Designed for use with shorter pipe nipple / dispensing hose which allows easier access to the fuel pocket and clearance of the 3-way ball valve.
- Easy grip sleeve for better access to fuel pocket.
- Nozzle covered by a one (1) year warranty.

New Nozzles

MODEL NO.	DESCRIPTION	SHIPPING WEIGHT LBS (KG)
8695	Type 2A Compressed Natural Gas Dispensing Nozzle	2 (0.9)

Construction

Body	Aircraft-grade aluminum body with stainless steel locking jaws Chromate conversion coating (Alodine) internal parts
Seals	Fluorocarbon with PTFE backup rings
Inlet	1/16-18 UNF, SAE J1926-1 O-ring port



NGV1 compatible, 3600 psi (248.2 bar) compressed natural gas dispensing nozzle for quick-fill applications.

Dimensions





Husky

GENERAL FUELING PRODUCTS

Whiskey Nozzles

Automatic shut-off nozzle for Wine / Whiskey dispensing.

- Modular design for easy cleaning.
- Comes standard with mate nozzle guard and fluted handle cover.
- Nozzle shuts off when the container is full.
- Stainless Steel construction.



New WN Nozzles

MODEL NO.	DESCRIPTION	SHIPPING WEIGHT LBS (KG)
8528104	Stainless steel, 1" Inlet BSPP Threads 3/4" OD spout, mate nozzle guard and two notch hold open clip	3.0 (1.3)

Construction

Body	Investment Cast Stainless Steel
Disc	Ethylene Propylene
Packing	Double o-ring seal protected by fiber reinforced Teflon
Lever	One piece countoured steel with hard plastic cover
Inlet	1" / 25.4 mm BSPP

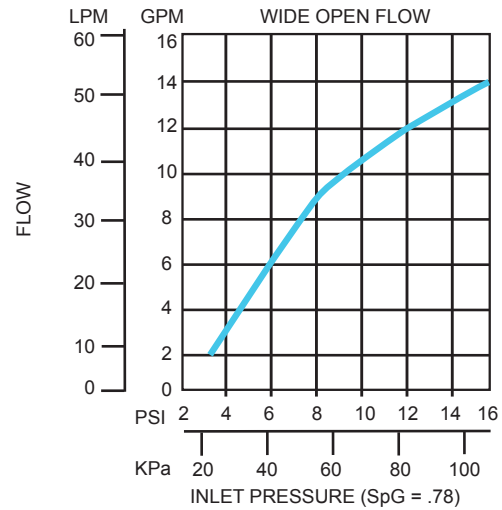

Automatic shut-off nozzle for Wine / Whiskey dispensing.

Dimensions and System Options

Guards

MODEL NO.	DESCRIPTION
0226	Mate Guard
8169	POPD™ S Mate Guard
8170	POPD™ H Mate Guard
8179	POPD™ EZS Nozzle Guard
8180	POPD™ EZH Nozzle Guard
1808	Waffle Splash Guard
6628	POPD™ S Clear Cover
7999	POPD™ H Clear Cover
7376	Handle Cover (Black)

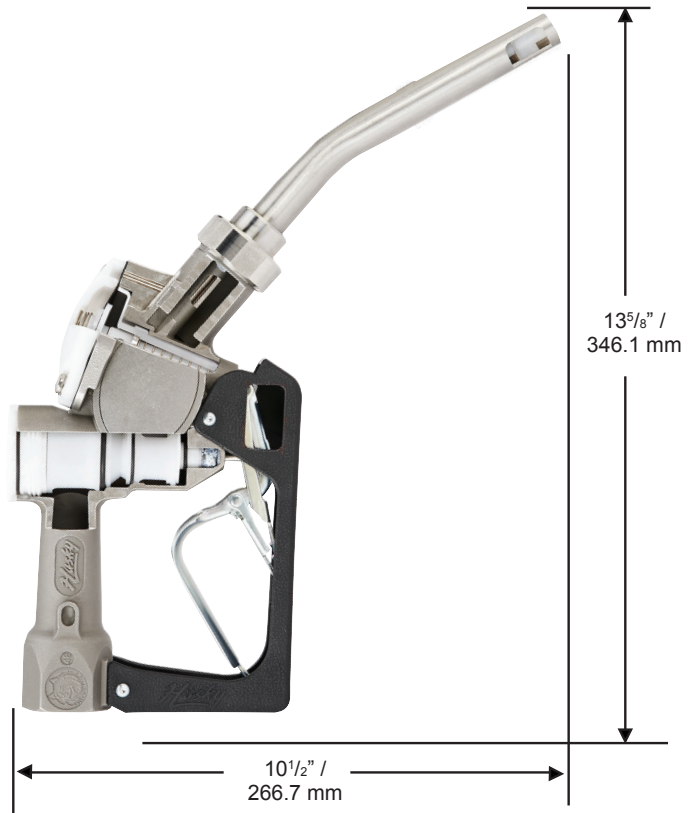

Automatic shut-off nozzle for Wine / Whiskey dispensing.

- Aluminum body, spout, and internal parts are nickel-plated to prevent contamination and corrosion.
- *StreamShaper™* reduces turbulence for straighter flow and less splash back spillage.
- Nozzle comes with Mate Nozzle Guard and Black Handle Guard.
- Stainless steel reinforced spout bushing keeps the spout tip round and acts as a captive fastener to prevent tip-end sensor damage.
- Nozzle shuts off when the container is full.



New XWVN Nozzles

MODEL NO.	DESCRIPTION	SHIPPING WEIGHT LBS (KG)
840004	Nickel-Plated, with 3/4" Inlet NPTF Threads, 13/16" O.D. Spout, Mate Nozzle Guard, and Three Notch Hold Open Clip; without Flo-Stop™	2.8 (1.2)

Construction

Body	One piece die cast aluminum with Electroless Nickel Plating
Disc	Fluorocarbon
Packing	Double O-ring seal protected by fiber reinforced Teflon
Lever	One piece high-impact polymer
Inlet	3/4" / 19 mm NPTF

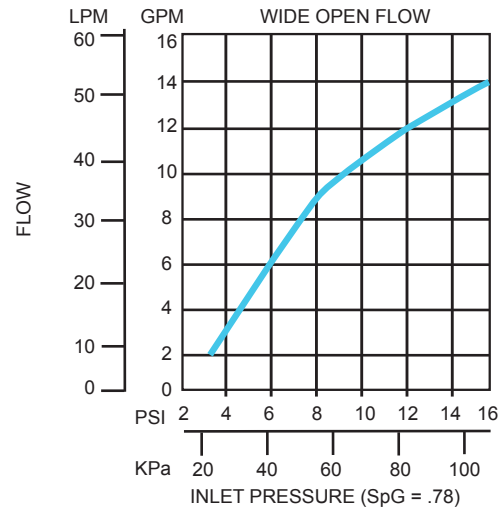

Automatic shut-off nozzle for Wine / Whiskey dispensing.

Dimensions and System Options

Guards

MODEL NO.	DESCRIPTION
3795	Mate Guard
8165	POPD™ S Mate Guard
8166	POPD™ H Mate Guard
8175	POPD™ EZS Nozzle Guard
8176	POPD™ EZH Nozzle Guard
1808	Waffle Splash Guard
3440	Mate Easy-on Package
6628	POPD™ S Clear Cover
7999	POPD™ H Clear Cover
5494	Lever Guard
3376	Black Handle Guard

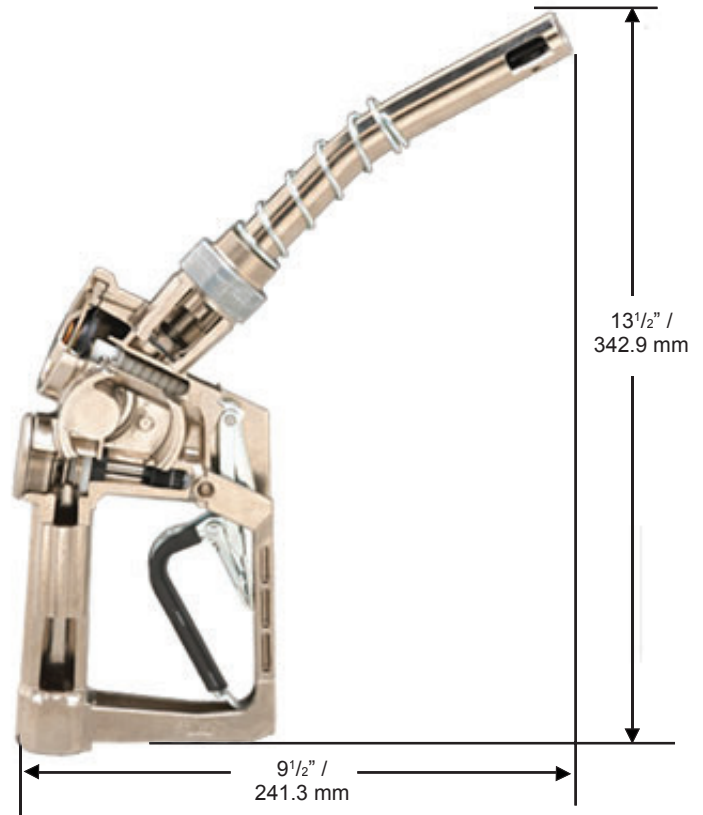



Husky

GENERAL FUELING PRODUCTS

Swivels

Standard Swivels



For standard fueling applications.

All Husky Multi-Plane Swivels

- Compatible with unlead, diesel, and Ethanol blends through E10.
 - Compact and light weight for easy handling.
 - High flow rates due to laminar flow design.
 - High strength step shoulder bearing diameters and impact absorbing stops.
- Model 2950 Restricted Swivel**
- Multi-Plane, 210° spherical rotation at the swivel nut.
 - Double o-ring seals at each swivel provide long life at low temperatures (-40° F/C).

All Weather Swivels

- Multi-Plane, Full 360° spherical rotation for easy movement of nozzle.
- Double o-ring seals at each swivel provide long life at low temperatures (-40° F/C).

Warm Weather Swivels

- Multi-Plane, Full 360° spherical rotation for easy movement of nozzle.
- Double o-ring seals at each swivel provide long life at high temperatures (482° F / 250° C).

All Weather NPTF

MODEL NO.	DESCRIPTION	SHIPPING WEIGHT LBS (KG)
0350	3/4" M x 3/4" F Swivel	.50 (.22)
0352	1" M x 3/4" F Swivel	.66 (.29)
0355	3/4" M x 3/4" F Black Swivel	.49 (.22)
0356	1" M x 3/4" F Black Swivel	.66 (.29)
2272	3/4" M x 3/4" F 90° Swivel	.38 (.17)
2950	3/4" M x 3/4" F Restricted Swivel	.50 (.22)

Warm Weather NPTF

MODEL NO.	DESCRIPTION	SHIPPING WEIGHT LBS (KG)
0350W	3/4" M x 3/4" F Swivel	.50 (.22)
0352W	1" M x 3/4" F Swivel	.66 (.29)
All Weather BSPP		
1491	3/4" M x 3/4" F BSPT Swivel	.50 (.22)
3590	3/4" M x 3/4" F BSPP Swivel	.60 (.27)
3590A	3/4" M X 3/4" F BSPP Swivel with Atex Certification	.60 (.27)
2771	3/4" M x 3/4" F 90° BSPP Swivel	.38 (.17)
2771A*	3/4" M x 3/4" F 90° BSPP Swivel with Atex certification	.38 (.17)

Warm Weather BSPP

MODEL NO.	DESCRIPTION	SHIPPING WEIGHT LBS (KG)
3590W	3/4" M x 3/4" F BSPP Swivel	.60 (.27)

Construction

ALL WEATHER

Body	High Aluminum Zinc Alloy
Inner O-ring	Fluorosilicone
Outer O-ring	Fluorocarbon

WARM WEATHER

Body	High Aluminum Zinc Alloy
Inner O-ring	Fluorocarbon
Outer O-ring	Fluorocarbon



Model 0352



Model 0350



Model 2272

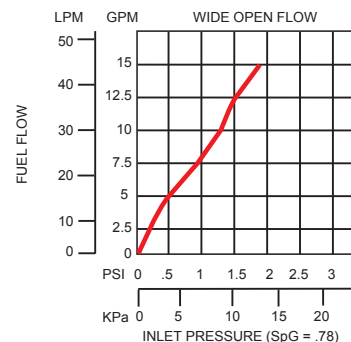
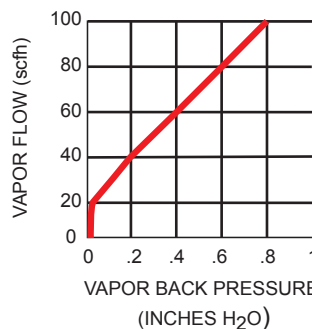



For standard fueling applications.

Dimensions

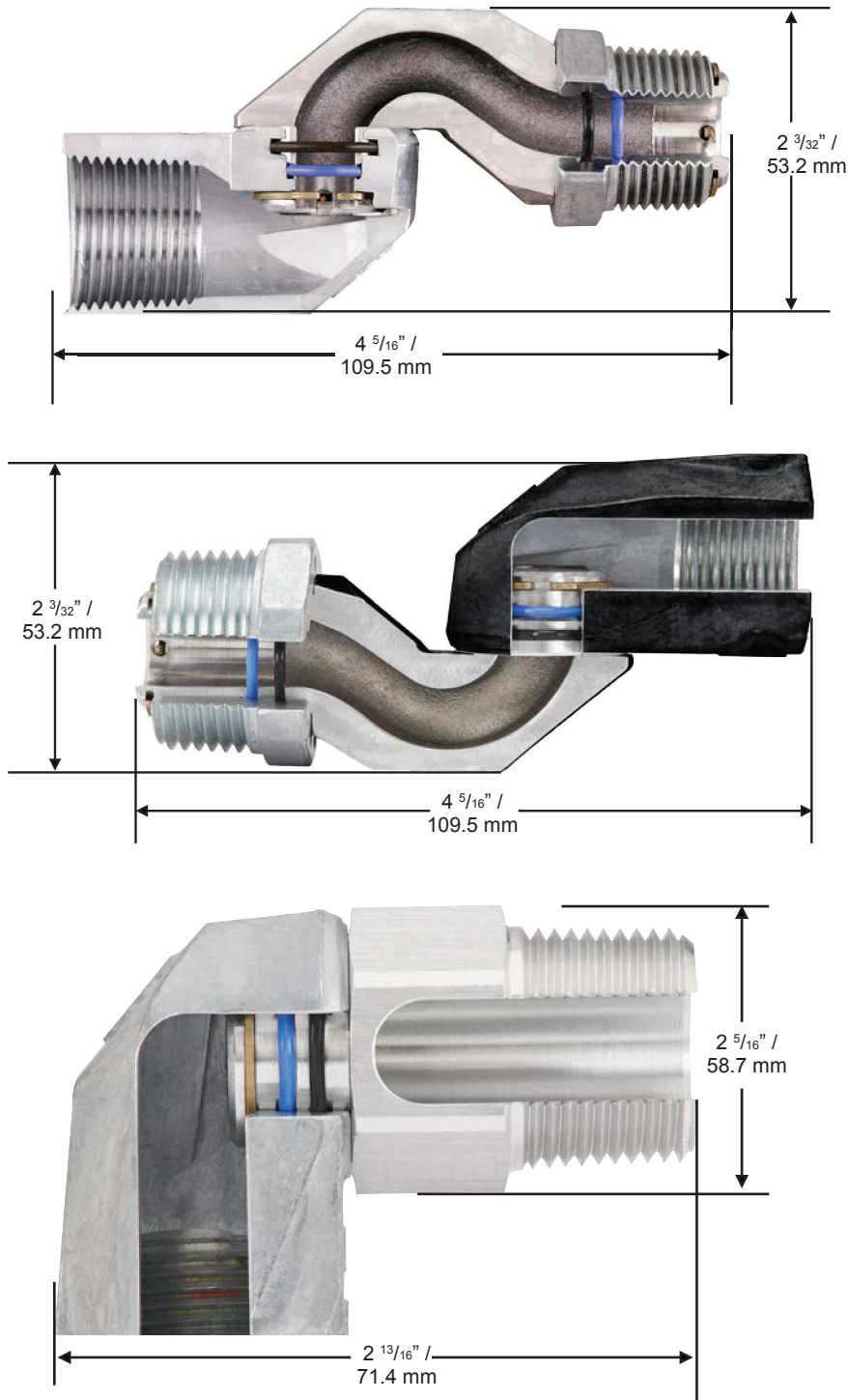

Inline Swivels



For standard fueling applications.

All Multi-Plane Swivels

- Compatible with unlead, diesel, and Ethanol blends through E10.
- Compact and light weight for easy handling.
- High flow rates due to laminar flow design.
- High strength step shoulder bearing diameters and impact absorbing stops.

All Weather Swivels

- Multi-Plane, Full 360° spherical rotation for easy movement of nozzle.
- Double o-ring seals at each swivel provide long life at low temperatures (-40° F/C).



Model 3896

NPTF Threads

MODEL NO.	DESCRIPTION	SHIPPING WEIGHT LBS (KG)
3895	3/4" M x 3/4" F Single Plane Swivel	1.4 (.65)
3898	3/4" M x 1" F Single Plane Swivel	1.4 (.65)
8517	1" M x 1" M Single Plane Swivel	1.4 (.65)

BSPP Threads

MODEL NO.	DESCRIPTION	SHIPPING WEIGHT LBS (KG)
3760	3/4" M x 1" F Single Plane Swivel	1.4 (.65)
3830	1" M x 1" F Single Plane Swivel	1.4 (.65)

Construction

Body	Aluminum
Inner Seal	Fluorosilicone
Outer Seal	Fluorosilicone





For standard fueling applications.

Dimensions

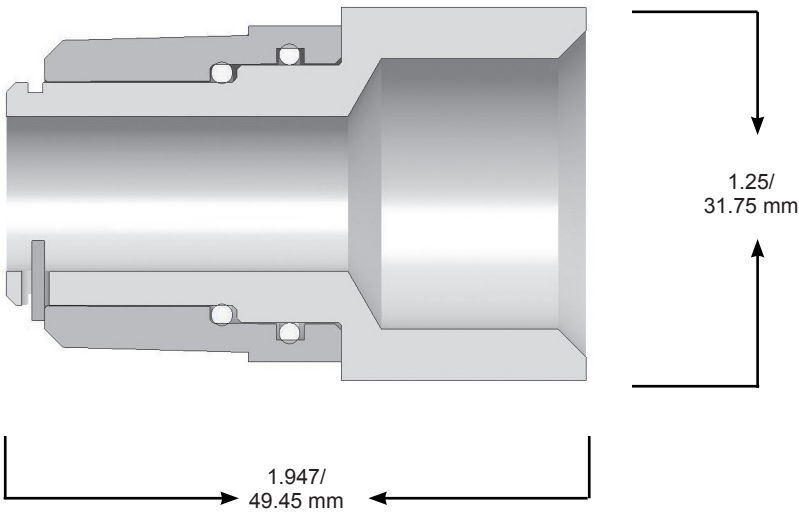



For standard farming applications.

All Husky Multi-Plane Swivels

- Compatible with unlead, diesel, and Ethanol blends through E10.
 - Compact and light weight for easy handling.
 - High flow rates due to laminar flow design.
 - High strength step shoulder bearing diameters and impact absorbing stops.
- Model 2950 Restricted Swivel**
- Multi-Plane, 210° spherical rotation at the swivel nut.
 - Double o-ring seals at each swivel provide long life at low temperatures (-40° F/C).

All Weather Swivels

- Multi-Plane, Full 360° spherical rotation for easy movement of nozzle.
- Double o-ring seals at each swivel provide long life at low temperatures (-40° F/C).

Warm Weather Swivels

- Multi-Plane, Full 360° spherical rotation for easy movement of nozzle.
- Double o-ring seals at each swivel provide long life at high temperatures (482° F / 250° C).



Model 0352



Model 0350



Model 2272

All Weather NPTF

MODEL NO.	DESCRIPTION	SHIPPING WEIGHT LBS (KG)
0350	3/4" M x 3/4" F Swivel	.50 (.22)
0352	1" M x 3/4" F Swivel	.66 (.29)
0355	3/4" M x 3/4" F Black Swivel	.49 (.22)
0356	1" M x 3/4" F Black Swivel	.66 (.29)
2272	3/4" M x 3/4" F 90° Swivel	.38 (.17)
2950	3/4" M x 3/4" F Restricted Swivel	.50 (.22)

Warm Weather NPTF

MODEL NO.	DESCRIPTION	SHIPPING WEIGHT LBS (KG)
0350W	3/4" M x 3/4" F Swivel	.50 (.22)
0352W	1" M x 3/4" F Swivel	.66 (.29)

All Weather BSPP

MODEL NO.	DESCRIPTION	SHIPPING WEIGHT LBS (KG)
1491	3/4" M x 3/4" F BSPT Swivel	.50 (.22)
3590	3/4" M x 3/4" F BSPP Swivel	.60 (.27)
3590A	3/4" M X 3/4" F BSPP Swivel with Atex Certification	.60 (.27)
2771	3/4" M x 3/4" F 90° BSPP Swivel	.38 (.17)

Warm Weather BSPP

MODEL NO.	DESCRIPTION	SHIPPING WEIGHT LBS (KG)
3590W	3/4" M x 3/4" F BSPP Swivel	.60 (.27)

Construction

ALL WEATHER

Body	High Aluminum Zinc Alloy
Inner O-ring	Fluorosilicone
Outer O-ring	Fluorocarbon

WARM WEATHER

Body	High Aluminum Zinc Alloy
Inner O-ring	Fluorocarbon
Outer O-ring	Fluorocarbon

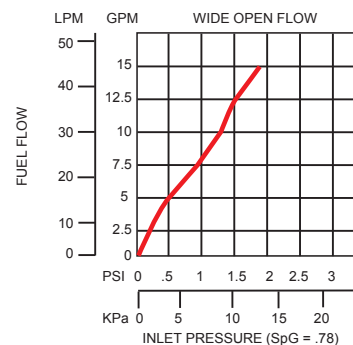
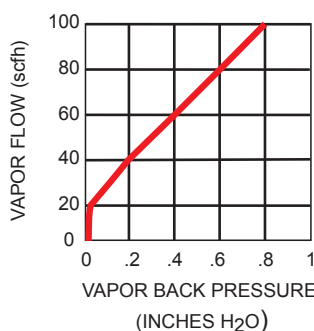



For standard farming applications.

Dimensions

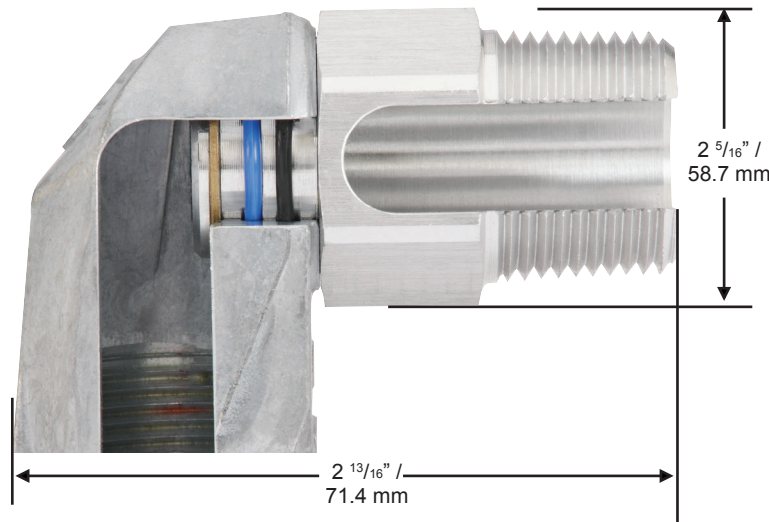
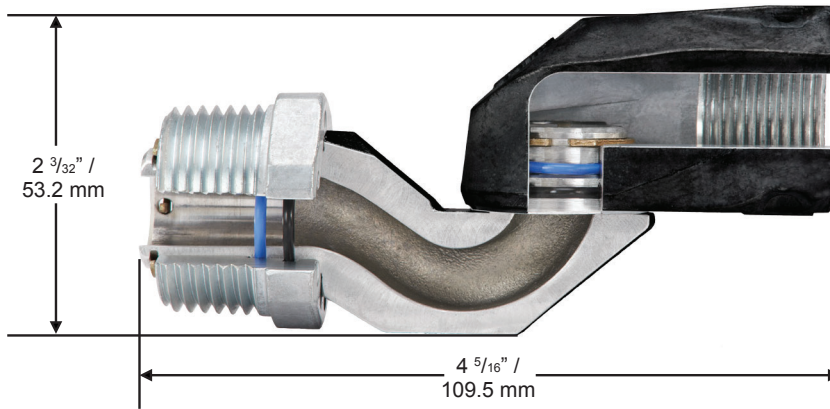
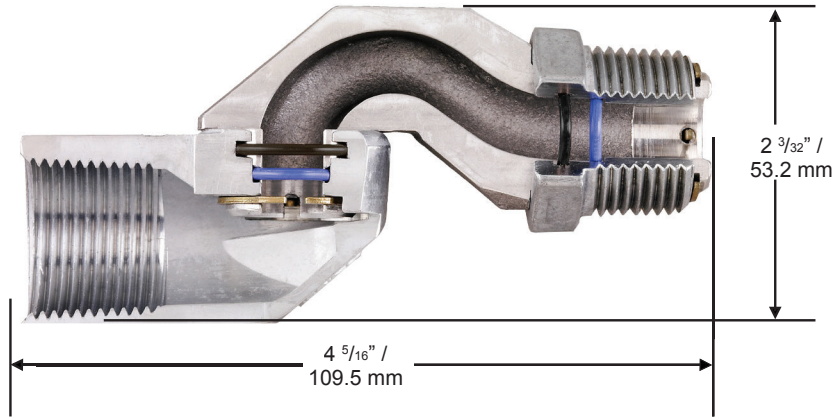

For truck and high volume fueling.

All Husky Multi-Plane Swivels

- Compatible with diesel fuels and Ethanol blends through E10.
- Compact and light weight for easy handling.
- High flow rates due to laminar flow design.
- High strength step shoulder bearing diameters and impact absorbing stops.
- Double o-ring seals at each swivel provide long life at low temperatures (-40° F/C).

Husky High Volume Multi-Plane Swivels

- Multi-Plane, Full 360° spherical rotation for easy movement of nozzle.

- For use with high flow nozzles with flow rates up to 100 gpm/ 378 Lpm.
- Raised stainless steel ball bearings provide easy joint movement, greatly improving ease of swivel when used on higher pressure systems.
- 75% less back pressure.

Husky Multi-Plane Restricted Swivels

- Multi-Plane, 210° spherical rotation at the swivel nut.

Warm Weather Swivels

- Multi-Plane, Full 360° spherical rotation for easy movement of nozzle.
- Double o-ring seals at each swivel provide long life at high temperatures (482° F / 250° C).



NPTF Threads

MODEL NO.	DESCRIPTION	SHIPPING WEIGHT LBS (KG)
0087	1" M x 1" F Swivel	.96 (.43)
0087W	1" M x 1" F Swivel with Warm Weather Seals	.96 (.43)
4860	1" M x 1" F High Flow Swivel	1.4 (.63)
0095	1" M x 1" F 70° Pump Swivel	.76 (.34)
3395	1" M x 1" F Restricted Swivel	.93 (.42)

BSPP Threads

MODEL NO.	DESCRIPTION	SHIPPING WEIGHT LBS (KG)
3306	1" M x 1" F Swivel	1.1 (.49)
3306W	1" M x 1" F Swivel with Warm Weather Seals	1.1 (.49)
6949	1" M x 1" F High Flow Swivel	1.1 (.49)
7254	1" M x 1" F Restricted Swivel	.93 (.42)

BSPT Threads

MODEL NO.	DESCRIPTION	SHIPPING WEIGHT LBS (KG)
1670	1" M x 1" F Swivel	.93 (.42)

CONSTRUCTION

STANDARD

Body	High Aluminum Zinc Alloy
Inner O-ring	Fluorosilicone
Outer O-ring	Fluorocarbon

WARM WEATHER

Body	High Aluminum Zinc Alloy
Inner O-ring	Fluorocarbon
Outer O-ring	Fluorocarbon

HIGH VOLUME

Body	Aluminum, Zinc and Zinc Plated Steel
Inner O-ring	Fluorosilicone
Outer O-ring	Fluorocarbon

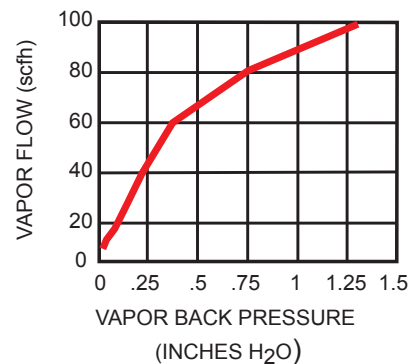

For truck and high volume fueling.

Dimensions

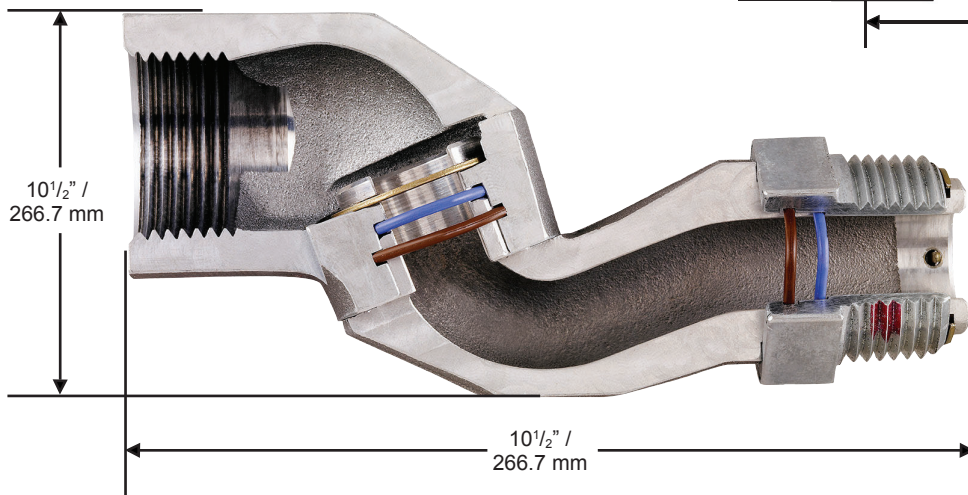
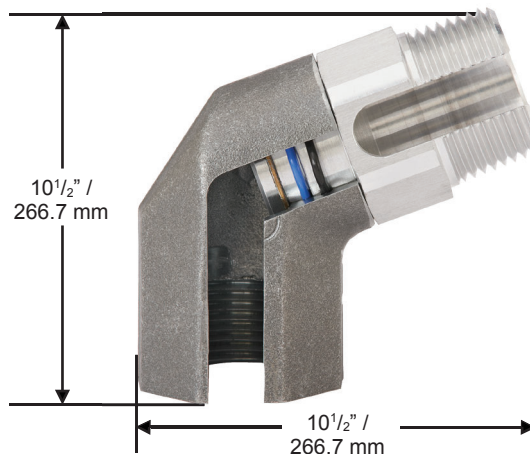
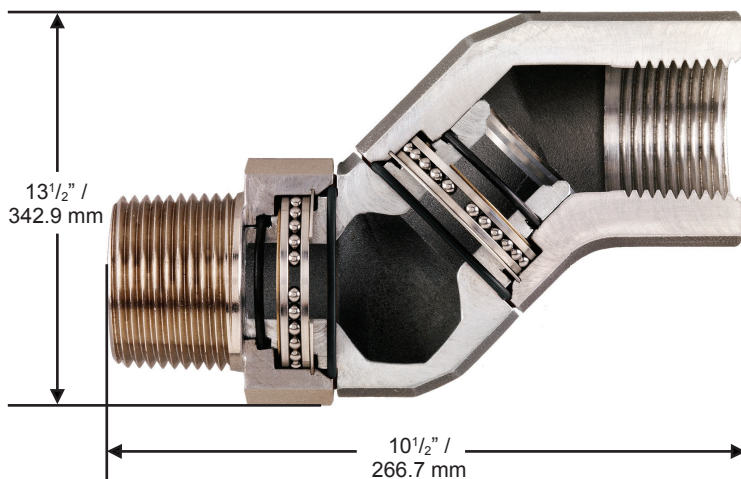

MADE IN THE U.S.A. 

4605 Vapor Recovery Swivel is compatible with most vacuum assist vapor recovery systems.

- 360° rotation at each swivel joint.
- Double o-rings at each swivel joint.
- Can be installed at the nozzle or at the dispenser.
- Stainless steel ball bearings and races allow for easy joint movement and reduces friction, thus extending the life of the swivel.
- Has 2 (two) plane rotation.
- Exceptional flow rate and reduced back pressure.
- Lightweight and compact.

New Swivels

MODEL NO.	DESCRIPTION	SHIPPING WEIGHT LBS (KG)
4605	M34 x 1.5" Vapor Swivel	1.0 (.45)
4605A	M34 x 1.5" Vapor Swivel with Atex approval	1.0 (.45)

Construction

Body	Zinc
Inlet Body	Aluminum
Swivel Nut	Electroless, Nickel Plated Aluminum
Seals	Fluorocarbon
Threads	M34 x 1.5"

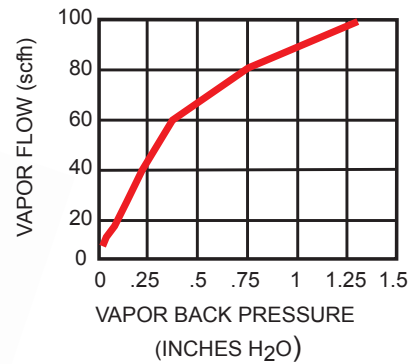

California Environmental Protection Agency
AIR RESOURCES BOARD

4605 Vapor Recovery Swivel is compatible with most vacuum assist vapor recovery systems.

Dimensions

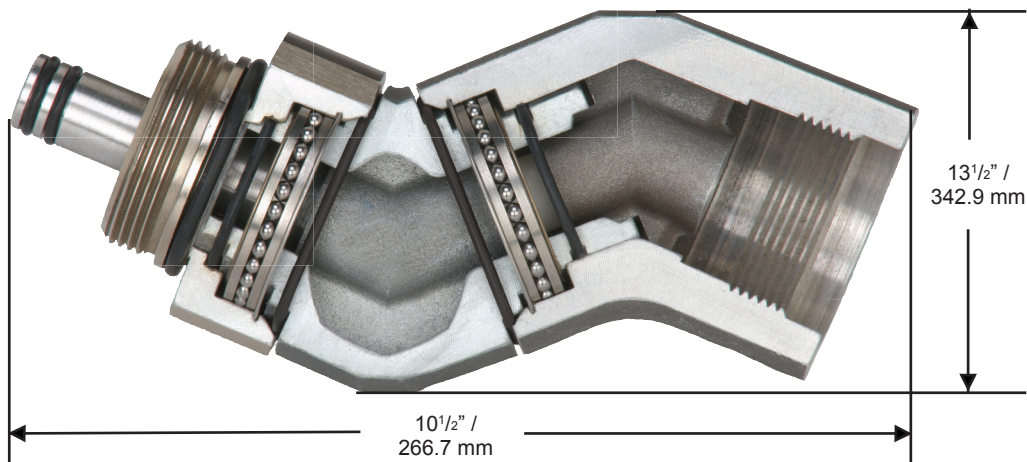

Husky high volume delivery swivels make it easier to manipulate the long, heavy hoses used on bulk delivery systems.

- Relieves kinking and twisting of hose.
- Unique stainless steel ball bearing design provides easier joint movement during high pressure applications.
- Easier to angle the nozzle into fill openings.

Model 5265



NPTF Threads

MODEL NO.	DESCRIPTION	SHIPPING WEIGHT LBS (KG)
5235	1/4" F x 1/4" M Single Plane Swivel	1.4 (.65)
5240	1/4" F x 1/2" M Single Plane Swivel	1.4 (.65)
5265	1/2" F x 1/4" M Single Plane Swivel	1.4 (.65)
5266	1/2" F x 1/2" M Single Plane Swivel	1.4 (.65)

BSPF Threads

MODEL NO.	DESCRIPTION	SHIPPING WEIGHT LBS (KG)
5754	1/4" F x 1/2" M Single Plane Swivel	1.4 (.65)
5755	1/2" F x 1/2" M Single Plane Swivel	1.4 (.65)

Construction

Body	Aluminum
Seals	Fluorocarbon

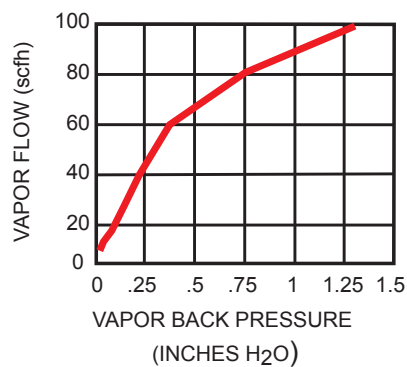

Husky high volume delivery swivels make it easier to manipulate the long, heavy hoses used on bulk delivery systems.

Dimensions

Model 5235, 5240, 5265 and 5266

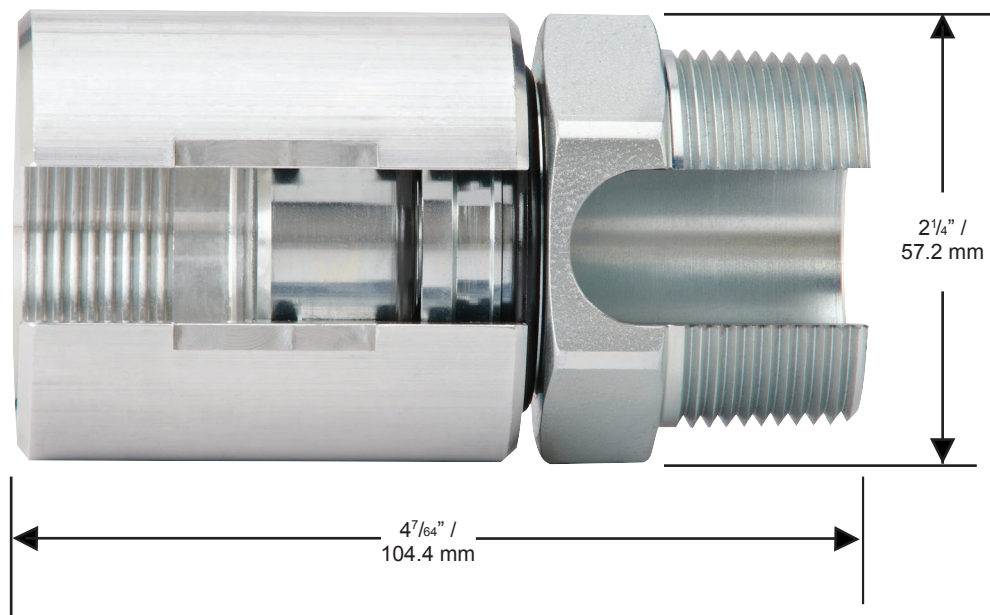



For truck and high volume fueling.

All Husky Multi-Plane Swivels

- Compatible with diesel fuels and Ethanol blends through E10.
- Compact and light weight for easy handling.
- High flow rates due to laminar flow design.
- High strength step shoulder bearing diameters and impact absorbing stops.
- Double o-ring seals at each swivel provide long life at low temperatures (-40° F/C).

Husky High Volume Multi-Plane Swivels

- Multi-Plane, Full 360° spherical rotation for easy movement of nozzle.

- For use with high flow nozzles with flow rates up to 100 gpm/ 378 Lpm.
- Raised stainless steel ball bearings provide easy joint movement, greatly improving ease of swivel when used on higher pressure systems.
- 75% less back pressure.

Husky Multi-Plane Restricted Swivels

- Multi-Plane, 210° spherical rotation at the swivel nut.

Warm Weather Swivels

- Multi-Plane, Full 360° spherical rotation for easy movement of nozzle.
- Double o-ring seals at each swivel provide long life at high temperatures (482° F / 250° C).

NPTF Threads

MODEL NO.	DESCRIPTION	SHIPPING WEIGHT LBS (KG)
0087	1" M x 1" F Swivel	.96 (.43)
0087W	1" M x 1" F Swivel with Warm Weather Seals	.96 (.43)
4860	1" M x 1" F High Flow Swivel	1.4 (.63)
0095	1" M x 1" F 70° Pump Swivel	.76 (.34)
3395	1" M x 1" F Restricted Swivel	.93 (.42)

BSPP Threads

MODEL NO.	DESCRIPTION	SHIPPING WEIGHT LBS (KG)
3306	1" M x 1" F Swivel	1.1 (.49)
3306W	1" M x 1" F Swivel with Warm Weather Seals	1.1 (.49)
6949	1" M x 1" F High Flow Swivel	1.1 (.49)
6949A*	1" M x 1" F High Flow Swivel with Atex certification	1.1 (.49)
7254	1" M x 1" F Restricted Swivel	.93 (.42)

BSPT Threads

MODEL NO.	DESCRIPTION	SHIPPING WEIGHT LBS (KG)
1670	1" M x 1" F Swivel	.93 (.42)

CONSTRUCTION

STANDARD

Body	High Aluminum Zinc Alloy
Inner O-ring	Fluorosilicone
Outer O-ring	Fluorocarbon

WARM WEATHER

Body	High Aluminum Zinc Alloy
Inner O-ring	Fluorocarbon
Outer O-ring	Fluorocarbon

HIGH VOLUME

Body	Aluminum, Zinc and Zinc Plated Steel
Inner O-ring	Fluorosilicone
Outer O-ring	Fluorocarbon

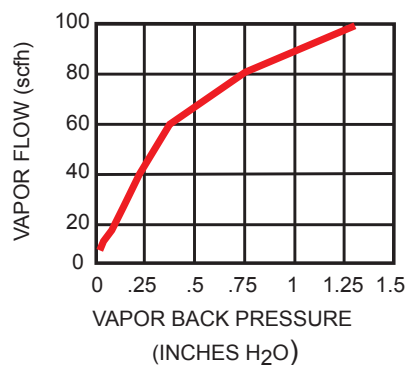
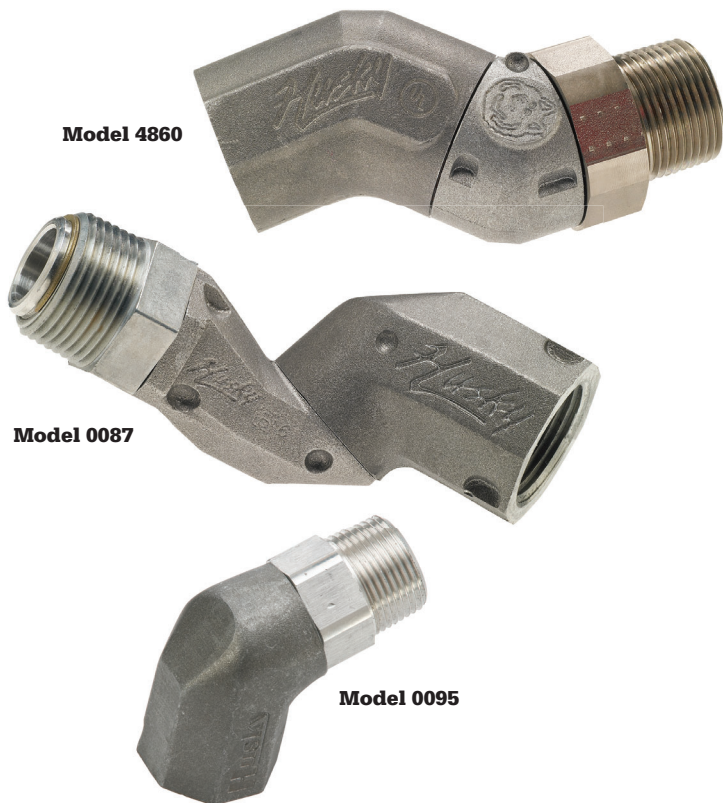

For truck and high volume fueling.

Dimensions

Model 0087, 0087W, 3306, 3395 and 7254

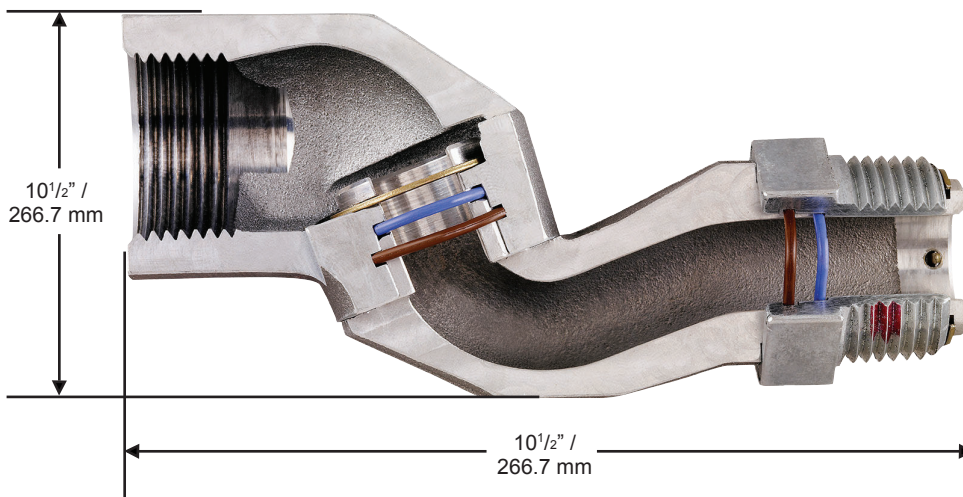

Model 4860 and 6949

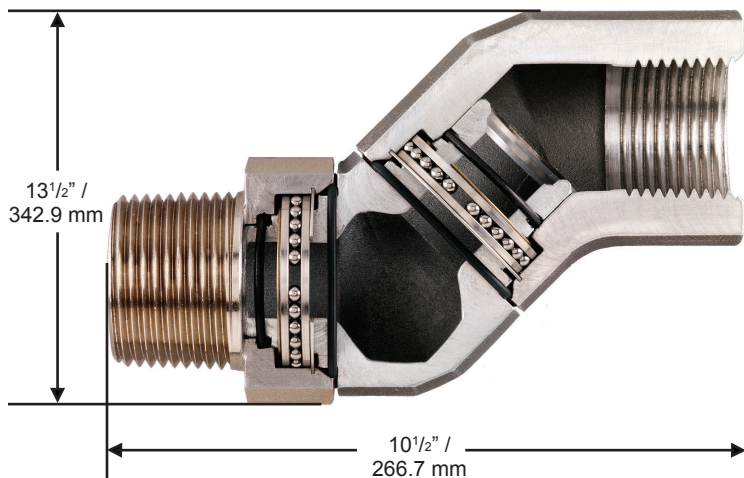

Model 0095

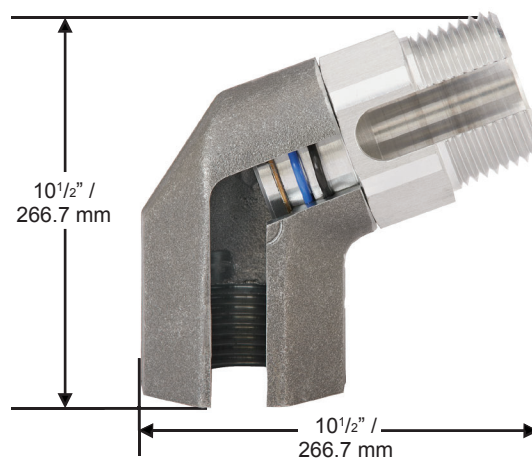

Diesel Exhaust Fluid Inline Swivels.

- Full 360° rotation for easy movement of nozzle.
- Relieves kinking and twisting of the hose.
- High flow rate featuring laminar flow design.
- Compact for easy handling.
- Unique to Husky products, the steel ball bearing design provides easier joint movement during high pressure applications.

DEF Swivels

MODEL NO.	DESCRIPTION	SHIPPING WEIGHT LBS (KG)
7269	1" M x 1" M BSPP Inline Swivel	.60 (.27)
7275	1" M BSPP x M34 M Inline Swivel	.62 (.28)
7282	¾" M BSPP x ¾" Hose Barb Inline Swivel	.42 (.19)
7467	1" F x 1" M BSPP Inline Swivel	.66 (.30)
8510	1" M BSPP x 1" F NPTF (25.4 mm M x 25.4 mm F) Inline Swivel	.66 (.30)

Construction

Body	Stainless Steel
Seals	Fluorocarbon

Part 7269



Part 7467



Part 7279



Part 7282

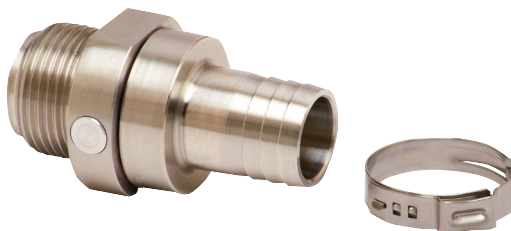

Diesel Exhaust Fluid Inline Swivels.

Dimensions

Part 7269

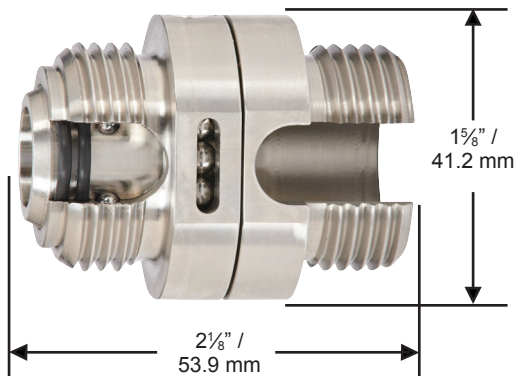

Part 7282



Part 7467

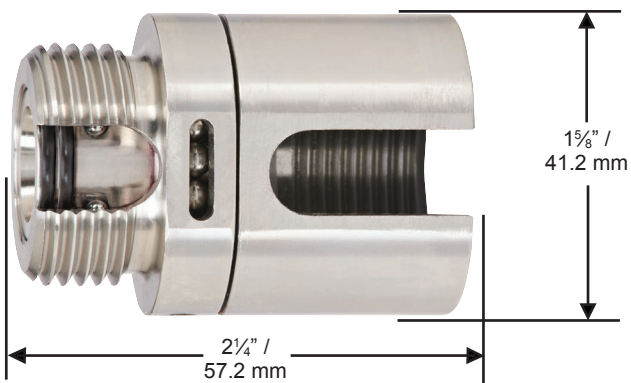

Part 7275

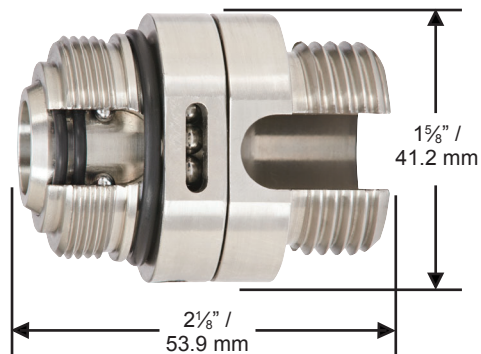

E85 Swivel



Husky Model 6350 Multi-Plane Swivel.

- Multi-Plane, Full 360° spherical rotation for easy movement of nozzle.
- Compact and light weight for easy handling.
- Double o-ring seals at each swivel provide long life and low temperature (-40° F/C) performance.
- Compatible with unlead, diesel, and all Ethanol blends through E100.
- High strength step shoulder bearing diameters and impact absorbing stops.
- Compatible with fuels containing alcohol.
- High flow rate due to laminar flow design.

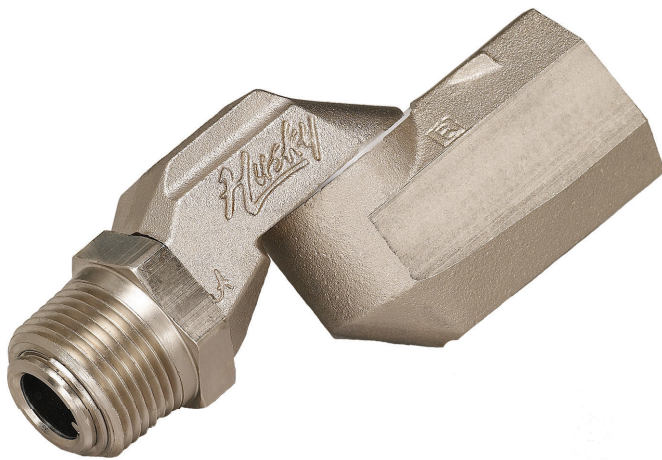

Swivels

MODEL NO.	DESCRIPTION	SHIPPING WEIGHT LBS (KG)
6350	¾" M x ¾" F Multi-Plane Swivel	.44 (.19)

Construction

Body	Aluminum with Electroless Nickel Plating
Inner O-ring	Fluorosilicone
Outer O-ring	Fluorocarbon
Threads	¾" / 19.1 mm NPTF

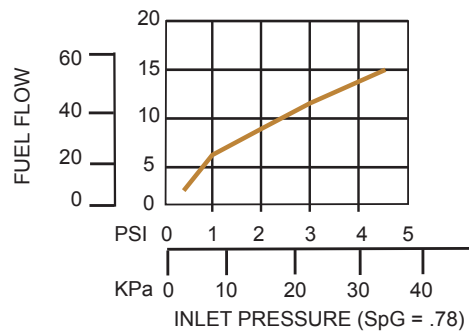

Husky Model 6350 Multi-Plane Swivel.

Dimensions

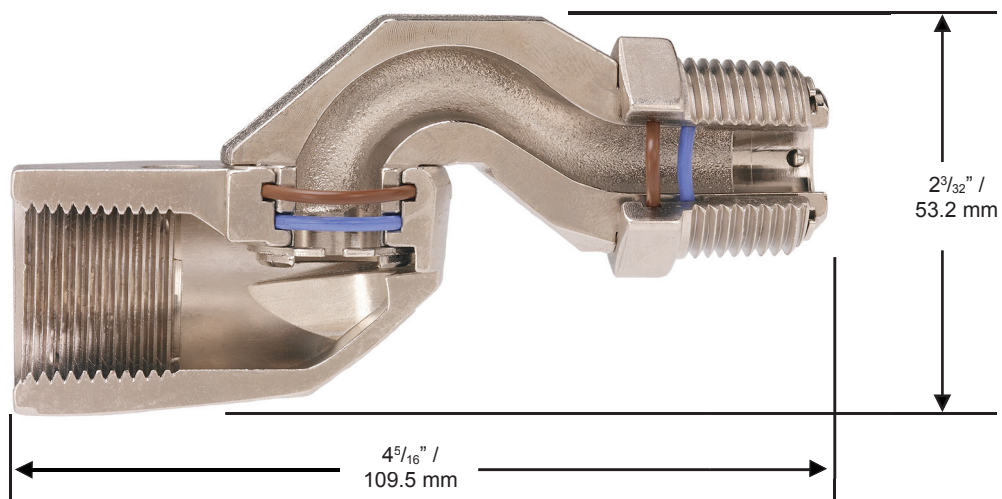



Husky

GENERAL FUELING PRODUCTS

Safe-T-Breaks®

All Husky Safe-T-Breaks® stop the flow of fuel on both sides of the separation and have passed the demanding UL test requirements on separations without leaking or failing.

Models 3360 and 3385

- Retains UL listing after reconnection.
- Features a pre-loaded spring and a single turn wave spring that enables valve to resist sudden pressure build-up in the hose causing nuisance separations.
- Separates at less than 200 lbf / 889.6 N which minimizes “backlash” force of separation, reducing damage to equipment.

Model 5230

- Retains UL listing after reconnection.
- Uses the same pre-loaded spring and a single turn wave spring as Model 3360.
- Separates at less than 115 lbf / 511.5 N.

Model 2273 & 2774

- Light-weight, inexpensive and disposable.
- Same instant-closing dual poppet check valve design as Model 3360.
- Separates at less than 300 lbf / 1334.4 N.

Model 6130

- Internal Pressure Compensating Chamber (PCC) that prevents “line shock” nuisance separations.
- Same instant-closing dual poppet check valve as Model 3360.
- Separates at less than 225 lbf / 1000.8 N.

Reconnectable with NPTF

MODEL NO.	DESCRIPTION	SHIPPING WEIGHT LBS (KG)
3360*	¾" F x ¾" F Reconnectable Safe-T-Break® with scuff guard	0.59 (0.26)
5230*	¾" F x ¾" F Reconnectable Low-Pull Safe-T-Break® with scuff guard	0.59 (0.26)

Non-reconnectable with NPTF

MODEL NO.	DESCRIPTION	SHIPPING WEIGHT LBS (KG)
2273	¾" F x ¾" F Non-Reconnectable Safe-T-Break®	0.78 (0.35)
6130*	¾" F x ¾" F PCC Non-Reconnectable Safe-T-Break® with scuff guard	0.52 (0.23)

Reconnectable with BSPP

MODEL NO.	DESCRIPTION	SHIPPING WEIGHT LBS (KG)
3385*	¾" F x ¾" F Reconnectable Safe-T-Break® with scuff guard	0.57 (0.25)

Non-reconnectable with BSPP

MODEL NO.	DESCRIPTION	SHIPPING WEIGHT LBS (KG)
2774	¾" F x ¾" F Non-Reconnectable Safe-T-Break®	0.73 (0.33)
2774A	¾" F x ¾" F Non-Reconnectable Safe-T-Break® - Atex	0.73 (0.33)

*See page 2 for guard color options



Model 3600



Model 6130



Model 2273

Construction

RECONNECTABLE SAFE-T-BREAKS®

Body	Aluminum
Seals	Fluorocarbon
Springs	Stainless Steel Stainless steel load and latch spring reverse mechanism Hardened stainless steel latch ring and balls

NON-RECONNECTABLE SAFE-T-BREAKS®

Body	Zinc Alloys and Aluminum
------	--------------------------

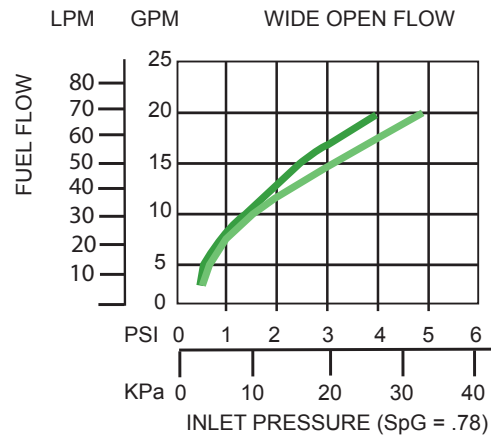

**Husky**

GENERAL FUELING PRODUCTS

Standard **STB**

All Husky Safe-T-Breaks® stop the flow of fuel on both sides of the separation and have passed the demanding UL test requirements on separations without leaking or failing.

Dimensions and System Options

Whip Hoses

MODEL NO.	DESCRIPTION
NPTF THREADS	
2274	3/4" M x 3/4" M (19 mm M x 19 mm M) Whip Hose
227374	3/4" M x 3/4" M (19 mm M x 19 mm M) Whip Hose connected to Model 2273 3/4" F x 3/4" F Non-Reconnectable Safe-T-Break®
336074*	3/4" M x 3/4" M (19 mm M x 19 mm M) Whip Hose connected to Model 3360 3/4" F x 3/4" F Reconnectable Safe-T-Break®
2275	3/4" M x 3/4" M (19 mm M x 19 mm M) Whip Hose with Swivel Nut
227375*	3/4" M x 3/4" M (19 mm M x 19 mm M) Whip Hose with Swivel Nut connected to Model 2273 3/4" F x 3/4" F Non-Reconnectable Safe-T-Break®
336075*	3/4" M x 3/4" M (19 mm M x 19 mm M) Whip Hose with Swivel Nut connected to Model 3360 3/4" F x 3/4" F Reconnectable Safe-T-Break®
BSPP THREADS	
2775	3/4" M x 3/4" M (19 mm M x 19 mm M) Whip Hose

Guards

MODEL NO.	DESCRIPTION
3096*	Scuff Guard for Model #3360, 6130 & 5230
6503*	Dispenser Scuff Guard for Model #2273 and 2774

Accessories, Testing and Maintenance

MODEL NO.	DESCRIPTION
7000	Safe-T-Break® Drain Cup
3813	Safe-T-Break® Demonstration Kit

Color Chart

COLOR	SUFFIX	COLOR	SUFFIX
Blue	-01	White	-06
Red	-02	Gold	-08
Green	-03	Silver	-09
Black	-04	BP Green	-16
Yellow	-05	Pink	-20

*Safe-T-Breaks® and Safe-T-Break® Scuff Guards are to be ordered with the corresponding guard color option added to the model number.

Example: If BLUE guards are desired, add guard color option -01 to the model number (4034-01).

For custom colors, a minimum order of 4,000 guards will be required.

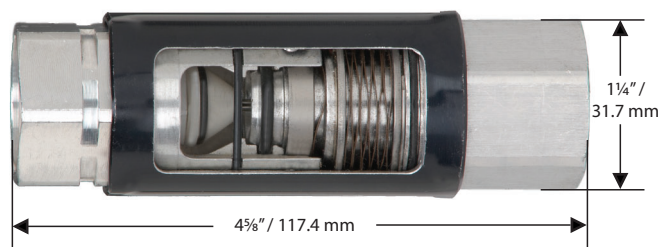
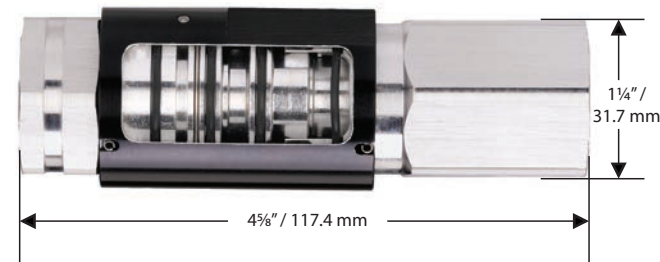
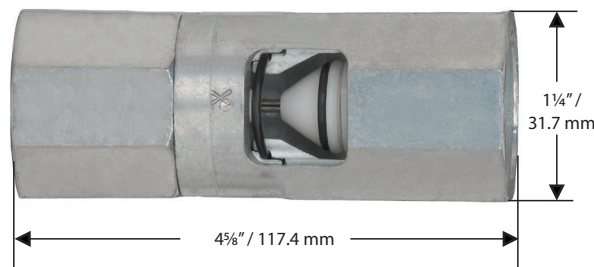
Model 3360**Model 6130****Model 2273**

MADE IN THE U.S.A.



Patent pending magnetic separation and reconnect mechanism.

- High impact resistant polymer housing.
- 3/4" or 1" Female NPT inlets.
- Available in 3/4" or 1" Female BSP threads.
- 1" MAGBREAK® has lower back pressure than competing magnetic breakaways. Lower back pressure means higher flow rates.
- 3/4"-pound lighter than competing magnetic breakaways.
- Two straight screwdrivers used to separate.
- Easier "separate to inspect" method than competition.
- Assurance of proper reconnection using a simple "twist of lock" feature.
- Absorb line shock in excess of 450 psi at 17 gpm (31 bar at 64.3 Lpm)
- Low scuff housing.
- Line shock absorbing design.
- Stops flow on both sides of break.

New MAGBREAK®

MODEL NO.	DESCRIPTION	SHIPPING WEIGHT LBS (KG)
8330	MAGBREAK® 3/4" F NPT (Separates at less than 200 pounds pull force)	1.21 (.55)
8331	MAGBREAK® 1" F NPT CK	1.09 (.50)
10328	MAGBREAK® 3/4" F NPT CK (Separates at less than 225 pounds pull force)	1.21 (.55)

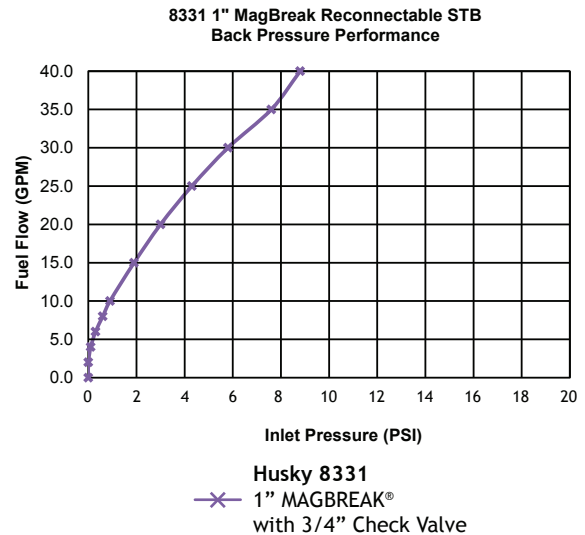
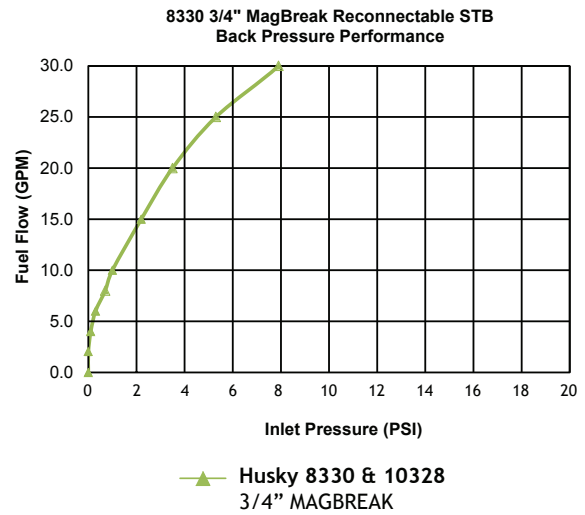

Patent pending magnetic separation and reconnect mechanism.

Dimensions

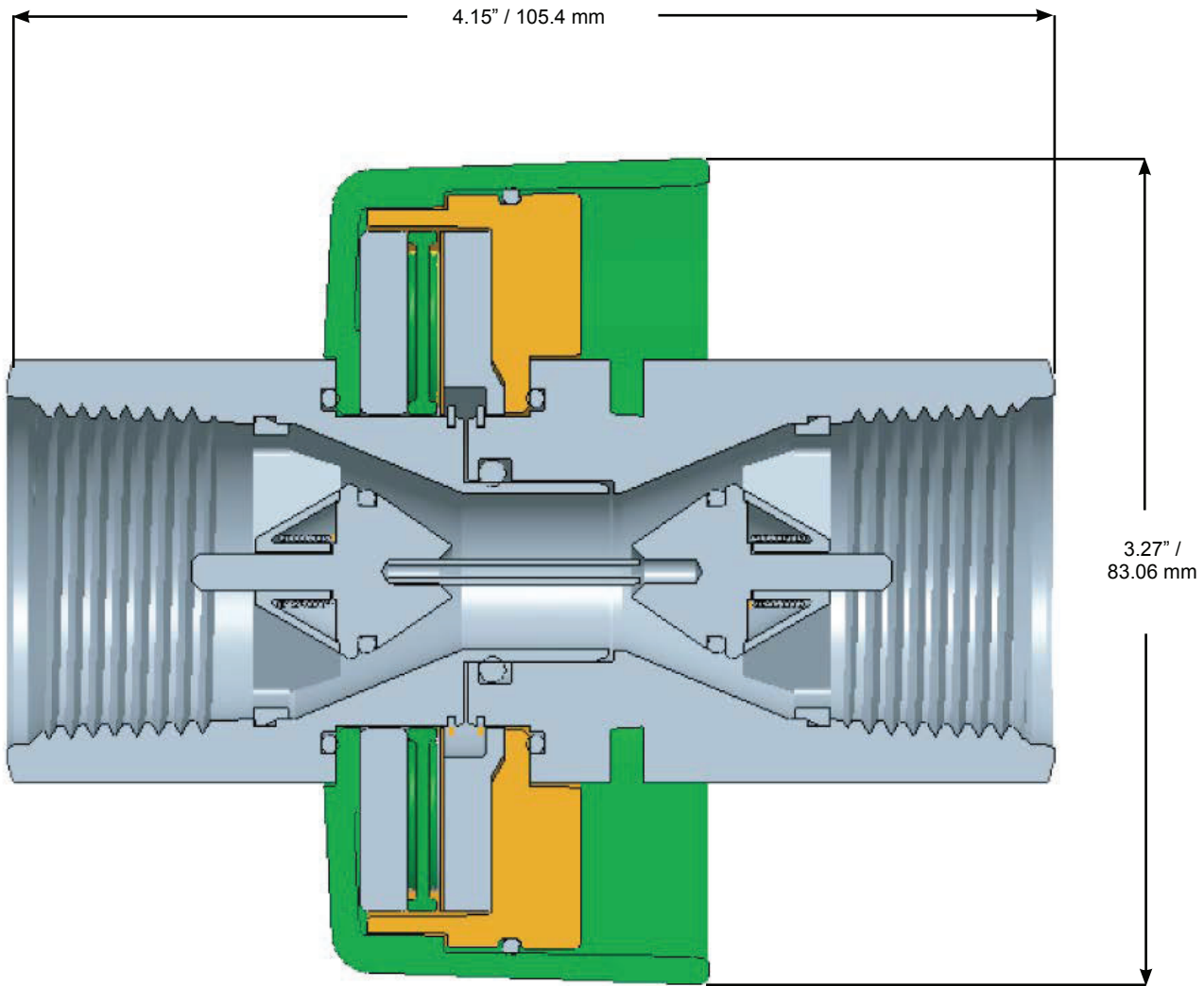

All Husky Safe-T-Breaks® stop the flow of fuel on both sides of the separation and have passed the demanding UL test requirements on separations without leaking or failing.

Models 3360 and 3385

- Retains UL listing after reconnection.
- Features a pre-loaded spring and a single turn wave spring that enables valve to resist sudden pressure build-up in the hose causing nuisance separations.
- Separates at less than 200 lbf / 889.6 N which minimizes “backlash” force of separation, reducing damage to equipment.

Model 5230

- Retains UL listing after reconnection.
- Uses the same pre-loaded spring and a single turn wave spring as Model 3360.
- Separates at less than 115 lbf / 511.5 N.

Model 2273 & 2774

- Light-weight, inexpensive and disposable.
- Same instant-closing dual poppet check valve design as Model 3360.
- Separates at less than 300 lbf / 1334.4 N.

Model 6130

- Internal Pressure Compensating Chamber (PCC) that prevents “line shock” nuisance separations.
- Same instant-closing dual poppet check valve as Model 3360.
- Separates at less than 225 lbf / 1000.8 N.

Reconnectable with NPTF

MODEL NO.	DESCRIPTION	SHIPPING WEIGHT LBS (KG)
3360*	¾" F x ¾" F Reconnectable Safe-T-Break® with scuff guard	0.59 (0.26)
5230*	¾" F x ¾" F Reconnectable Low-Pull Safe-T-Break® with scuff guard	0.59 (0.26)

Non-reconnectable with NPTF

MODEL NO.	DESCRIPTION	SHIPPING WEIGHT LBS (KG)
2273	¾" F x ¾" F Non-Reconnectable Safe-T-Break®	0.78 (0.35)
6130*	¾" F x ¾" F PCC Non-Reconnectable Safe-T-Break® with scuff guard	0.52 (0.23)

Reconnectable with BSPP

MODEL NO.	DESCRIPTION	SHIPPING WEIGHT LBS (KG)
3385*	¾" F x ¾" F Reconnectable Safe-T-Break® with scuff guard	0.57 (0.25)

Non-reconnectable with BSPP

MODEL NO.	DESCRIPTION	SHIPPING WEIGHT LBS (KG)
2774	¾" F x ¾" F Non-Reconnectable Safe-T-Break®	0.73 (0.33)
2774A	¾" F x ¾" F Non-Reconnectable Safe-T-Break® - Atex	0.73 (0.33)

*See page 2 for guard color options



Model 3600



Model 6130



Model 2273

Construction

RECONNECTABLE SAFE-T-BREAKS®

Body	Aluminum
Seals	Fluorocarbon
Springs	Stainless Steel Stainless steel load and latch spring reverse mechanism Hardened stainless steel latch ring and balls

NON-RECONNECTABLE SAFE-T-BREAKS®

Body	Zinc Alloys and Aluminum
------	--------------------------

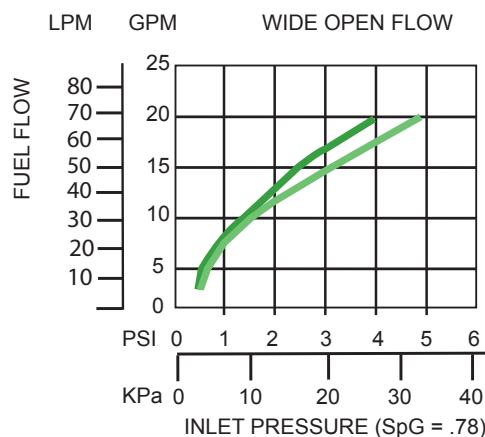

**Husky**

GENERAL FUELING PRODUCTS

F&C Standard STB

All Husky Safe-T-Breaks® stop the flow of fuel on both sides of the separation and have passed the demanding UL test requirements on separations without leaking or failing.

Dimensions and System Options

Whip Hoses

MODEL NO.	DESCRIPTION
NPTF THREADS	
2274	¾" M x ¾" M (19 mm M x 19 mm M) Whip Hose
227374	¾" M x ¾" M (19 mm M x 19 mm M) Whip Hose connected to Model 2273 ¾" F x ¾" F Non-Reconnectable Safe-T-Break®
336074*	¾" M x ¾" M (19 mm M x 19 mm M) Whip Hose connected to Model 3360 ¾" F x ¾" F Reconnectable Safe-T-Break®
BSPP THREADS	
2275	¾" M x ¾" M (19 mm M x 19 mm M) Whip Hose with Swivel Nut
227375*	¾" M x ¾" M (19 mm M x 19 mm M) Whip Hose with Swivel Nut connected to Model 2273 ¾" F x ¾" F Non-Reconnectable Safe-T-Break®
336075*	¾" M x ¾" M (19 mm M x 19 mm M) Whip Hose with Swivel Nut connected to Model 3360 ¾" F x ¾" F Reconnectable Safe-T-Break®

Guards

MODEL NO.	DESCRIPTION
3096*	Scuff Guard for Model #3360, 6130 & 5230
6503*	Dispenser Scuff Guard for Model #2273 and 2774

Accessories, Testing and Maintenance

MODEL NO.	DESCRIPTION
7000	Safe-T-Break® Drain Cup
3813	Safe-T-Break® Demonstration Kit

Color Chart

COLOR	SUFFIX	COLOR	SUFFIX
Blue	-01	White	-06
Red	-02	Gold	-08
Green	-03	Silver	-09
Black	-04	BP Green	-16
Yellow	-05	Pink	-20

*Safe-T-Breaks® and Safe-T-Break® Scuff Guards are to be ordered with the corresponding guard color option added to the model number.

Example: If BLUE guards are desired, add guard color option -01 to the model number (4034-01).

For custom colors, a minimum order of 4,000 guards will be required.

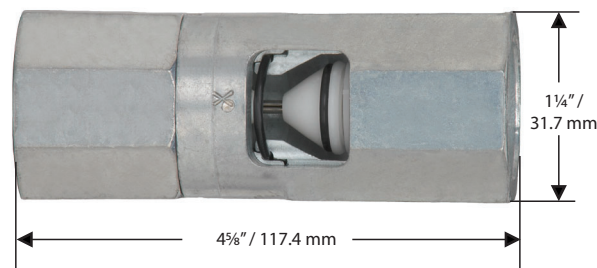
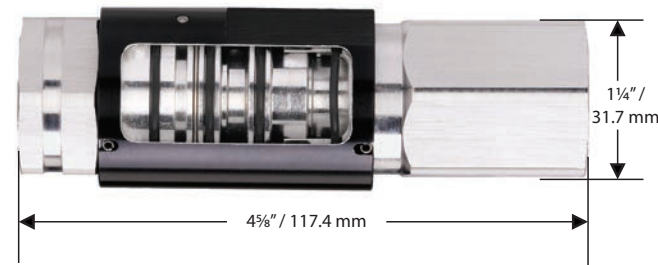
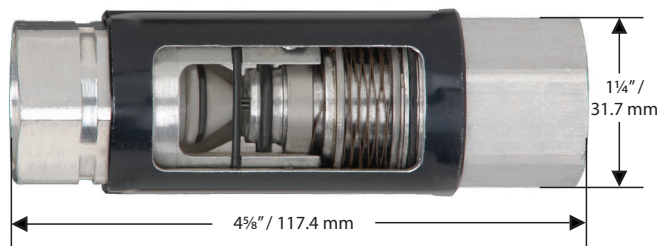

MADE IN THE U.S.A.

High Volume STB



All Husky Safe-T-Breaks® stop the flow of fuel on both sides of the separation and have passed the demanding UL test requirements on separations without leaking or failing.

Models 2276, 3076 and 3076A

- Retains UL listing after reconnection.
- Internal pressure balancing chamber prevents “line shock” nuisance separations.
- Separates at less than 200 lbf / 889.6 N which minimizes “backlash” force of separation, reducing damage to equipmen.

Model 5231

- Retains UL listing after reconnection.
- Uses the same internal pressure balancing chamber as Model #2276.
- Separates at less than 115 lbf / 511.5 N.

Model 5812 and 6914

- Light-weight, inexpensive and disposable.
- Same instant-closing dual poppet check valve design as Model 2276.
- Separates at less than 300 lbf / 1334.4 N.

Model 6301

- Internal Pressure Compensating Chamber (PCC) that prevents “line shock” nuisance separations.
- Same instant-closing dual poppet check valve as Model 2276.
- Separates at less than 225 lbf / 1000.8 N.

Reconnectable with NPTF

MODEL NO.	DESCRIPTION	SHIPPING WEIGHT LBS (KG)
2276*	1" F x 1" F Reconnectable Safe-T-Break®	.75 (.34)
5231*	1" F x 1" F Reconnectable Low-Pull Safe-T-Break®	.75 (.34)

Non-reconnectable with NPTF

MODEL NO.	DESCRIPTION	SHIPPING WEIGHT LBS (KG)
5812*	1" F x 1" F Non-Reconnectable Safe-T-Break®	.61 (.27)
6301*	1" F x 1" F PCC Non-Reconnectable Safe-T-Break®	.69 (.31)

Reconnectable with BSPP

MODEL NO.	DESCRIPTION	SHIPPING WEIGHT LBS (KG)
3076*	1" F x 1" F Reconnectable Safe-T-Break®	.75 (.34)
3076A*	1" F x 1" F Reconnectable Safe-T-Break® - Atex	.75 (.34)

Non-reconnectable with BSPP

MODEL NO.	DESCRIPTION	SHIPPING WEIGHT LBS (KG)
6914*	1" F x 1" F Non-Reconnectable Safe-T-Break®	.61 (.27)

*See page 2 for guard color options



Model 2276



Model 5812

Construction

Reconnectable Safe-T-Breaks®

Body	Aluminum
Seals	Fluorocarbon
Springs	Stainless Steel
Stainless steel load and latch spring reverse mechanism	
Hardened stainless steel latch ring and balls	

Non-Reconnectable Safe-T-Breaks®

Body	Zinc Alloys and Aluminum
Seals	Fluorocarbon

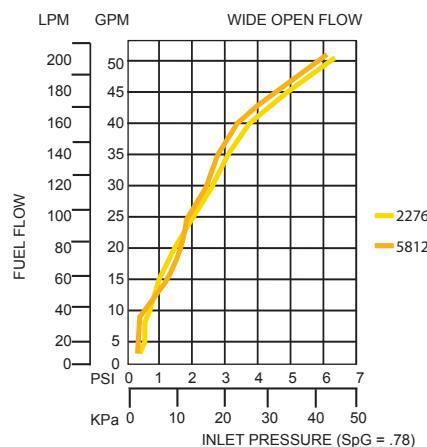



High Volume STB

All Husky Safe-T-Breaks® stop the flow of fuel on both sides of the separation and have passed the demanding UL test requirements on separations without leaking or failing.

Dimensions and System Options

Whip Hoses

MODEL NO.	DESCRIPTION
2277	1" M x 1" M (25 mm M x 25 mm M) Whip Hose
227677*	1" M x 1" M Whip Hose connected to Model #2276 1" F x 1" F Reconnectable Safe-T-Break®
581277*	1" M x 1" M Whip Hose connected to Model #5812 1" F x 1" F Non-Reconnectable Safe-T-Break®
2278	1" M x 1" M (25 mm M x 25 mm M) Whip Hose with Swivel Nut

Guards

MODEL NO.	DESCRIPTION
3098*	Safe-T-Break® Scuff Guard

Accessories, Maintenance, and Testing

Model No.	Description
7000	Safe-T-Break® Drain Cup
3813	Safe-T-Break® Demonstration Kit

Color Chart

COLOR SUFFIX	SUFFIX	COLOR	COLOR SUFFIX
Blue	-01	White	-06
Red	-02	Gold	-08
Green	-03	Silver	-09
Black	-04	BP Green	-16
Yellow	-05	Pink	-20

*Safe-T-Breaks® and Safe-T-Break® Scuff Guards are to be ordered with the corresponding guard color option added to the model number.

Example: If BLUE guards are desired, add guard color option -01 to the model number (4034-01).

For custom colors, a minimum order of 4,000 guards will be required.

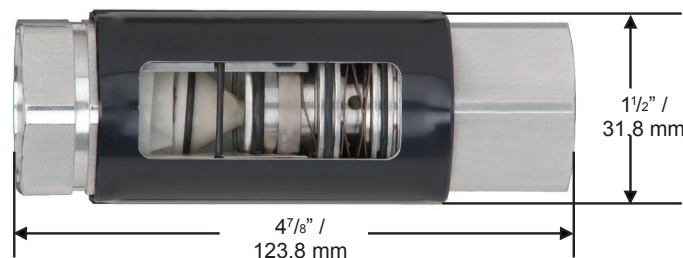
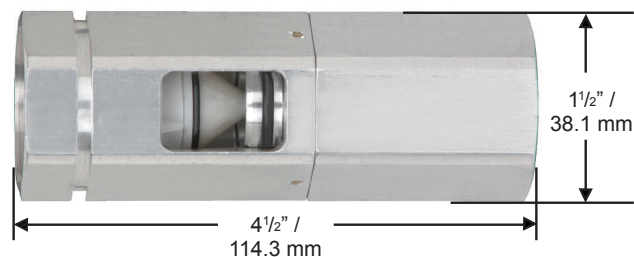

MADE IN THE U.S.A. 



Stop the flow of fluid on both sides of the separation.

Model #7219

- Non-reconnectable Safe-T-Break®
- Low profile design.
- Thread sealant not required with BSPP threads.
- 100% DEF compatible parts.
- Instant-closing, dual poppet check valve design.
- Maximum separation of 300 lbf / 1334.5 N.
- Comes standard with guard.

Model #8216

- Reconnectable Safe-T-Break®
- Maximum separation of 200 lbf / 889.6 N.
- 100% DEF compatible parts.
- Thread sealant not required with BSPP threads.
- Instant-closing, dual poppet check valve design.
- Comes standard with guard.

Safe-T-Breaks®

MODEL NO.	DESCRIPTION	SHIPPING WEIGHT LBS (KG)
7219	1" M x 1" M Stainless Steel Non-Reconnectable Safe-T-Break®	0.90 (.40)
8216	1" M x 1" M Stainless Steel Reconnectable Safe-T-Break®	0.94 (.43)

Construction

Body	Stainless Steel
Seals	Fluorocarbon
Inlet	1" / 25.4 mm BSPP

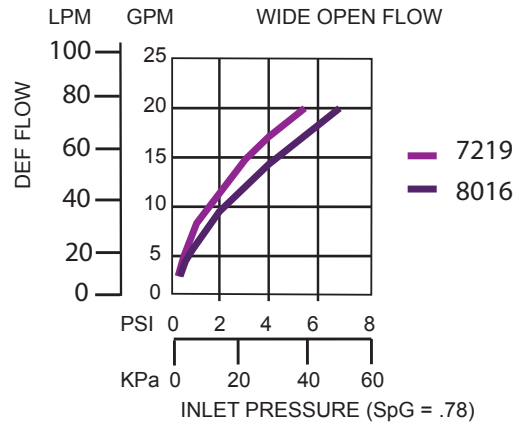

Model 7219



Model 8216



**Husky**

GENERAL FUELING PRODUCTS

DEF Safe-T-Break®

Stop the flow of fluid on both sides of the separation.

Dimensions and System Options

Guards

MODEL NO.	DESCRIPTION
7224	Black Scuff Guard
6503	Dispenser Scuff Guard

Accessories, Testing and Maintenance

MODEL NO.	DESCRIPTION
7523	1" BSPP Seal Kit Assembly

Model 7219

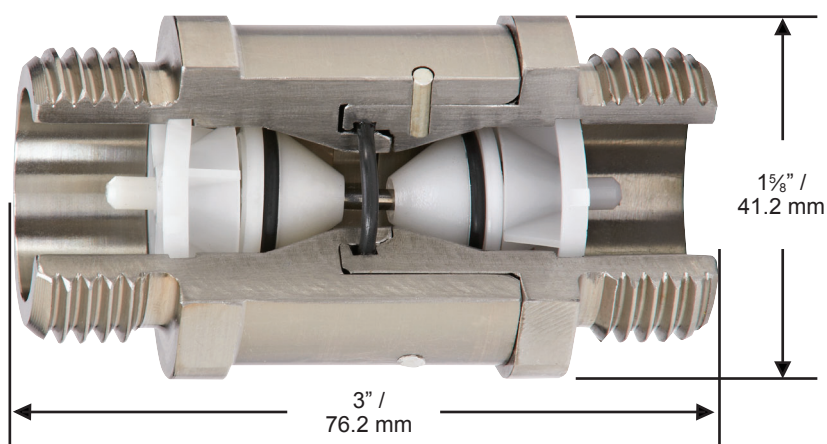

Model 8216

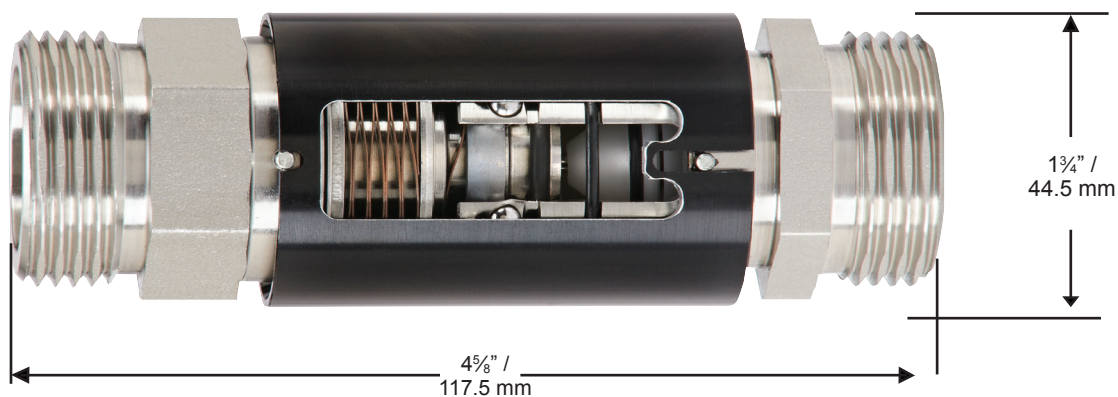

MADE IN THE U.S.A.



High Volume STB



All Husky Safe-T-Breaks® stop the flow of fuel on both sides of the separation and have passed the demanding UL test requirements on separations without leaking or failing.

Models 2276, 3076 and 3076A

- Retains UL listing after reconnection.
- Internal pressure balancing chamber prevents “line shock” nuisance separations.
- Separates at less than 200 lbf / 889.6 N which minimizes “backlash” force of separation, reducing damage to equipmen.

Model 5231

- Retains UL listing after reconnection.
- Uses the same internal pressure balancing chamber as Model #2276.
- Separates at less than 115 lbf / 511.5 N.

Model 5812 and 6914

- Light-weight, inexpensive and disposable.
- Same instant-closing dual poppet check valve design as Model 2276.
- Separates at less than 300 lbf / 1334.4 N.

Model 6301

- Internal Pressure Compensating Chamber (PCC) that prevents “line shock” nuisance separations.
- Same instant-closing dual poppet check valve as Model 2276.
- Separates at less than 225 lbf / 1000.8 N.

Reconnectable with NPTF

MODEL NO.	DESCRIPTION	SHIPPING WEIGHT LBS (KG)
2276*	1" F x 1" F Reconnectable Safe-T-Break®	.75 (.34)
5231*	1" F x 1" F Reconnectable Low-Pull Safe-T-Break®	.75 (.34)

Non-reconnectable with NPTF

MODEL NO.	DESCRIPTION	SHIPPING WEIGHT LBS (KG)
5812*	1" F x 1" F Non-Reconnectable Safe-T-Break®	.61 (.27)
6301*	1" F x 1" F PCC Non-Reconnectable Safe-T-Break®	.69 (.31)

Reconnectable with BSPP

MODEL NO.	DESCRIPTION	SHIPPING WEIGHT LBS (KG)
3076*	1" F x 1" F Reconnectable Safe-T-Break®	.75 (.34)
3076A*	1" F x 1" F Reconnectable Safe-T-Break® - Atex	.75 (.34)

Non-reconnectable with BSPP

MODEL NO.	DESCRIPTION	SHIPPING WEIGHT LBS (KG)
6914*	1" F x 1" F Non-Reconnectable Safe-T-Break®	.61 (.27)

*See page 2 for guard color options



Model 2276



Model 5812

Construction

Reconnectable Safe-T-Breaks®

Body	Aluminum
Seals	Fluorocarbon
Springs	Stainless Steel
Stainless steel load and latch spring reverse mechanism	
Hardened stainless steel latch ring and balls	

Non-Reconnectable Safe-T-Breaks®

Body	Zinc Alloys and Aluminum
Seals	Fluorocarbon

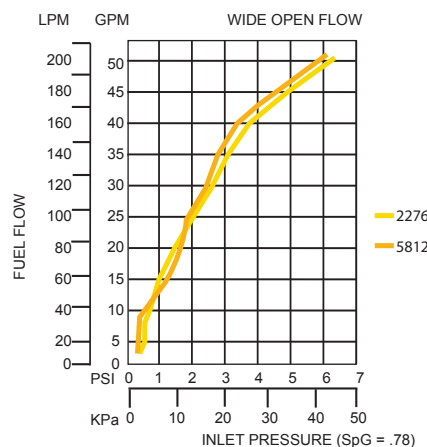



High Volume **STB**

All Husky Safe-T-Breaks® stop the flow of fuel on both sides of the separation and have passed the demanding UL test requirements on separations without leaking or failing.

Dimensions and System Options

Whip Hoses

MODEL NO.	DESCRIPTION
2277	1" M x 1" M (25 mm M x 25 mm M) Whip Hose
227677*	1" M x 1" M Whip Hose connected to Model #2276 1" F x 1" F Reconnectable Safe-T-Break®
581277*	1" M x 1" M Whip Hose connected to Model #5812 1" F x 1" F Non-Reconnectable Safe-T-Break®
2278	1" M x 1" M (25 mm M x 25 mm M) Whip Hose with Swivel Nut

Guards

MODEL NO.	DESCRIPTION
3098*	Safe-T-Break® Scuff Guard

Accessories, Maintenance, and Testing

Model No.	Description
7000	Safe-T-Break® Drain Cup
3813	Safe-T-Break® Demonstration Kit

Color Chart

COLOR SUFFIX	SUFFIX	COLOR	COLOR SUFFIX
Blue	-01	White	-06
Red	-02	Gold	-08
Green	-03	Silver	-09
Black	-04	BP Green	-16
Yellow	-05	Pink	-20

*Safe-T-Breaks® and Safe-T-Break® Scuff Guards are to be ordered with the corresponding guard color option added to the model number.

Example: If BLUE guards are desired, add guard color option -01 to the model number (4034-01).

For custom colors, a minimum order of 4,000 guards will be required.

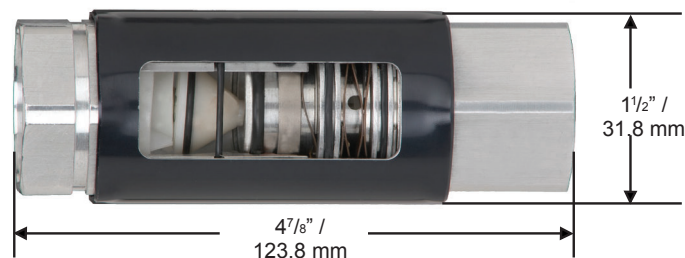
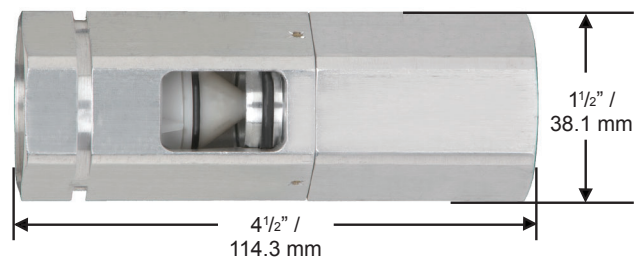

MADE IN THE U.S.A.

Balance Vapor **STB**



All Husky Safe-T-Breaks® stop the flow of fuel on both sides of the separation and have passed the demanding UL test requirements on separations without leaking or failing.

Model 3360VR

- Reconnectable Safe-T-Break® for balance vapor recovery systems - coaxial hoses with fuel on the “inside”, vapor return on the “outside”.
- Unique in-line latching mechanism requires less force to reconnect Safe-T-Break® after a separation.
- Unique vapor valve stops vapors from escaping after a drive away.
- Built-in vapor valve stops vapors from escaping after separation.
- Separates at less than 200 lbf / 889.6 N to minimize backlash damage.
- Patented wave spring design minimizes nuisance breaks.

Model 5900

- Non-reconnectable Safe-T-Break® for balance vapor recovery systems - coaxial hoses with fuel on the “inside”, vapor return on the “outside”.
- Internal pressure compensating chamber isolates shear pin from line shock preventing nuisance breaks.
- Separates at less than 250 lbf / 1112.1 N to minimize backlash damage.
- Same built-in vapor valve as Model 3360VR.

Reconnectable

MODEL NO.	DESCRIPTION	SHIPPING WEIGHT LBS (KG)
3360VR*	Reconnectable Safe-T-Break®	1.3 (.5)

Non-reconnectable

MODEL NO.	DESCRIPTION	SHIPPING WEIGHT LBS (KG)
5900*	Non-Reconnectable Safe-T-Break®	1.2 (.5)

Construction

Body	Aluminum
Seals	Fluorocarbon
Springs	Stainless Steel
Threads	1 7/8" x 12

Stainless steel load and latch spring reverse mechanism.
Hardened stainless steel latch ring and balls



Model 3600VR



Model 5900

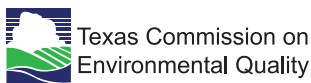
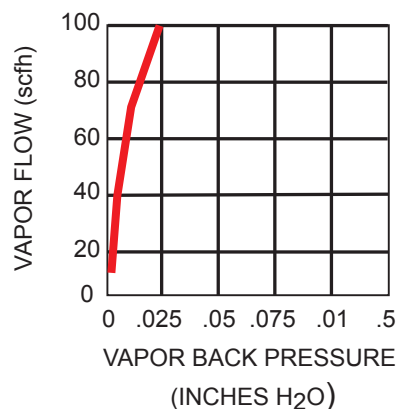



Balance Vapor **STB**

All Husky Safe-T-Breaks® stop the flow of fuel on both sides of the separation and have passed the demanding UL test requirements on separations without leaking or failing.

Dimensions and System Options

Whip Hoses

MODEL NO.	DESCRIPTION
2715	10" / 254 mm Coaxial Whip Hose
3360VR*-333	Reconnectable Safe-T-Break® connected to Model #2715 Coaxial Whip Hose

Guards

MODEL NO.	DESCRIPTION
3990*	Scuff Guard for 3360VR Safe-T-Break®
5895*	Scuff Guard for 5900 Safe-T-Break®

Pressure/Vacuum Vents

MODEL NO.	DESCRIPTION
7000	Safe-T-Break® Drain Cup

Color Chart

COLOR	SUFFIX	COLOR	SUFFIX
Blue	-01	White	-06
Red	-02	Gold	-08
Green	-03	Silver	-09
Black	-04	BP Green	-16
Yellow	-05	Pink	-20

*Safe-T-Breaks® and Safe-T-Break® Scuff Guards are to be ordered with the corresponding guard color option added to the model number.

Example: If BLUE guards are desired, add guard color option -01 to the model number (4034-01).

For custom colors, a minimum order of 4,000 guards will be required.

Model 3360VR

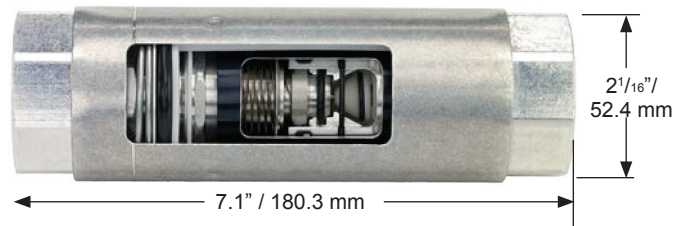

Model 5900

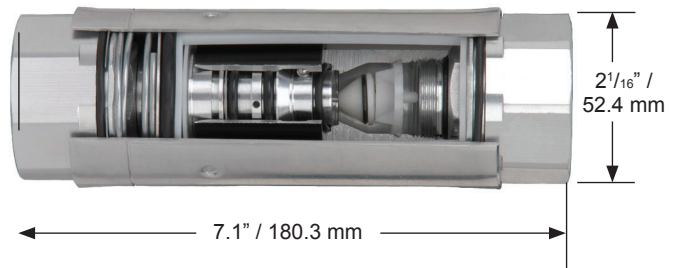

MADE IN THE U.S.A.



All Husky Safe-T-Breaks® stop the flow of fuel on both sides of the separation and have passed the demanding UL test requirements on separations without leaking or failing.

Model 4034

- Reconnectable Safe-T-Break® for the vapor assist systems: coaxial hoses with fuel “outside” hose, vapor return “inside” hose.
- Meets the reconnect endurance test of the UL Standard 567 Ninth Edition.
- Unique vapor valve stops vapors from escaping after a drive away.
- Separates at less than 200 lbf / 889.6 N to minimize backlash damage.
- Unique pre-loaded shock absorbing wave spring minimizes nuisance breaks.

Model 6560

- Reconnectable Safe-T-Break® designed for the Veeder-Root® 900301 and VST Enviro-Loc™ primary hose with ORVR valve.
- Same style and design as Model 4034 including the same fuel / vapor paths and separation force.

Model 6210 & 5134A

- Non-reconnectable Safe-T-Breaks® in the same style and design as Model 4034, including the same fuel / vapor paths and separation force.

Reconnectable

MODEL NO.	DESCRIPTION	SHIPPING WEIGHT LBS (KG)
4034*	Reconnectable Safe-T-Break®	3.9 (1.7)
4034A*	Reconnectable Safe-T-Break® 1.0 (.45) - Atex	3.9 (1.7)
6560*	Reconnectable Safe-T-Break® 1.0 (.45) for ORVR	4.2 (1.9)

Non-reconnectable

MODEL NO.	DESCRIPTION	SHIPPING WEIGHT LBS (KG)
6210*	New with Three Notch Hold Open Clip	4.0 (1.8)
5134A*	New without Hold Open Clip	4.0 (1.8)

*See page 2 for guard color options

Construction

Body	Aluminum
Seals	Fluorocarbon
Springs	Fiber Reinforced Teflon
Threads	4034, 4034A, 5134A and 6210 = M34 x 1.5 6560 = 1 1/4" - 18

Stainless steel load and latch spring reverse mechanism.
Hardened stainless steel latch ring and balls.



Model 4034



Model 6210

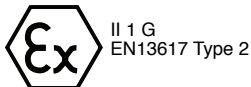
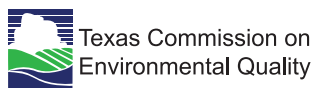
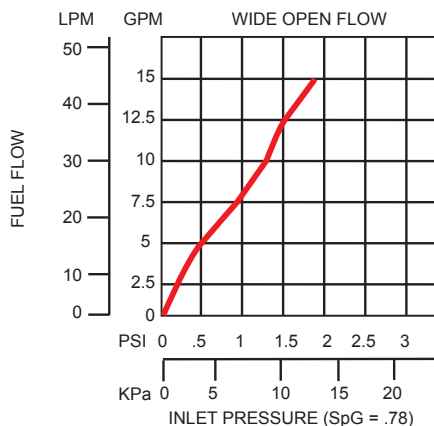
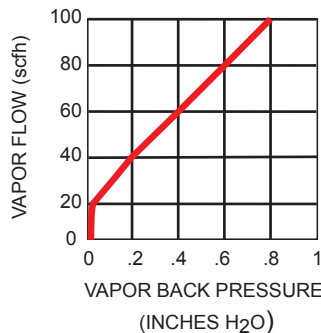



Vacuum Assist **STB**

All Husky Safe-T-Breaks® stop the flow of fuel on both sides of the separation and have passed the demanding UL test requirements on separations without leaking or failing.

Dimensions and System Options

Safe-T-Breaks®

MODEL NO.	DESCRIPTION
3360VR	Reconnectable Safe-T-Break®
5900	Non-Reconnectable Safe-T-Break®

Spouts

MODEL NO.	DESCRIPTION
5800-01	Complete Unleaded Assembly Kit - Short
5802-01	Unleaded Spout - Short
5900-01	Complete Unleaded Assembly Kit - Long
5902-01	Unleaded Spout - Long

Pressure/Vacuum Vents

MODEL NO.	DESCRIPTION
4620	2" Slip-On Pressure Vacuum Vent
4885	2" Thread-On Pressure Vacuum Vent - NPTF
5885	2" Thread-On Pressure Vacuum Vent with internal screen - NP

Guards

Model No.	Description
3098*	Scuff Guard for 4034, 4034A, 5134A, 6210 & 6560 Safe-T-Breaks®

Color Chart

COLOR	SUFFIX	COLOR	SUFFIX
Blue	-01	White	-06
Red	-02	Gold	-08
Green	-03	Silver	-09
Black	-04	BP Green	-16
Yellow	-05	Pink	-20

*Safe-T-Breaks® and Safe-T-Break® Scuff Guards are to be ordered with the corresponding guard color option added to the model number.

Example: If BLUE guards are desired, add guard color option -01 to the model number (4034-01).

For custom colors, a minimum order of 4,000 guards will be required.

Model 4034 & 6560



Model 5134A & 6210

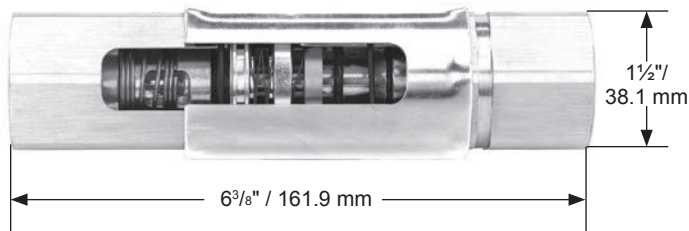

MADE IN THE U.S.A. 

E85 Safe-T-Breaks®



10-9

SAFE-T-BREAKS®

All Husky Safe-T-Breaks® stop the flow of fuel on both sides of the separation.

Husky Model 6360 Reconnectable Safe-T-Break®

- Compatible with unlead, diesel and all Ethanol blends through E100.
- Unusual interface between a pre-loaded spring and a single turn wave spring that enables valve to resist sudden pressure build-up in the hose resulting in nuisance separations.
- Retains the UL listing after being reconnected.
- Unit separates at less than 200 lbf / 889.6 N which minimizes “backlash” force of separation, reducing damage to equipment.

Husky Model 6273 Standard Non-Reconnectable Safe-T-Break®

- Compatible with unlead, diesel and all Ethanol blends through E100.
- Unit is lightweight, inexpensive and disposable.
- Features same instant closing dual poppet check valve design as Model #6360.
- Maximum separation of 300 lbf / 1334.5 N.

E85 Safe-T-Breaks®

MODEL NO.	DESCRIPTION	SHIPPING WEIGHT LBS (KG)
6360*	¾" F x ¾" F Reconnectable Safe-T-Break®	.58 (.26)
6273	¾" F x ¾" F Standard Non-Reconnectable Safe-T-Break®	.30 (.13)

Construction

Body	Aluminum with Electroless Nickel Plating
Seals	Fluorocarbon
Springs	Stainless Steel
Threads	¾" / 19.1 mm NPTF
Stainless steel load and latch spring reverse mechanism (Model 6360).	
Hardened stainless steel latch ring and ball (Model 6360)	



Model 6360



Model 6273

6360

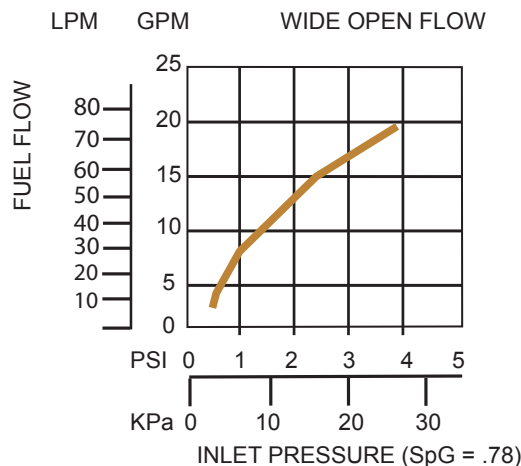

6273

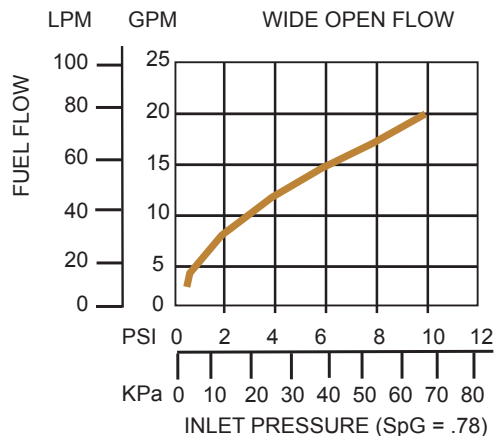



Husky

GENERAL FUELING PRODUCTS

E85 Safe-T-Breaks®

All Husky Safe-T-Breaks® stop the flow of fuel on both sides of the separation.

Dimensions and System Options

Guards

MODEL NO.	DESCRIPTION
6303*	Yellow Scuff Guard

Whip Hoses

MODEL NO.	DESCRIPTION
2274	3/4" / 19.1 mm M x 3/4" / 19.1 mm M Standard Whip Hose
2275	3/4" / 19.1 mm M x 3/4" / 19.1 mm M Standard Whip Hose with Swivel Nut

Accessories, Testing and Maintenance

MODEL NO.	DESCRIPTION
7000	Safe-T-Break® Drain Cup
3813	Safe-T-Break® Demonstration Kit

Model 6273



Model 6360

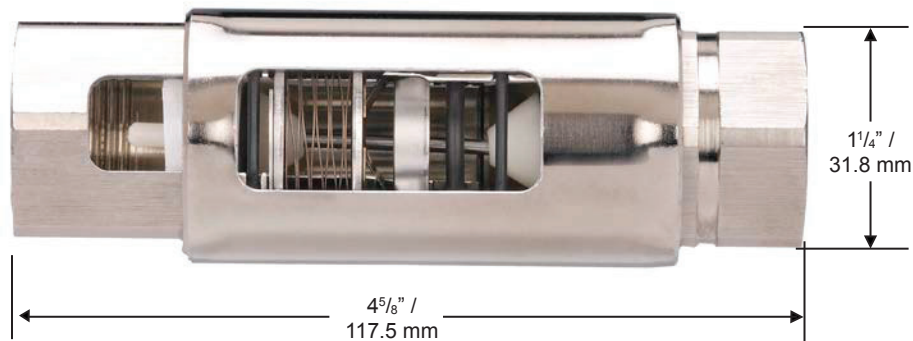

MADE IN THE U.S.A.



Husky

GENERAL FUELING PRODUCTS

Swivel/Safe-T-Break[®] Combos



Husky Model 6310 Swivel Safe-T-Break® combination for standard fueling applications.

- Multi-plane, full 360° spherical rotation for easy movement of nozzle.
- Swivel Sync® feature to prevent separation failure in the 90° position.
- Safe-T-Break® is reconnectable and retains UL listing after reconnecting.
- Dual check valves stops fuel in both directions.
- Separates at less than 225 lbf / 1000.9 N which minimizes backlash force of separations, reducing damage to equipment.
- Wave spring helps reduce nuisance breaks due to water hammer.
- Dynamic seals have double o-ring construction for long life and low temperature performance.
- Compatible with fuels containing up to 15% alcohol.
- Compact and light weight for easy handling.
- Easier to reconnect when installed at the nozzle.
- Eliminates the need for a whip hose.

Swivel/Safe-T-Break® Combination

MODEL NO.	DESCRIPTION	SHIPPING WEIGHT LBS (KG)
6310	¾" M x ¾" F Multi-Plane Swivel Reconnectable Safe-T-Break®	.90 (.40)

Construction

Body	Aluminum, Zinc Alloy
Seals	Fluorosilicone, Fluorocarbon
Springs	Stainless Steel
Threads	¾" / 19.1 mm NPTF

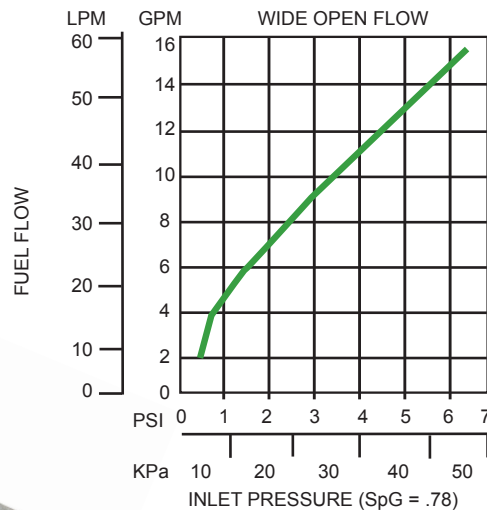

**Husky**

GENERAL FUELING PRODUCTS

Swivel/STB Standard

Husky Model 6310 Swivel Safe-T-Break® Combination for standard fueling applications.

Dimensions

Guards

MODEL NO.	DESCRIPTION
6534	Scuff Guard for Safe-T-Break®

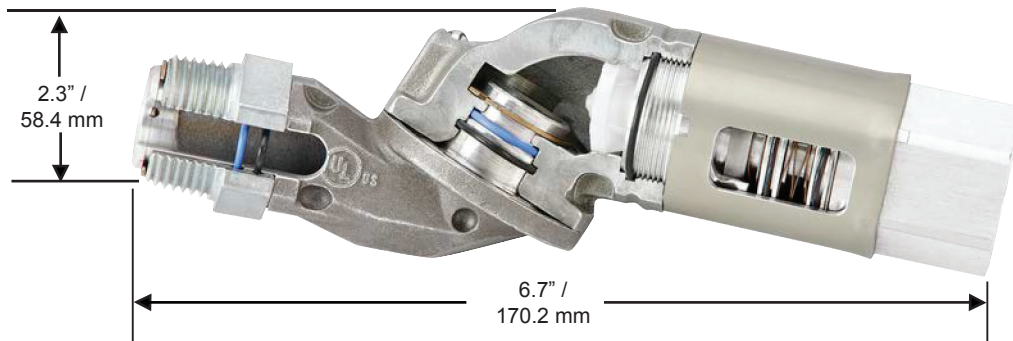

MADE IN THE U.S.A. 



Husky Model 5969 Swivel Safe-T-Break® Combination for truck and high volume fueling.

- Multi-plane, full 360° spherical rotation for easy movement of nozzle.
- Swivel Sync® feature to prevent separation failure in the 90° position.
- High strength step shoulder bearing diameters and impact absorbing stops.
- Dynamic seals have double o-ring construction for long life and low temperature performance.
- Separates at less than 225 lbf / 1000.9 N which minimizes backlash force of separations, reducing damage to equipment.
- Safe-T-Break® is reconnectable and retains UL listing after reconnecting.
- Dual check valves stop fuel in both directions.
- Internal pressure balancing chamber prevents “line shock” nuisance separations.
- Compatible with fuels containing up to 15% alcohol.
- Compact and light weight for easy handling.
- Easier to reconnect when installed at the nozzle.
- Eliminates the need for a whip hose

Swivel/Safe-T-Break® Combination

MODEL NO.	DESCRIPTION	SHIPPING WEIGHT LBS (KG)
5969	1" M x 1" F Multi-Plane Swivel Reconnectable Safe-T-Break®	1.5 (0.7)

Construction

Body	Aluminum, Zinc Alloy
Seals	Fluorocarbon
Springs	Stainless Steel
Threads	1" NPTF

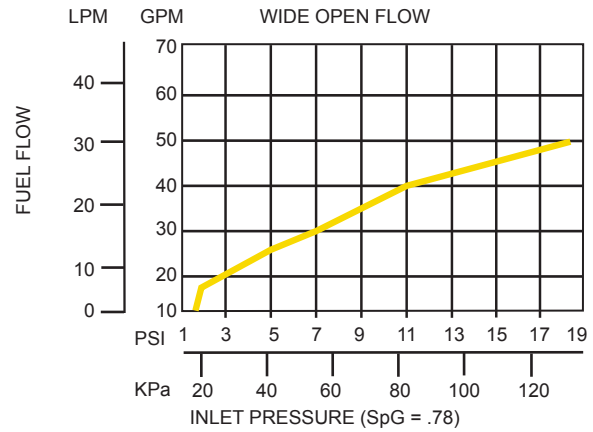

**Husky**

GENERAL FUELING PRODUCTS

Swivel/STB High Volume

Husky Model 5969 Swivel Safe-T-Break® Combination for truck and high volume fueling.

Dimensions and System Options

Guards

MODEL NO.	DESCRIPTION
6534	Scuff Guard for Safe-T-Break®

Accessories, Testing and Maintenance

MODEL NO.	DESCRIPTION
7000	Safe-T-Break® Drain Cup

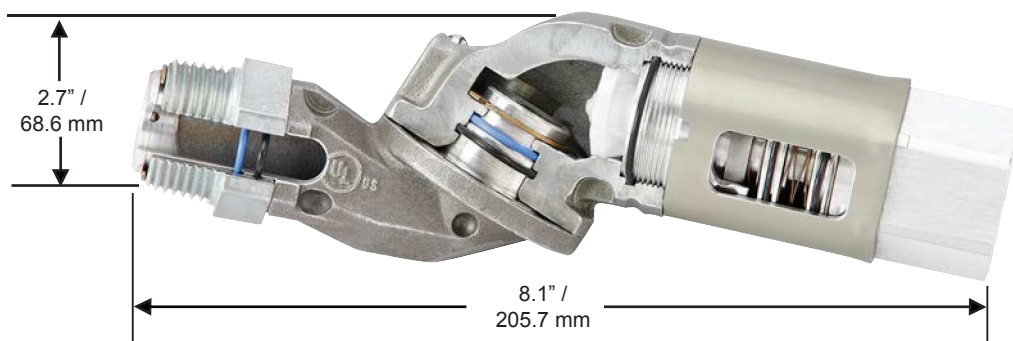

MADE IN THE U.S.A.





Husky

GENERAL FUELING PRODUCTS

Guards

HUSKY Guards



For nozzles and Safe-T-Breaks.®

Nozzle Guards

- Nozzle Guards, Nozzle Regards, Waffle Splash Guards and Safe-T-Break® Guards are to be ordered with the corresponding color option added to the model number.
- Custom colors are available for all Nozzle Guards, Nozzle Regards, Waffle Splash Guards and Safe-T-Break® Guards.
- The Safety / Warning logo will be printed on all Nozzle Guards and Nozzle Regards.
- The E85 logo is available on all Nozzle Guards, Nozzle Regards and Safe-T-Break® Guards upon request.
- A customized logo can be printed on any Nozzle Guard or Nozzle Reguard upon request

Safe-T-Break® Guards

- Protects dispenser from damage caused by the Safe-T-Break® and whip hose.
- Protects the Safe-T-Break® against corrosion due to environmental exposure.
- Enhanced protection of the Safe-T-Break® during separations.
- Provides a clean / more streamline appearance.
- Available in multiple colors to coordinate with the nozzle guards.
- Available with E85 logo.



Full Grip Nozzle Guards

MODEL NO.	DESCRIPTION	SHIPPING WEIGHT LBS (KG)
0554	1A, 1GS, 1HS Nozzles	
4145	X, XS, XFS Nozzles	
4740	VIII, VIIS Nozzles	
5950	V, VLX Nozzles	
5170	V3 Nozzles	
6483	Safe-T-Squeeze® Nozzles	
6951	V34 Nozzles	

Full Grip Nozzle Regards (includes zip tie)

MODEL NO.	DESCRIPTION	SHIPPING WEIGHT LBS (KG)
1804	1A, 1GS, 1HS Nozzles	
1806	X, XS, XFS Nozzles	
5516	VIII, VIIS Nozzles	
4190	V, VLX Nozzles	
4231	V34 Nozzles	
5169	V3 Nozzles	

Nozzle Guard Packages

MODEL NO.	DESCRIPTION	SHIPPING WEIGHT LBS (KG)
0099	1A, 1HS Nozzle Protection Package (includes #0554 Full Grip Nozzle Guard and #1808 Waffle Splash Guard)	
1506	X, XS Nozzle Protection Package (includes #4145 Full Grip Nozzle Guard and #1808 Waffle Splash Guard)	
1809	X, XS Nozzle Reguard Package (includes #1806 Full Grip Reguard, Zip Tie and #1808 Waffle Splash Guard)	
1811	1A, 1HS Nozzle Reguard Package (includes #1804 Full Grip Reguard, Zip Tie and #1808 Waffle Splash Guard)	

Waffle Splash Guards

MODEL NO.	DESCRIPTION	SHIPPING WEIGHT LBS (KG)
1807	Waffle Splash Guard (small hole)	
1808	X, XS, 1A, 1HS, VIII, VIIS Nozzles	
6955	V3 Nozzles	

Safe-T-Break® Guards

MODEL NO.	DESCRIPTION	SHIPPING WEIGHT LBS (KG)
3096	#3360, 6130, and 5230 Safe-T-Breaks®	
3098	#2276, 4034, 5134, 6210, 6301, and 6560 Safe-T-Breaks®	
3990	#3360VR Safe-T-Break®	
6534	#6310 Swivel Safe-T-Break® Combo	
6503	2 piece Safe-T-Break® Dispenser Guard	
6570	2 piece Safe-T-Break® Dispenser Guard with E85 logo	

Mate Nozzle Guards

MODEL NO.	DESCRIPTION	SHIPPING WEIGHT LBS (KG)
3795	X, XS, XFS Nozzles	
3376	Fluted Handle Cover	

Easy-On Guard Package

MODEL NO.	DESCRIPTION	SHIPPING WEIGHT LBS (KG)
3440	X, XS, XFS Nozzles (includes #3795 Mate Nozzle Guard and #3376 Fluted Handle Cover)	



**Husky**

GENERAL FUELING PRODUCTS

HUSKY Guards

For nozzles and Safe-T-Breaks®

Color Chart

COLOR	SUFFIX	COLOR	SUFFIX
Blue	-01	White	-06
Red	-02	Gold	-08
Green	-03	Silver	-09
Black	-04	BP Green	-16
Yellow	-05	Pink	-20

*Safe-T-Breaks® and Safe-T-Break® Scuff Guards are to be ordered with the corresponding guard color option added to the model number.

Example: If BLUE guards are desired, add guard color option -01 to the model number (4034-01).

For custom colors, a minimum order of 4,000 guards will be required.



MADE IN THE U.S.A.

POPD Guards



Point of purchase display nozzle guards.

- Allows additional advertising at the point of fuel purchases.
- Unique angled design for easy readability both hanging in dispenser and while fueling.
- Guards come standard with clear cover to protect the advertisement.
- Clear cover contains UV stabilizer for durability and to prevent discoloring.
- Built-in to the nozzle guard for easy installation.



Full Grip Nozzle Guards

MODEL NO.	DESCRIPTION
6665	X, XS®, XFS Nozzles
6655	1A, 1HS, 1GS Nozzles
7352	VIII, VIIS Nozzles
6650	V, VLX Nozzles
6660	V34 Nozzles
7175	11A Nozzles
7180	11B Nozzles
8182	V, VLX, Nozzles
8183	1A, 1GS, 1HS, Nozzles
8184	V34 Nozzle
8185	X, XS, XFS Nozzles
8186	VIII, VIIS, Nozzles
8187	11A Nozzles
8188	11B Nozzles

Full Grip Nozzle Reguards

MODEL NO.	DESCRIPTION
7205	X, XS®, XFS Nozzles
7210	1A, 1HS, 1GS Nozzles
7215	V, VLX Nozzles
7220	V34 Nozzles
7225	11A Nozzles
7230	11B Nozzles
8194	VIII, VIIS Nozzles
8189	V, VLX Nozzles
8190	1A, 1GS, 1HS Nozzles
8191	V34 Nozzle
8192	X, XS, XFS Nozzles
8193	VIII, VIIS Nozzles
8195	11A Nozzles
8196	11B Nozzles

Clear Cover

MODEL NO.	DESCRIPTION
6628	POPD S Clear Cover
8181	POPD H Clear Cover

EZ Guards

MODEL NO.	DESCRIPTION
8179	1A, 1GS, 1HS Nozzles
8175	X, XS, XFS Nozzles
8177	VIII, VIIS Nozzles
7990	11A Nozzles
7992	11B Nozzles
8180	1A, 1GS, 1 HS Nozzles
8176	X, XS, XFS Nozzles
8178	VIII, VIIS Nozzles
7991	11A Nozzles
7993	11B Nozzles



**Husky**

GENERAL FUELING PRODUCTS

POPD Guards

Point of purchase display nozzle guards.

System Options

Matte Guards

MODEL NO.	DESCRIPTION
8169	1A, 1GS, 1HS Nozzles
8165	X, XS, XFS Nozzles
8167	VIII, VIIS Nozzles
8171	11A Nozzles
8173	11B Nozzles
8170	1A, 1GS, 1HS Nozzles
8166	X, XS, XFS Nozzles
8168	VIII, VIIS Nozzles
8172	11A Nozzles
8174	11B Nozzles

Mate Nozzle Guard

MODEL NO.	DESCRIPTION
	X, XS®, XFS Nozzles
	1A, 1HS, 1GS, and DEF Nozzles

Black Handle Cover

MODEL NO.	DESCRIPTION
3376	X, XS®, XFS Nozzles
7376	1A, 1HS, 1GS and DEF Nozzles

Waffle Splash Guard

MODEL NO.	DESCRIPTION
1808	X, XS®, 1A, 1HS, VIII, VIIS Nozzles
1807	11A, 11B Nozzles

Color Chart

COLOR	SUFFIX	COLOR	SUFFIX
Blue	-01	White	-06
Red	-02	Gold	-08
Green	-03	Silver	-09
Black	-04	BP Green	-16
Yellow	-05	Pink	-20

*Safe-T-Breaks® and Safe-T-Break® Scuff Guards are to be ordered with the corresponding guard color option added to the model number.

Example: If BLUE guards are desired, add guard color option -01 to the model number (4034-01).

For custom colors, a minimum order of 4,000 guards will be required.



MADE IN THE U.S.A.



Husky

GENERAL FUELING PRODUCTS

Spouts

X, XS Spouts



Spout assemblies.

- Stainless Steel Spout Bushing (optional on LDD).
- *Streamshaper*[™] (optional on LDD).
- Keeps spout tip round.
- Reduces turbulence for straighter fuel flow and less splashback spillage.

Unlead Spout Assemblies

MODEL NO.	DESCRIPTION	SHIPPING WEIGHT LBS (KG)
1473	X, XS, 1A, 1GS Spout Assembly with <i>Streamshaper</i> [™]	.3 (.14)
8684	X, XS, 1A, 1GS MTBE Spout Assembly with <i>Streamshaper</i> [™]	.3 (.14)
10432	X, XS, 1A, 1GS Long Spout Assembly with <i>Streamshaper</i> [™]	.4 (.18)

Light Duty Diesel Spout Assemblies

MODEL NO.	DESCRIPTION	SHIPPING WEIGHT LBS (KG)
1471	X, XS, 1A, 1GS Spout Assembly	.4 (.18)
8862	X, XS, 1A, 1GS Spout Assembly with <i>Streamshaper</i> [™]	.4 (.18)



Unlead Spout Assembly



Light-Duty Diesel Spout Assembly



Spout Assemblies.

Dimensions

Unlead Spouts

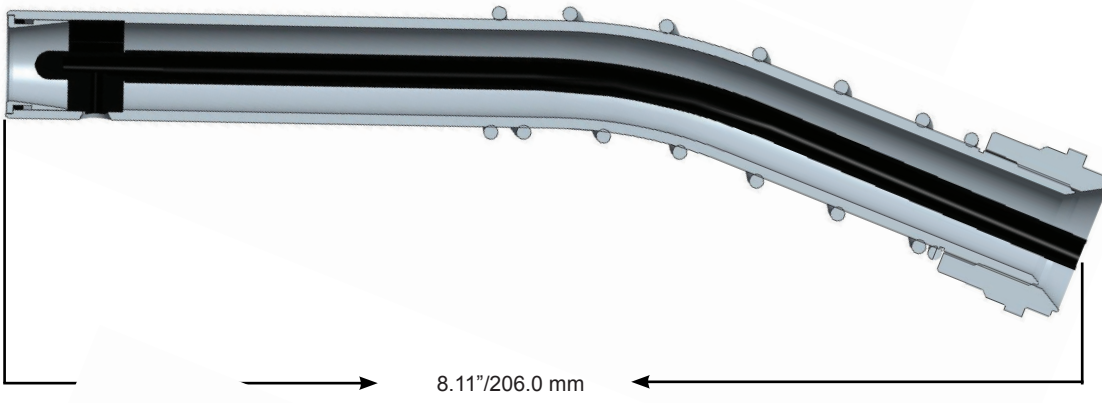
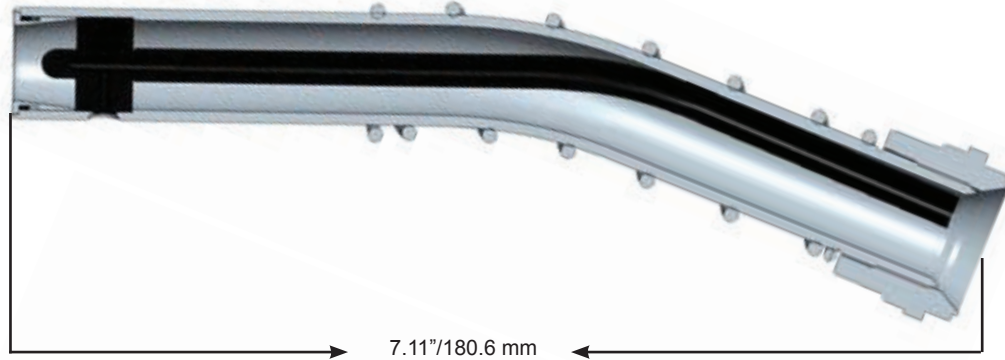

Light Duty Diesel Spout

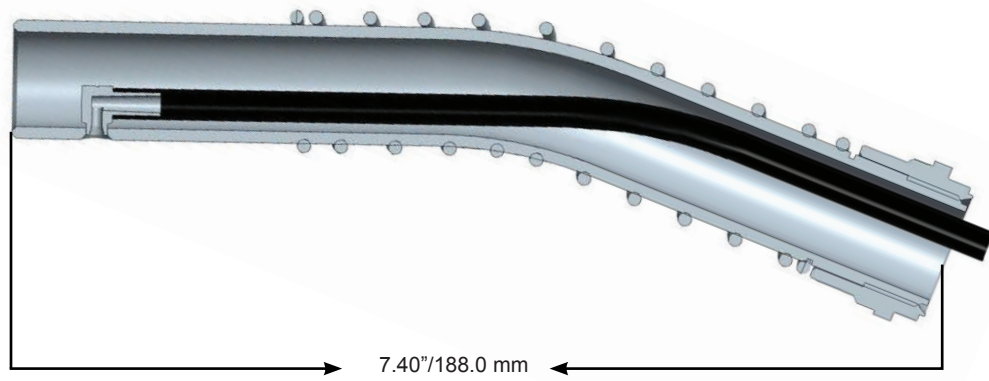

Safe-T-Squeeze Spouts



13-2

SPOUT ASSEMBLIES

Spout assemblies.

- Stainless Steel Spout Bushing
- *Streamshaper*™
- Keeps spout tip round
- Reduces turbulence for straighter fuel flow and less splashback spillage

HIGH FLOW/HIGH VOLUME SPOUT ASSEMBLIES

MODEL NO.	DESCRIPTION	SHIPPING WEIGHT LBS (KG)
5934	Safe-T-Squeeze® Bellows Clamp	.1 (.05)
6648	Safe-T-Squeeze® Complete Spout Assy Kit (Includes #6651 Spout Kit, #6649 Complete Bellows Kit and #5934 Clamp)	.5 (.23)
6649	Safe-T-Squeeze® Complete Bellows Assy Kit (Includes #5934 Clamp)	.2 (.09)
6651	Safe-T-Squeeze® Spout Kit W/Streamshaper™ (Includes #5920 Slider Clamp, #5934 Clamp and #5695 Push Pin)	.5 (.23)
7380	Safe-T-Squeeze® Complete Dripless Spout Assy Kit W Streamshaper™ (Includes #5934 Clamp and #5695 Push Pin)	.5 (.23)
7385	Safe-T-Squeeze® Dripless Spout Assy Kit w/Streamshaper™ (Includes #5920 Slider Clamp, #5934 Clamp and #5695 Push Pin)	.5 (.23)



**Husky**

GENERAL FUELING PRODUCTS

Safe-T-Squeeze Spouts

Spout Assemblies.

Dimensions

High Flow/High Volume Spouts

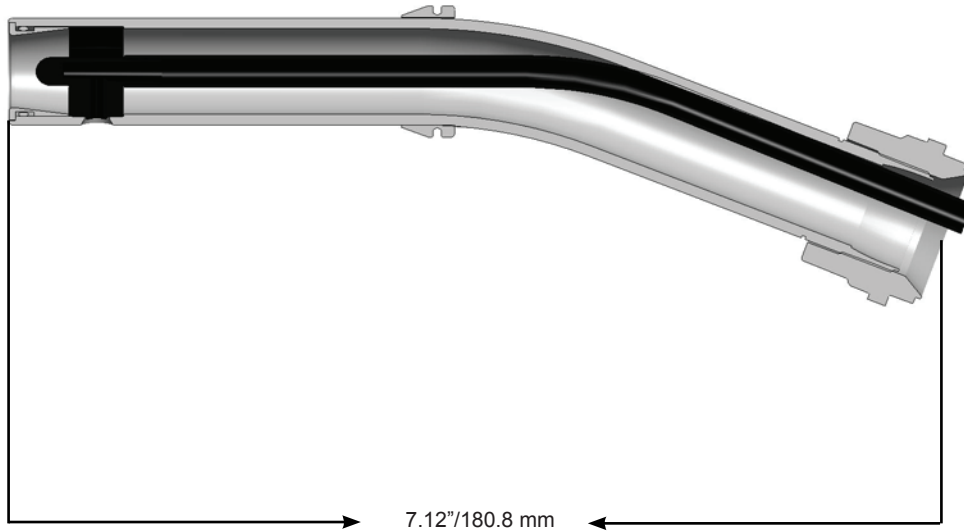

MADE IN THE U.S.A. 

1GS Spouts



Spout assemblies.

- Stainless Steel Spout Bushing (optional on LDD).
- *Streamshaper*[™] (optional on LDD).
- Keeps spout tip round.
- Reduces turbulence for straighter fuel flow and less splashback spillage.



Unlead Spout Assemblies

MODEL NO.	DESCRIPTION	SHIPPING WEIGHT LBS (KG)
1473	X, XS, 1A, 1GS Spout Assembly with <i>Streamshaper</i> [™]	.3 (.14)
3356	XFS Spout Assy with Hanging Hook and <i>Streamshaper</i> [™]	.5 (.23)
8684	X, XS, 1A, 1GS MTBE Spout Assembly with <i>Streamshaper</i> [™]	.3 (.14)
10432	X, XS, 1A, 1GS Long Spout Assembly with <i>Streamshaper</i> [™]	.4 (.18)

Light Duty Diesel Spout Assemblies

MODEL NO.	DESCRIPTION	SHIPPING WEIGHT LBS (KG)
1471	X, XS, 1A, 1GS Spout Assembly	.4 (.18)
3358	XFS Spout Assembly with Hanging Hook	.6 (.27)
8862	X, XS, 1A, 1GS Spout Assembly with <i>Streamshaper</i> [™]	.4 (.18)

High Flow/High Volume Spout Assemblies

MODEL NO.	DESCRIPTION	SHIPPING WEIGHT LBS (KG)
5215	1HS, 1GS Spout Assembly	.4 (.18)



Spout assemblies.

Dimensions

Unlead Spouts

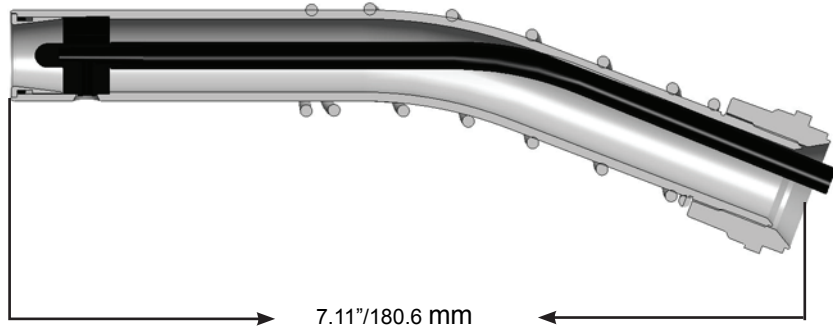

Light Duty Diesel Spout

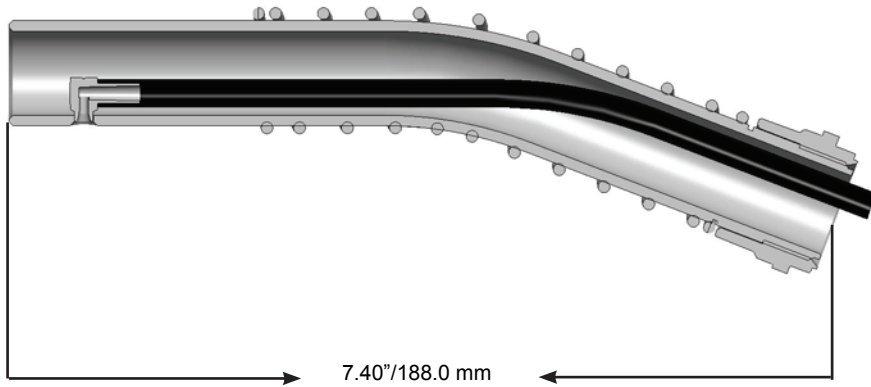

High Flow/High Volume Spout

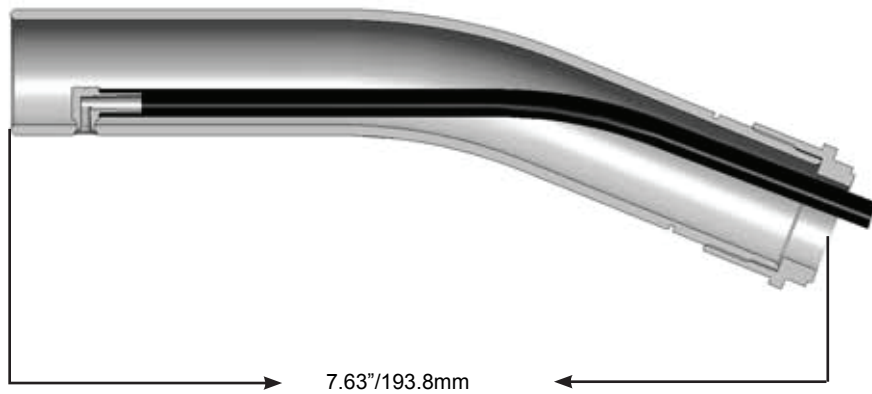

Spout assemblies.

Diesel Exhaust Spout Assemblies

MODEL NO.	DESCRIPTION	SHIPPING WEIGHT LBS (KG)
7360	Spout Assembly with Spout Ring and Flo-Stop™	.4 (.18)
7362	Spout Assembly with Flo-Stop™ and Accufuel™ Safety Feature	.4 (.18)
7364	Spout Assembly with Spout Ring, Flo-Stop™ And Accufuel™ Safety Feature	.4 (.18)



Spout Assemblies.

Dimensions

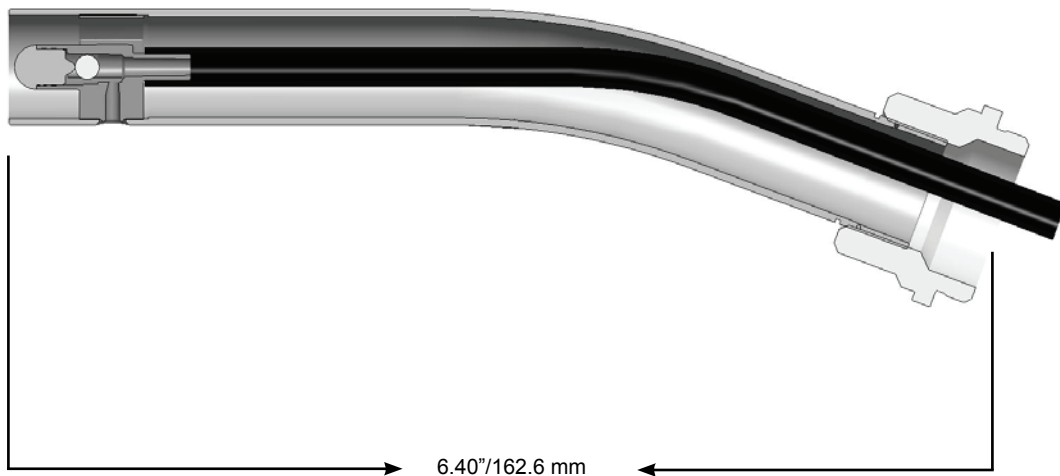
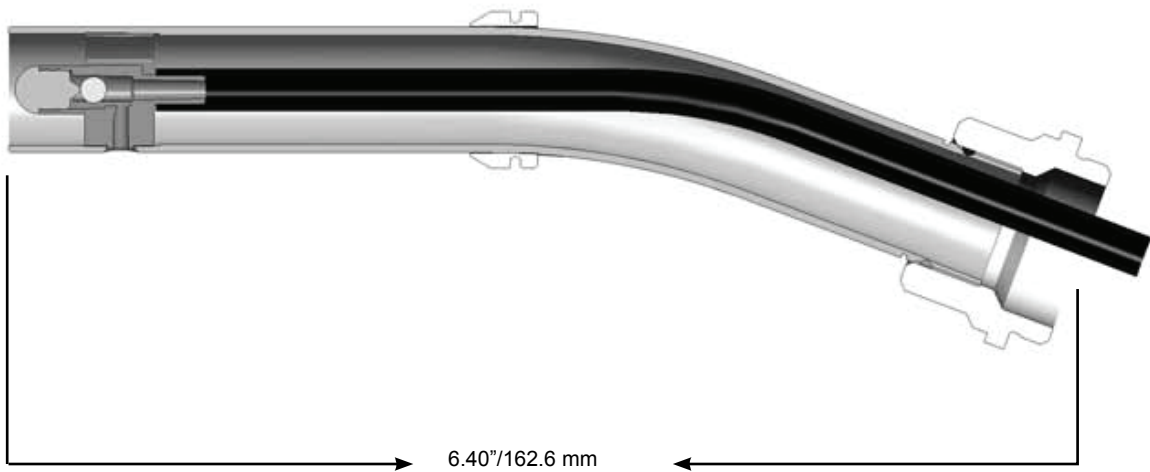

VIII, VIIS Spouts



Spout assemblies.

- Aluminum Spout Bushing.
- Flow stop device.
- Reduces rounding in of spout.
- Retains spout spring.
- Shuts off flow when spout is raised above horizontal.

High Flow/High Volume Spout Assemblies

MODEL NO.	DESCRIPTION	SHIPPING WEIGHT LBS (KG)
2279	VIII, VIIS Spout Assembly with Spout Bushing .9 (.41)	
3589	VIII, VIIS Long Spout Assembly without Spout Bushing	1.0 (.45)
4889	1690 High-Volume Spout Assembly without Shear Groove (USA)	.5 (.23)
5017	VIII, VIIS Spout Assembly without Spout Bushing .9 (.41)	
5042	1691 High-Volume Spout Assembly with Shear Groove (Canada)	.5 (.23)
5215	1HS, 1GS Spout Assembly	.4 (.18)
7218	VIII, VIIS Long Spout Assembly with Spout Bushing	1.0 (.45)



Spout assemblies.

Dimensions

High Flow/High Volume Spouts

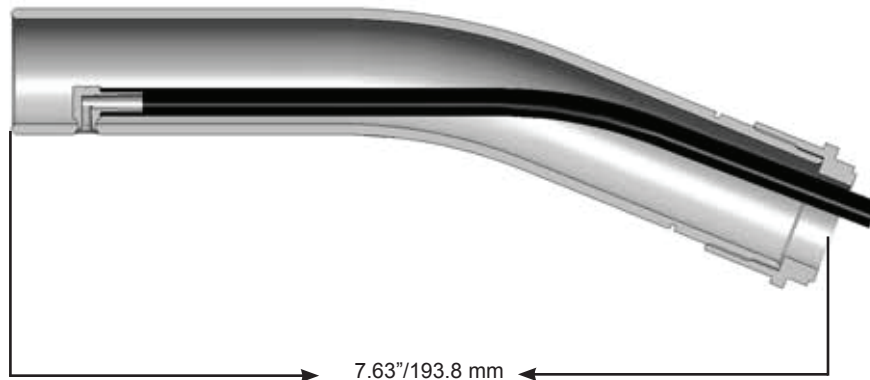
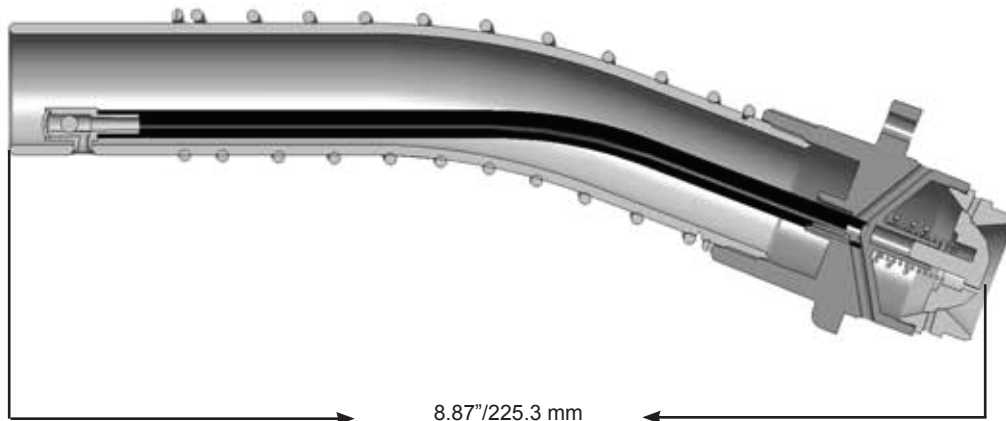
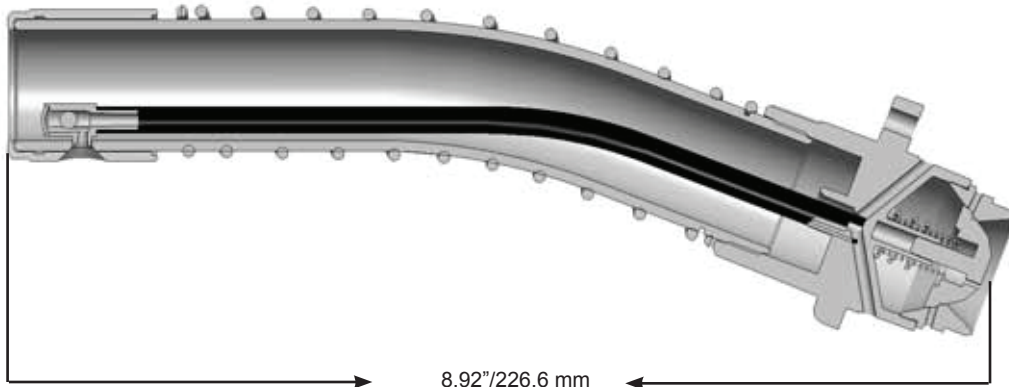

V, V3, V34 Spouts



Husky

GENERAL FUELING PRODUCTS

13-6

SPOUT ASSEMBLIES

Spout assemblies.

- Stainless steel spout bushing.
- *Streamshaper*[™] reduces turbulence for straighter fuel flow and less splash back spillage.
- Keeps spout tip round.



V3 Spout Kit



V34 Spout Kit

Vacuum Assist Vapor Recovery Unlead Spout Assemblies

MODEL NO.	DESCRIPTION	SHIPPING WEIGHT LBS (KG)
4000	V34 Vapor Splash Guard (VSG) (Includes #4039 Clamp)	.1 (.05)
4039	VSG Single Use Clamp	.1 (.05)
6289	V3 Spout Assy Kit (Includes #6389 Spout Assembly and #6955 Waffle Splash Guard)	.3 (.14)
6291	V34 Spout Assy Kit (Includes #4000 VSG and #6391 Spout Assembly)	.3 (.14)
6389	V3 Spout Assembly (without Waffle Splash Guard)	.2 (.09)
6391	V34 Spout Assembly W/ <i>Streamshaper</i> [™]	.3 (.14)
6656	V34-6536 VSG (Includes #4039 Clamp)	.1 (.05)
6663	V34-6536 Spout Assembly Kit (Includes #6391 Spout Assembly and #6656 VSG)	.3 (.14)
8411	V34i Spout Assembly Kit with <i>Streamshaper</i> [™] (Includes #3877 O-Ring and #6511 Set Screw)	.2 (.09)
8642	V34-6200 Coaxial Spout Assembly Kit (Includes #9968 Spout Assembly and #4000 VSG)	.3 (.14)
9968	V34-6200 Coaxial Spout Assembly	.2 (.09)

Vacuum Assist Vapor Recovery Light Duty Diesel Spout Assemblies

MODEL NO.	DESCRIPTION	SHIPPING WEIGHT LBS (KG)
6261	V34C Spout Assembly Kit (Includes #4000 Vsg)	.4 (.18)
6361	V34 Spout Assembly Kit (Includes #4039 Clamp)	.3 (.14)

Balance Vapor Recovery Unlead Spout Assemblies

MODEL NO.	DESCRIPTION	SHIPPING WEIGHT LBS (KG)
2879	V, VLX Bellow Clamp	.1 (.05)
5801	V Short Spout Bellows Assembly Kit (Includes #2879 Clamp)	.3 (.14)
5803	V Short Spout Bellows Spring Assembly (Includes #2879 Clamp and Spring)	.1 (.05)
5901	V Long Spout Bellows Assembly (Includes #2879 Clamp)	.3 (.14)
5903	V Long Spout Bellows Spring Assembly (Includes #2879 Clamp and Spring)	.2 (.09)
6440	VLX Short Spout Assembly with <i>Streamshaper</i> [™]	.2 (.09)
6445	VLX Long Spout Assembly with <i>Streamshaper</i> [™]	.3 (.14)
580001	V Short Spout Assembly Kit (Includes #5801 Bellows Assembly, #580201 Spout Assembly and #5803 Spring Assembly)	.6 (.27)
580201	V Short Spout Assembly with <i>Streamshaper</i> [™]	.2 (.09)
590001	V Long Spout Assembly Kit (Includes #5901 Bellows Assembly, #590201 Spout Assembly, and #5903 Spring Assembly)	.7 (.32)
590201	V Long Spout Assembly W/ <i>Streamshaper</i> [™]	.3 (.14)

Balance Vapor Recovery Light Duty Diesel Spout Assemblies

580002	V Short Spout Assembly Kit (Includes #5801 Bellows Assembly, #580202 Spout Assembly and #5803 Spring Assembly)	.6 (.27)
580202	V Short Spout Assembly	.3 (.14)
590002	V Long Spout Assembly Kit (Includes #590202 Spout Assembly and #5903 Spring Assembly)	.8 (.36)
590202	V Long Spout Assembly	.3 (.14)





Husky

GENERAL FUELING PRODUCTS

V, V3, V34 Spouts

Spout assemblies.

Dimensions

Vacuum Assist Vapor Recovery

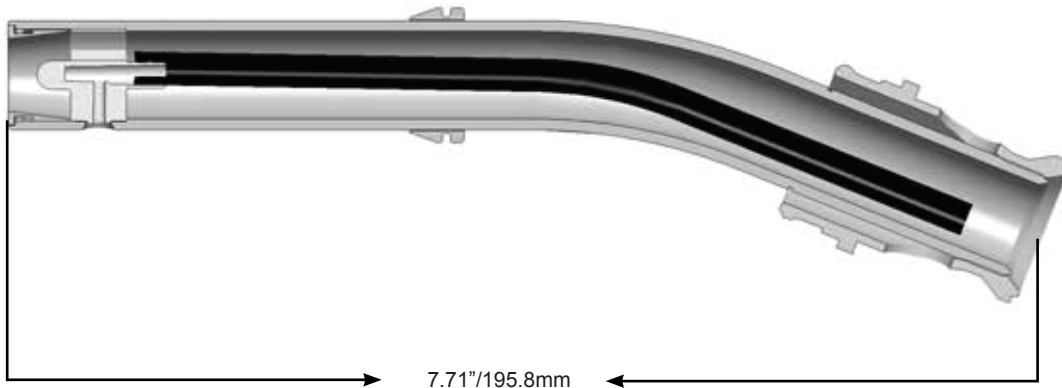

Balance Vapor Recovery

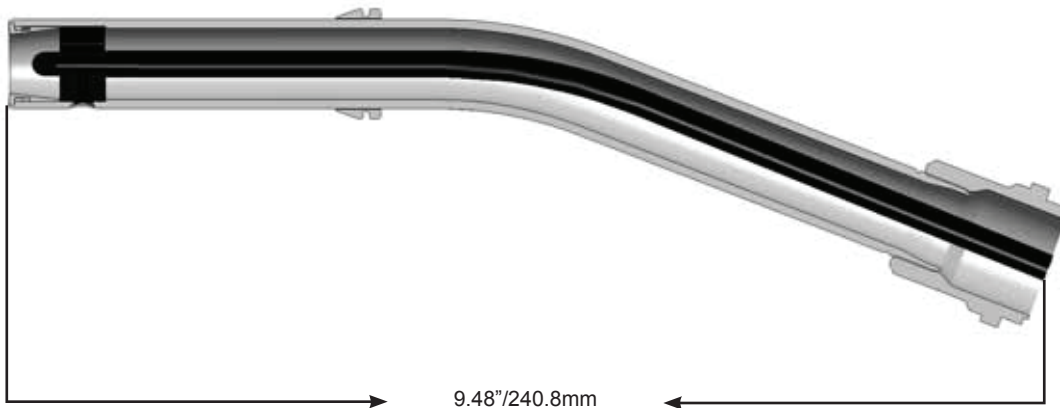
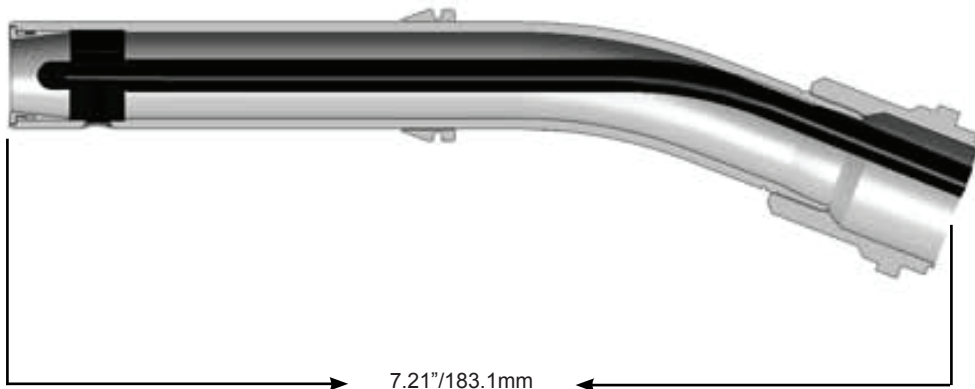

MADE IN THE U.S.A. 

Spout assemblies.

- Nickel plated aluminum spout.
- *Streamshaper*.™
- Stainless Steel Spout Bushing.
- E85 compatible.
- Keeps spout tip round.
- Reduces turbulence for straighter fuel flow and less splashback spillage.



Ethanol Spout Assemblies

MODEL NO.	DESCRIPTION	SHIPPING WEIGHT LBS (KG)
6207	X, XS E85 Spout Assembly with <i>Streamshaper</i> .™	.4 (.18)



Spout Assemblies.

Dimensions

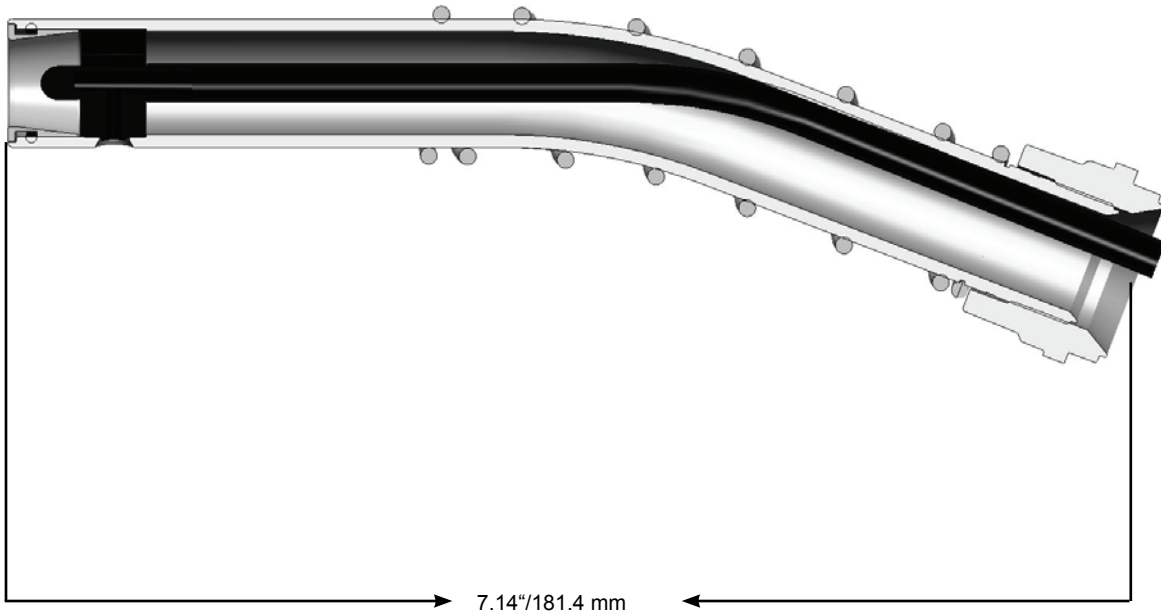



Husky

GENERAL FUELING PRODUCTS

Pressure/Vacuum Vents

Model 8060 has three (3) separate valves that address pressure/vacuum conditions in underground storage tanks (UST).

- Husky pressure / vacuum (P/V) vents incorporate three (3) separate valves to control over-pressure and vacuum conditions that arise in storage tanks. The three (3) valve system provides the necessary protection and durability needed in a UST vent cap.
- The vacuum valve is diaphragm operated and provides ten (10) times more sealing force than gravity devices. It constantly opens at 8" - 10" of water column (WC) / 2 - 2.5 KPa vacuum.
- The first over-pressure valve is diaphragm operated, giving ten (10) times more sealing force than gravity devices. It opens at 3" - 6" WC / .75 - 1.5 KPa pressure.
- The safety over-pressure valve is designed to handle high pressure / high flow conditions. This valve will vent up to 7900 SCFH at 2 psi / .14 bar.
- Threaded vent cap that is easily installed by using the cast-on hex nut which allows tightening without having to go between vent pipes.
- Not for use in California / EVR applications.

Pressure/Vacuum Vents

MODEL NO.	DESCRIPTION	SHIPPING WEIGHT LBS (KG)
8060	2" / 51 mm Thread-On Pressure / Vacuum Vent Cap	1.2 (.54)

Construction

Body	Aluminum
Screen	40 Mesh Stainless Steel
Set Screws	Stainless Steel
Deflector	Aluminum



This component was tested to and met the following criteria:

PRES. 3-6 IN. W.C.

VAC. 8-10 IN. W.C.

.05 CFH @ +2 IN. W.C.

.21 CFH @ -4 IN. W.C.





All Pressure/ Vacuum Vents have three (3) separate valves that address pressure/vacuum conditions in underground storage tanks.

Dimensions and System Options

Adapter

MODEL NO.	DESCRIPTION
5041	3 in / 76 mm Thread to 2 in / 51 mm Thread Pipe Adapter

Testing Equipment

MODEL NO.	DESCRIPTION
5426	Pressure / Vacuum Vent Test Adapter

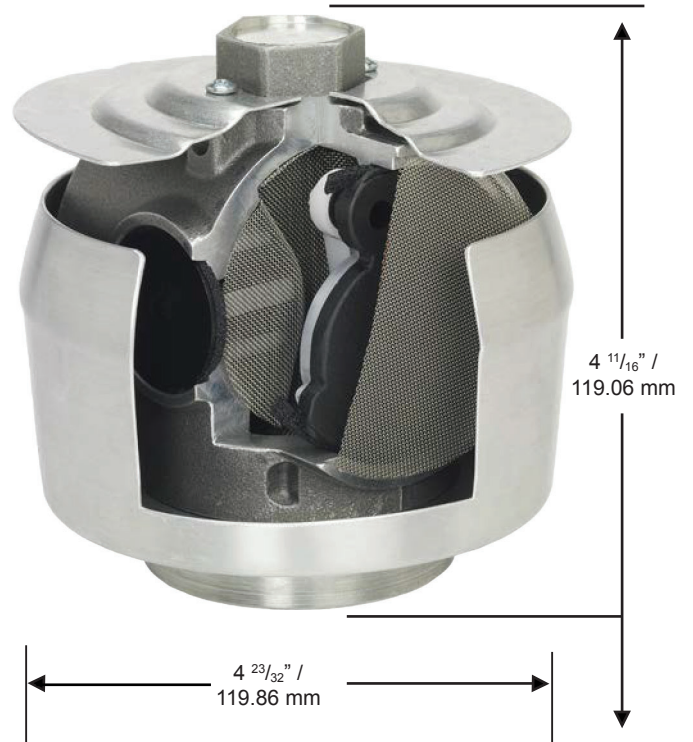

All Pressure/Vacuum Vents have three (3) separate valves that address pressure/vacuum conditions in underground storage tanks.

Model 4620 and 4885

- The three (3) valve system provides the necessary protection and durability needed in a UST vent cap.
- The vacuum valve is diaphragm operated and provides ten (10) times more sealing force than gravity devices. It consistently opens at 6" - 10" of water column (WC) / 1.5 - 2.5 KPa vacuum.
- The first over-pressure valve is diaphragm operated, giving ten (10) times more sealing force than gravity devices. It opens at 2.5" - 6" WC / .63 - 1.5 KPa pressure.
- Not for use in California / EVR applications.
- Model 4885 is certified to less than 1/3 of the CARB EVR Standard CP-201 which allows installation of three (3) P/V Vents maximum. This reduces installation time by not having to manifold the vent pipes together.
- Model 4885 is a threaded vent cap that is easily installed by using the caston hex nut which allows tightening without having to go between vent pipes.

- Model 4620 is a slip-on vent cap with a main pliable seal that seals to the vent stack and provides leakproof protection because the seal is at the end of the vent stack, not on the threads.
- Model 4620 uses four (4) stainless steel set screws to grip the vent stack preventing any loosening of the seal.

Model 5885

- Has an internal screen to protect the pressure plate in the event of a bad bulk drop.
- The safety over-pressure valve is designed to handle high pressure / high flow conditions. This valve will vent up to 7900 SCFH at 2 psi / .14 bar.
- Certified to less than 1/3 of the CARB EVR Standard CP-201 which allows installation of three (3) P/V vents maximum. This reduces installation time by not having to manifold the vent pipes together.
- Has a threaded vent cap that is easily installed by using the cast-on hex nut. This also allows tightening without having to go between vent pipes.

Pressure/Vacuum Vents

MODEL NO.	DESCRIPTION	SHIPPING WEIGHT LBS (KG)
4620	2 in / 51 mm Slip-On Pressure / Vacuum Vent Cap	1.2 (.54)
4885	2 in / 51 mm Thread-On Pressure / Vacuum Vent Cap	1.2 (.54)
5885	2 in / 51 mm Thread-On Pressure / Vacuum vent Cap with internal screen	1.2 (.54)

Construction

Body	Aluminum
Screen	40 Mesh Stainless Steel
Internal Screen	40 Mesh Stainless Steel (5885 only)
Set Screws	Stainless Steel
Deflector	Aluminum



This component was tested to and met the following criteria:

PRES. 2.5-6 IN. W.C.

VAC. 6-10 IN. W.C.

.05 CFH @ +2 IN. W.C.

.21 CFH @ -4 IN. W.C.



Texas Commission on Environmental Quality



California Environmental Protection Agency
AIR RESOURCES BOARD

All Pressure/Vacuum Vents have three (3) separate valves that address pressure/vacuum conditions in underground storage tanks.

Dimensions and System Options

Adapter

MODEL NO.	DESCRIPTION
5041	3 in / 76 mm Thread to 2 in / 51 mm Thread Pipe Adapter

Testing Equipment

MODEL NO.	DESCRIPTION
5426	Pressure / Vacuum Vent Test Adapter

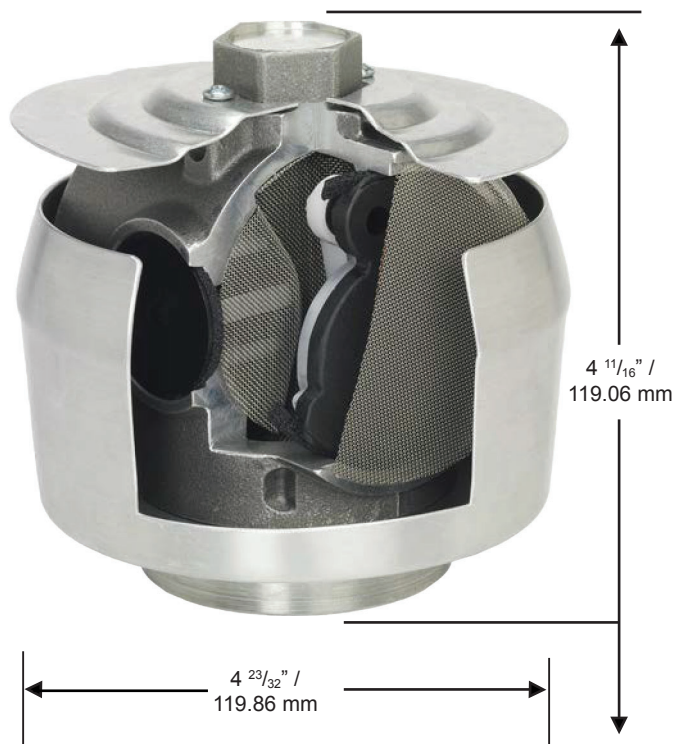



Husky

GENERAL FUELING PRODUCTS

Testing & Maintenance

Nozzle Service Kit



For Conventional, Balance or Vacuum Assist Systems.

- Nozzle Service Device (NSD) can be used with all brands / styles of retail nozzles.
- NSD provides easier removal and installation of nozzles - keeps nozzles off the ground.
- Safe-T-Break® Drain Cup can be used with all brands of breakaways - even non-reconnectable versions.
- Safe-T-Break® Drain Cup allows for pressure relief making reconnecting easier.
- Fuel Filter Cup can be used on all brands / styles of automotive and diesel dispenser fuel filters.
- Provides safe collection of fuel when replacing nozzles, Safe-T-Breaks® and fuel filters.
- Allows product maintenance without getting fuel directly on hands / skin.
- NSD, Safe-T-Break® Drain Cup, Fuel Filter Cup, wrench and pliers all fit inside the service pail for easy transportation.

Nozzle Service Kit

MODEL NO.	DESCRIPTION	SHIPPING WEIGHT LBS (KG)
7089	Nozzle Service Kit(includes part #6662 NSD, #7000 Safe-T-Break® Drain Cup, #7004, Fuel Filter Cup, #7086 Service Pail, #7088 NSD Pliers, #7332 Shear Valve Wrench and #7098 Fuel Filter Tool)	9.5 (4.3)

Basic Nozzle Service Kit

MODEL NO.	DESCRIPTION	SHIPPING WEIGHT LBS (KG)
7262	Basic Nozzle Service Kit (includes part #6662 NSD, #7000 Safe-T-Break® Drain Cup, #7004, Fuel Filter Cup and #7086 Service Pail)	9.0 (4.0)

Deluxe Nozzle Service Kit

MODEL NO.	DESCRIPTION	SHIPPING WEIGHT LBS (KG)
7263	Deluxe Nozzle Service Kit (includes part #6662 NSD, #7000 Safe-T-Break® Drain Cup, #7004, Fuel Filter Cup, #7086 Service Pail, #7332 Shear Valve Wrench, #7348 Deluxe Service Pliers and #7349 Deluxe Fuel Filter Pliers)	9.5 (4.3)

Construction

Service Pail	Steel
Nozzle Service Device (NSD)	Polypropylene
Safe-T-Break® Drain Cup	Polypropylene
Fuel Filter Cup	Plastisol



Part No. 7262



**Husky**

GENERAL FUELING PRODUCTS

Nozzle Service Kit

For Conventional, Balance, or Vacuum Assist Systems.

System Options

Nozzle Service Kit Parts

MODEL NO.	DESCRIPTION
6662	Nozzle Service Device (NSD)
7000	Safe-T-Break® Drain Cup
7004*	Fuel Filter Cup
7086	Service Pail
7088	NSD 12" Pliers
7098	Fuel Filter Tool (Wrench)
7099	Fuel Filter Service Kit (includes part #7004 Fuel Filter Cup and #7098 Fuel Filter Tool)
7332	Shear Valve Wrench
7348	Deluxe Service Pliers
7349	Deluxe Fuel Filter Pliers
7350	Deluxe Service Tool Kit (includes #7332 Shear Valve Wrench, #7348 Service Pliers, and #7349 Fuel Filter Pliers)
8071	Fuel Filter Cap with 5" Base

Color Chart

COLOR	SUFFIX	COLOR	SUFFIX
Blue	-01	White	-06
Red	-02	Gold	-08
Green	-03	Silver	-09
Black	-04	BP Green	-16
Yellow	-05	Pink	-20

*Safe-T-Breaks® and Safe-T-Break® Scuff Guards are to be ordered with the corresponding guard color option added to the model number.

Example: If BLUE guards are desired, add guard color option -01 to the model number (4034-01).

For custom colors, a minimum order of 4,000 guards will be required.



Part No. 7086



Part No. 7000



Part No. 7004



Part No. 6662



MADE IN THE U.S.A.





Husky

GENERAL FUELING PRODUCTS

Flo-Equalizers™

FLO-Equalizer™



Husky Flo-Equalizers™ limit fuel flow to a maximum 10 gpm / 37.8 Lpm to comply with Federal Register Vol. 58, No. 55, page 16109.

- All Husky Flo-Equalizers™ are pressure compensating and allow full advantage of high capacity pumps.
- Low pressure loss at flows less than 10 gpm / 37.8 Lpm.

Model 4490

- For conventional systems.
- Installs in-line within the fuel line.
- Comes standard with pipe nipple for easy installation.



Model 4490

Model 5827

- For balance vapor recovery systems.
- Installs directly into the dispenser outlet casting.

Model 5837

- For vacuum assist vapor recovery systems.
- Installs directly into the dispenser outlet casting.

Model 7490

- For conventional nozzles with 3/4" / 19 mm inlet.
- Installs into nozzle inlet.



Model 7490



Model 5827

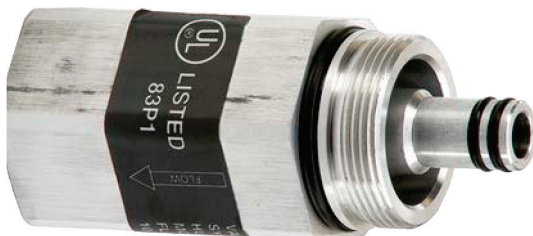

Model 5837

Flo-Equalizer™

MODEL NO.	DESCRIPTION	SHIPPING WEIGHT LBS (KG)
4490	3/4" F x 3/4" F NPTF Threads	.37 (0.16)
5827	1 1/8" x 12 Threads	.43 (0.19)
5837	M34 x 1.5 Threads	.37 (0.16)
7490	Internal use only	.02 (0.01)

Construction

Body	4490, 5827 & 5837: Aluminum 7490: Plastic
Seals	4490 & 7490: N/A 5827 & 5837: Fluorocarbon





FLO-Equalizer™

Husky Flo-Equalizers™ limit fuel flow to a maximum 10 gpm / 37.8 Lpm to comply with Federal Register Vol. 58, No. 55, page 16109.

Dimensions

FLO-EQUALIZERS™

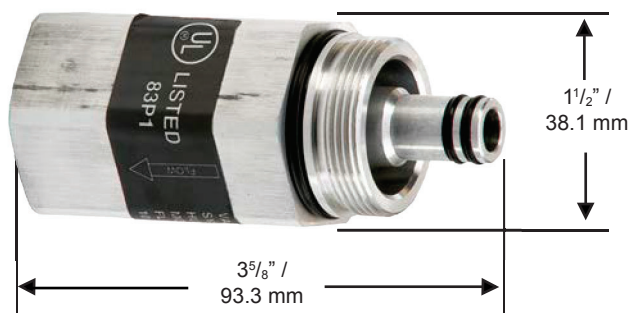
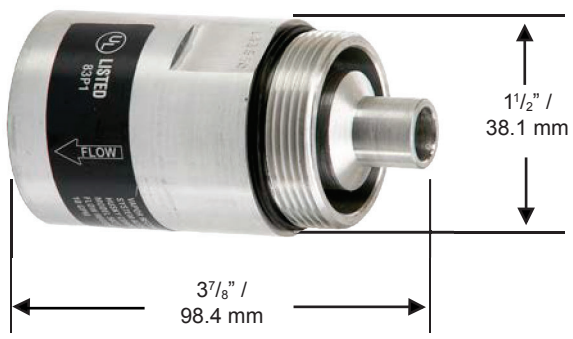

MADE IN THE U.S.A.



Husky

GENERAL FUELING PRODUCTS

DEF Adaptors

Diesel Exhaust Fueling Adaptors.

- DEF adaptors have stainless steel construction.



Diesel Exhaust Adaptors

MODEL NO.	DESCRIPTION	SHIPPING WEIGHT LBS (KG)
7214	Hose Barb 3/4" ID Hose x 3/4" BSPP with Seal Kit	.22 (.10)
7285	1"M x 1"M BSPP Straight Adaptor	.29 (.13)
7356	1"M BSPP x M M34 Straight Adaptor	.30 (.13)
8413	Hose Barb 3/4" ID Hose x 1" BSPP with Seal Kit	.29 (.13)
10227	1" F BSPP Adaptor	.20 (.10)
10549	1" F BSP x 1" NPT Adaptor	.20 (.10)
10551	1" F BSP x 3/4" NPT Adaptor	.20 (.10)
10553	1" F BSP x 3/4" BSP Adaptor	.20 (.10)
10579	1" F BSP x 3/4" Hose Barb Adaptor	.20 (.10)
10675	1" F x 1" F BSPP Straight Adaptor	.20 (.10)

Diesel Exhaust Fueling Adaptors.

Dimensions

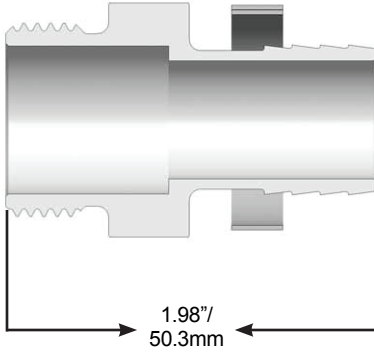



Husky

GENERAL FUELING PRODUCTS

Hoses

Premium Hardwall Gasoline Pump Hose.

- Recommended anywhere a hardwall hose is required.
- Recommended for all gasohol blends, diesel, leaded, unleaded gasoline, E15 Ethanol and B-20 Biodiesel.
- Designed for durability, flexibility, and easy handling.
- Highly resistant to cuts, abrasions, sun and weather.
- Resists kinking and eliminates meter creep.
- Improves ozone and abrasion resistance while providing increased life.
- Improves draping and handling characteristics.
- Will not mark or scratch vehicle finishes.
- Hose material is private branded and UL Listed to UL 330 and CAN/ULC-S612-99.
- All curb pump hose assemblies are 100% pressure tested, inspected for electrical continuity and sample pull tested.



Hardwall Hoses

MODEL NO.	DESCRIPTION	SHIPPING WEIGHT LBS (KG)
5/8" HOSES		
CP10HW01	5/8" Hardwall 1' Assembly Hose	0.39 (0.58)
CP10HW09	5/8" Hardwall 9' Assembly Hose	3.5 (1.6)
3/4" HOSES		
CP12HWG08	3/4" Green Hardwall 8' Assembly Hose	3.8 (1.7)
CP12HWG09	3/4" Green Hardwall 9' Assembly Hose	4.2 (1.9)
CP12HWG09SV	3/4" Green Hardwall 9' Assembly Hose Swivel	4.2 (1.9)
CP12HWG10	3/4" Green Hardwall 10' Assembly Hose	4.7 (2.1)
CP12HWG12SV	3/4" Green Hardwall 12' Assembly Hose Swivel	5.6 (2.5)
CP12HWR10	3/4" Red Hardwall 10' Assembly Hose	4.7 (2.1)
CP12HW09	3/4" Hardwall 9' Assembly Hose	4.2 (1.9)
CP12HW09.5	3/4" Hardwall 9.5' Assembly Hose	4.5 (2.0)
CP12HW09SV	3/4" Hardwall 9' Assembly Hose Swivel	4.2 (1.9)
CP12HW12	3/4" Hardwall 12' Assembly Hose	5.6 (2.5)
CP12HW14	3/4" Hardwall 14' Assembly Hose	6.6 (3.0)
CP12HW14X	3/4" Hardwall 14' Assembly Hose Bulk	6.6 (3.0)
CP12HW15X	3/4" Hardwall 14' Assembly Hose Bulk	6.6 (3.0)
CP12HW17	3/4" Hardwall 17' Assembly Hose	8.0 (3.6)
CP12HW9.5X	3/4" Hardwall 9.5' Assembly Hose Bulk	4.5 (2.0)
1" HOSES		
CP16HW01	1" Hardwall 1' Assembly Hose	0.64 (0.95)
CP16HW06	1" Hardwall 6' Assembly Hose	3.8 (1.7)
CP16HW10	1" Hardwall 10' Assembly Hose	6.4 (2.9)
CP16HW10X	1" Hardwall 10' Assembly Hose Bulk	6.4 (2.9)
CP16HW15	1" Hardwall 15' Assembly Hose	9.6 (4.4)
CP16HW15X	1" Hardwall 15' Assembly Hose Bulk	9.6 (4.4)
CP16HW17	1" Hardwall 17' Assembly Hose	10.9 (4.9)
CP16HW20X	1" Hardwall 20' Assembly Hose Bulk	12.8 (5.8)

Construction

Tube	Black Nitrile
Cover	Black HYPALON, wrap impression
Reinforcement	Multiple textile braids with dual static wire helix
Temperature Range	-40°F to +180°F (-40°C to +82°C)
Body	3/4" Red or Green Hardwall Available



All are UL listed except with Swivels



EagleFlex® Hardwall

Premium Hardwall Gasoline Pump Hose.

System Options

Available in these Sizes

ID		NOM OD		MAX WP		WEIGHT	
Size	MM	IN	MM	PSI	MPA	LB/FT	KG/M
5/8"	16	1.03	26	150	1.03	0.39	0.58
3/4"	19	1.17	30	150	1.03	0.47	0.70
1"	25	1.45	37	150	1.03	0.64	0.95

Couplings

Permanent internally expanded fixed.

Reattachable fixed and Reattachable swivel 3/4" and 1" male NPT. UL does not recognize field installation of reattachable fittings.



MADE IN THE U.S.A. 

Softwall Gasoline Pump Hose.

- A lightweight, flexible hose for use when a hardwall hose is inappropriate.
- Recommended for all gasohol blends, diesel, leaded, unleaded gasoline, E15 Ethanol and B-20 Biodiesel.
- Excellent strength without sacrificing flexibility.
- Highly resistant to cuts, abrasions, sun and weather.
- HYPALON cover will not mark or scratch vehicle finishes.
- All curb pump hose assemblies are 100% pressure tested, inspected for electrical continuity and sample pull tested.



Softwall Hoses

MODEL NO.	DESCRIPTION	SHIPPING WEIGHT LBS (KG)
3/4" HOSES		
CP12SW04X	3/4" Softwall 4' Assembly Hose Bulk	1.4 (0.6)
CP12SW09	3/4" Softwall 9' Assembly Hose	3.1 (1.4)
CP12SW10	3/4" Softwall 10' Assembly Hose	3.4 (1.5)
CP12SW10X	3/4" Softwall 10' Assembly Hose Bulk	3.4 (1.5)
CP12SW12	3/4" Softwall 12' Assembly Hose	4.1 (1.9)
CP12SW14	3/4" Softwall 14' Assembly Hose	4.8 (2.2)
CP12SW14X	3/4" Softwall 14' Assembly Hose Bulk	4.8 (2.2)
CP12SW17	3/4" Softwall 17' Assembly Hose	5.8 (2.6)
CP12SW20	3/4" Softwall 20' Assembly Hose	6.8 (3.1)
CP12SW30	3/4" Softwall 30' Assembly Hose	10.2 (4.6)
CP12SW40	3/4" Softwall 40' Assembly Hose	13.6 (6.2)
CP12SW50	3/4" Softwall 50' Assembly Hose	17.0 (7.7)
CP12SW9.5	3/4" Softwall 9.5' Assembly Hose	3.2 (1.5)
1" HOSES		
CP16SW10	1" Softwall 10' Assembly Hose	4.7 (2.1)
CP16SW11	1" Softwall 11' Assembly Hose	5.2 (2.4)
CP16SW12	1" Softwall 12' Assembly Hose	5.6 (2.5)
CP16SW14	1" Softwall 14' Assembly Hose	6.6 (3.0)
CP16SW14X	1" Softwall 14' Assembly Hose Bulk	6.6 (3.0)
CP16SW17	1" Softwall 17' Assembly Hose	8.0 (3.6)
CP16SW20	1" Softwall 20' Assembly Hose	9.4 (4.3)
CP16SW20X	1" Softwall 20' Assembly Hose Bulk	9.4 (4.3)
CP16SW60	1" Softwall 60' Assembly Hose	28.2 (12.8)

Construction

Tube	Black Nitrile
Cover	Black HYPALON
Reinforcement	Multiple textile braids static wire
Temperature Range	-40° F to +180° F (-40° C to +82° C)





Softwall Gasoline Pump Hose.

System Options

Available in these Sizes

Size	ID		NOM OD		MAX WP		WEIGHT	
	MM	IN	MM	IN	PSI	MPA	LB/FT	KG/M
3/4"	19	1.10	28	1.10	150	1.03	0.34	0.51
1"	25	1.39	35	1.39	150	1.03	0.47	0.63

Couplings

Permanent internally expanded fixed 3/4" and 1" male NPT.

Swivel couplings are not available with softwall hose.



Wirebraid Gasoline Pump Hose.

- Recommended anywhere a hardwall or softwall hose is inappropriate.
- Recommended for all gasohol blends, diesel, leaded, unleaded gasoline, E15 Ethanol and B-20 Biodiesel.
- Provides full flow with no internal spring guards and will withstand full suction.
- Resistant to crushing and stands up to run-over.
- Highly resistant to cuts, abrasions, sun and weather.
- Flexibility of a softwall, durability of a hardwall.
- Assures accurate readings at the pump.
- Will not mark or scratch vehicle finishes.
- Hose material is private branded and UL Listed to UL 330 and CAN/ULC-S612-99.
- All curb pump hose assemblies are 100% pressure tested, inspected for electrical continuity and sample pull tested.



Wirebraid Hoses

MODEL NO.	DESCRIPTION	SHIPPING WEIGHT LBS (KG)
5/8" HOSES		
CP10WB08	5/8" Wirebraid 8' Assembly Hose	2.8 (1.3)
CP10WB09	5/8" Wirebraid 9' Assembly Hose	0.26 (0.12)
CP10WB09.5	5/8" Wirebraid 9.5' Assembly Hose	3.3 (1.5)
CP10WB10	5/8" Wirebraid 10' Assembly Hose	3.5 (1.6)
CP10WB14	5/8" Wirebraid 14' Assembly Hose	4.9 (2.2)
CP10WB9.5X	5/8" Wirebraid 9.5' Assembly Hose Bulk	3.3 (1.5)
3/4" HOSES		
CP12WB04	3/4" Wirebraid 4' Assembly Hose	1.7 (0.8)
CP12WB05	3/4" Wirebraid 5' Assembly Hose	2.1 (1.0)
CP12WB06	3/4" Wirebraid 6' Assembly Hose	2.5 (1.1)
CP12WB08	3/4" Wirebraid 8' Assembly Hose	3.4 (1.5)
CP12WB09	3/4" Wirebraid 9' Assembly Hose	3.8 (1.7)
CP12WB09SV	3/4" Wirebraid 9' Assembly Hose Swivel	3.8 (1.7)
CP12WB10	3/4" Wirebraid 10' Assembly Hose	4.2 (1.9)
CP12WB10X	3/4" Wirebraid 10' Assembly Hose Bulk	4.2 (1.9)
CP12WB12	3/4" Wirebraid 12' Assembly Hose	5.0 (2.3)
CP12WB12SV	3/4" Wirebraid 12' Assembly Hose Swivel	5.0 (2.3)
CP12WB12X	3/4" Wirebraid 12' Assembly Hose Bulk	5.0 (2.3)
CP12WB14	3/4" Wirebraid 14' Assembly Hose	5.9 (2.7)
CP12WB15SV	3/4" Wirebraid 15' Assembly Hose Swivel	6.3 (2.9)
CP12WB16	3/4" Wirebraid 16' Assembly Hose	6.7 (3.0)
CP12WB20	3/4" Wirebraid 20' Assembly Hose	8.4 (3.8)
CP12WB50X	3/4" Wirebraid 50' Assembly Hose Bulk	21.0 (9.5)
1" HOSES		
CP16WB04	1" Wirebraid 4' Assembly Hose	2.0 (0.9)
CP16WB06	1" Wirebraid 6' Assembly Hose	3.0 (1.4)
CP16WB08	1" Wirebraid 8' Assembly Hose	4.0 (1.8)
CP16WB09	1" Wirebraid 9' Assembly Hose	4.5 (2.0)
CP16WB10	1" Wirebraid 10' Assembly Hose Bulk	5.0 (2.3)
CP16WB10X	1" Wirebraid 10' Assembly Hose	5.0 (2.3)
CP16WB100SV	1" Wirebraid 100' Assembly Hose Swivel	50.0 (22.7)
CP16WB100SVSV	1" Wirebraid 100' Assembly Hose w/ Swivel on both ends	50.0 (22.7)
CP16WB12	1" Wirebraid 12' Assembly Hose	6.0 (2.7)
CP16WB12SV	1" Wirebraid 12' Assembly Hose Swivel	6.0 (2.7)
CP16WB13	1" Wirebraid 13' Assembly Hose	6.5 (3.0)
CP16WB14	1" Wirebraid 14' Assembly Hose	7.0 (3.2)
CP16WB14X	1" Wirebraid 14' Assembly Hose Bulk	7.0 (3.2)
CP16WB16	1" Wirebraid 16' Assembly Hose	8.0 (3.6)
CP16WB18	1" Wirebraid 18' Assembly Hose	9.0 (4.1)
CP16WB18X	1" Wirebraid 18' Assembly Hose Bulk	9.0 (4.1)
CP16WB20	1" Wirebraid 20' Assembly Hose	10.0 (4.5)
CP16WB20X	1" Wirebraid 20' Assembly Hose Bulk	10.0 (4.5)
CP16WB30	1" Wirebraid 30' Assembly Hose	15.0 (6.8)
CP16WB50SV	1" Wirebraid 50' Assembly Hose Swivel	25.0 (11.3)

Construction

Tube	Black Nitrile
Cover	Black HYPALON, wrap impression
Reinforcement	Multiple textile braids with dual static wire helix
Temperature Range	-40° F to +180° F (-40° C to +82° C)



All are UL listed
except with Swivels

**Husky**

GENERAL FUELING PRODUCTS

EagleFlex® Wirebraid**Wirebraid Gasoline Pump Hose.****System Options****Available in these Sizes**

ID		NOM OD		MAX WP		WEIGHT	
Size	MM	IN	MM	PSI	MPA	LB/FT	KG/M
5/8"	16	0.97	25	150	1.03	0.35	0.52
3/4"	19	1.10	28	150	1.03	0.42	0.63
1"	25	1.34	34	150	1.03	0.50	0.74

Couplings

Permanent internally expanded fixed.

Reattachable fixed and Reattachable swivel 3/4" and 1" male NPT. UL does not recognize field installation of reattachable fittings.



MADE IN THE U.S.A.



Gasoline Hose Assemblies with Static Wire.

- Designed for durability and flexibility.
- Oil and abrasion resistant.
- Supplied with static wire.
- Recommended for use with electric pumps.
- Static wire hose always recommended with electric motors.
- Designed for use in agricultural, industrial and construction maintenance applications.
- Engineered for dispensing gasoline, kerosene and oil from farm and barrel-type pumps where UL approval is not required.
- Curb pump hose recommended for:
 - UL Listed hose material requirements.
 - For high aromatics or severe applications.
- All Farm Tank hose assemblies are 100% inspected for electrical continuity.
- Do not use these hoses at a service station or to refuel aircraft.

Farm Fueling Hoses

MODEL NO.	DESCRIPTION	SHIPPING WEIGHT LBS (KG)
3/4" HOSES		
FT012S10	3/4" x 10' Farm Tank Assembly Hose Bulk	2.9 (1.3)
FT012S12	3/4" x 12' Farm Tank Assembly Hose Bulk	3.5 (1.6)
FT012S12B	3/4" x 12' Farm Tank Assembly Hose Boxed	3.5 (1.6)
FT012S14	3/4" x 14' Farm Tank Assembly Hose Bulk	4.1 (1.9)
FT012S14B	3/4" x 14' Farm Tank Assembly Hose Boxed	4.1 (1.9)
FT012S15	3/4" x 15' Farm Tank Assembly Hose Bulk	4.4 (2.0)
FT012S15B	3/4" x 15' Farm Tank Assembly Hose Boxed	4.4 (2.0)
FT012S17	3/4" x 17' Farm Tank Assembly Hose Bulk	4.9 (2.2)
FT012S20	3/4" x 20' Farm Tank Assembly Hose Bulk	5.8 (2.6)
FT012S20B	3/4" x 20' Farm Tank Assembly Hose Boxed	5.8 (2.6)
1" HOSES		
FT016S10	1" x 10' Farm Tank Assembly Hose Bulk	4.5 (2.0)
FT016S12	1" x 12' Farm Tank Assembly Hose Bulk	5.4 (2.4)
FT016S12B	1" x 12' Farm Tank Assembly Hose Boxed	5.4 (2.4)
FT016S14	1" x 14' Farm Tank Assembly Hose Bulk	6.3 (2.9)
FT016S15	1" x 15' Farm Tank Assembly Hose Bulk	6.8 (3.1)
FT016S15B	1" x 15' Farm Tank Assembly Hose Boxed	6.8 (3.1)
FT016S17	1" x 17' Farm Tank Assembly Hose Bulk	7.7 (3.5)
FT016S20	1" x 20' Farm Tank Assembly Hose Bulk	9.0 (4.1)
FT016S20B	1" x 20' Farm Tank Assembly Hose Boxed	9.0 (4.1)
FT016S25	1" x 25' Farm Tank Assembly Hose Bulk	11.3 (5.1)

Construction

Tube	NBR, RMA Class A
Cover	NBR/PVC RMA Class A
Reinforcement	Spiral high tensile strength polyester cord
Temperature Range	-20° F to +160° F (-29° C to +71° C)





Premier Farm Tank

Gasoline Hose Assemblies with Static Wire.

System Options

Available in these Sizes

Size	ID		NOM OD		MAX WP		WEIGHT	
	MM	IN	MM	IN	PSI	MPA	LB/FT	KG/M
3/4"	19	1.13	29	1.14	60	.41	0.29	0.43
1"	25	1.38	35	1.38	60	.41	0.45	0.67

Couplings

Permanent externally crimped 3/4" and 1" NPT.



MADE IN THE U.S.A. 

Whip Hoses

MODEL NO.	DESCRIPTION	SHIPPING WEIGHT LBS (KG)
5/8" HOSES		
CP10HW.75	5/8" Hardwall 9" Assembly Hose	0.3 (0.4)
3/4" HOSES		
CP12HW.75	3/4" Hardwall 9" Assembly Hose	0.3 (0.5)
CP12HWG.75	3/4" Green Hardwall 9" Assembly Hose	0.3 (0.5)
1" HOSES		
CP16HW.75	1" Hardwall 9" Assembly Hose	0.5 (0.7)





Whip Hoses



MADE IN THE U.S.A. 



Husky

GENERAL FUELING PRODUCTS

EZ-Connect

The only certified, pre-assembled, pressure and continuity-tested hanging hardware.

- Stage II Decommissioning Ready!
- Can also be configured for new station installs.
- Fully customizable.
- Available in 5/8" and 3/4" assemblies.
- Pre-fabricated hanging hardware assembly.
- Includes choice of Hose/Dispenser adaptor (Balanced/Vac-Assist/Heavy).
- Robust multi-plane Husky swivel.
- 3 types of hose material offered: Hardwall, Wirebraid and Softwall.
- Chrome-plated brass fittings.
- UL listed hose assembly.
- Your choice of nozzle configuration.
- 100% continuity/pressure tested.
- Thread sealant used on all component connections (Gasoila®).
- All required hanging hardware for decommissioning in one single package.





The only certified, pre-assembled, pressure and continuity-tested hanging hardware.

Thousands of conventional fuel pump combinations are available with **EZ-Connect's** six interchangeable components, making it possible to design a pump package to meet specific fuel-dispensing needs.

This sample chart, using 5/8" Hardwall Hoses, demonstrates the many options available:

5/8" Connections/9' Hardwall Hoses Kits			
	w/2273 (Single Use) STB	w/3360 Reconnect STB	w/8330 MagBreak™
Balance to Conventional Adaptor	6959	6959	6959
5/8" x 9" Hardwall Whip Hose	CP10HW.75	CP10HW.75	CP10HW.75
Safe-T-Break®	2273	3360	8330
5/8" x 9' Hardwall Curb Hose	CP10HW09	CP10HW09	CP10HW09
3/4" Multi-Plane Swivel	0350	0350	0350
New XS Pressure Activated Automatic Nozzle w/1808 Splash Guard	159559	159559	159559
5/8" Connections/10' Hardwall Hoses Kits			
	w/2273 (Single Use) STB	w/3360 Reconnect STB	w/8330 MagBreak™
Balance to Conventional Adaptor	6959	6959	6959
5/8" x 9" Hardwall Whip Hose	CP10HW.75	CP10HW.75	CP10HW.75
Safe-T-Break®	2273	3360	8330
5/8" x 10' Hardwall Curb Hose	CP10HW10	CP10HW10	CP10HW10
3/4" Multi-Plane Swivel	0350	0350	0350
New XS Pressure Activated Automatic Nozzle w/1808 Splash Guard	159559	159559	159559



MADE IN THE U.S.A. 